

# SECULIFE ST PRO

## Instrument for Testing the Electrical Safety of Electrical (Medical) Devices

3-447-032-03  
1/7.19



## Controls

**Display of symbols for devices connected to the USB master interface (see below)**

- For keyboard \*
- For barcode/RFID scanner \*
- For printer
- For USB flash drive

**Bluetooth®** \*\* (M01), see parameters on page 108

Probe Type	Applications
Strain relief, <b>black</b>	Test current: 200 mA / 10 A, max. 16 A
SK2-25A (Z746C) Strain relief, <b>green</b>	Test current: 200 mA / 25 A, max. 25 A

**Fixed Function Keys**

**PRINT:** print via USB

**ESC:** back

**HELP:** help images

**MEM:** database

**START:** start/stop  
– Single test  
– Sequence

**Finger contact**

**Symbols:**

– Measurement at IT system active

– Offset for RPE active

– For the devices connected to the USB master port, see above

**Rotary Selector Switch**

**Sequences A1 ... A9 (automatic test sequences)**  
*Rotary switch level: orange*

**Test socket for DUTs**  
**Caution!** Depending on the measuring task, the test probe may be charged with line voltage.

**Single measurements**  
*Rotary switch level: green*

**Mains to test socket**  
SFC: Normal status

**Mains to test socket**  
SFC: N interrupted

- \* The receiver must be plugged in here for wireless entry devices.
- \*\* Only displayed in case of active connection to another **Bluetooth®** device

## Order Features

M7050-	None	With
Touchscreen	—	E01
10 A RPE test current	—	G01
25 A RPE test current	—	G02
2 <sup>nd</sup> Test probe	—	H01
Voltage measuring input *	—	I01
Applied part sockets	—	J01
Test sequence per IEC 60601	KA00	KA01
Z853R – SECUTEST DB+	—	KB01
IZYTRONIQ Business Starter	—	KC01
Z853S – SECUTEST DB COMFORT	—	KD01
Bluetooth®	M00	M01

\* For voltage measurement, for connecting a current clamp sensor or an AT3 adapter, and for temperature measurement via RTD

Connections

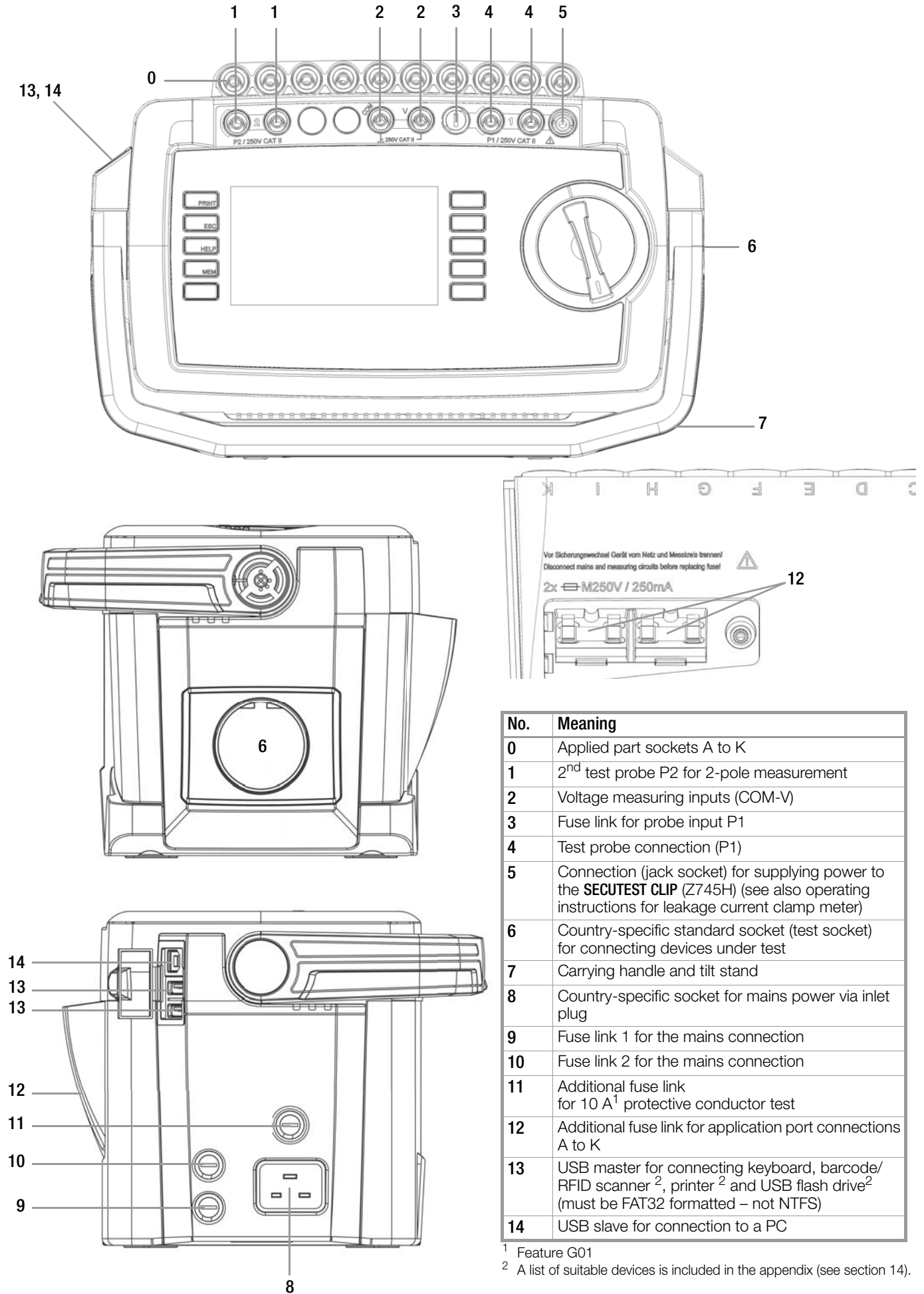

No.	Meaning
0	Applied part sockets A to K
1	2 <sup>nd</sup> test probe P2 for 2-pole measurement
2	Voltage measuring inputs (COM-V)
3	Fuse link for probe input P1
4	Test probe connection (P1)
5	Connection (jack socket) for supplying power to the <b>SECUTEST CLIP</b> (Z745H) (see also operating instructions for leakage current clamp meter)
6	Country-specific standard socket (test socket) for connecting devices under test
7	Carrying handle and tilt stand
8	Country-specific socket for mains power via inlet plug
9	Fuse link 1 for the mains connection
10	Fuse link 2 for the mains connection
11	Additional fuse link for 10 A <sup>1</sup> protective conductor test
12	Additional fuse link for application port connections A to K
13	USB master for connecting keyboard <sup>2</sup> , printer <sup>2</sup> and USB flash drive <sup>2</sup> (must be FAT32 formatted – not NTFS)
14	USB slave for connection to a PC

<sup>1</sup> Feature G01

<sup>2</sup> A list of suitable devices is included in the appendix (see section 14).

These operating instructions describe an instrument with software version FW3.0.0.

## Overview of the Test Instrument's Scope of Functions

Switch Position	Measuring Functions Test Current/Voltage	Measurement Type, Connection Type
<b>Single measurements, rotary switch level: green</b>		
section 8.5	<b>R<sub>PE</sub></b> R <sub>PE</sub> <b>Protective conductor resistance</b> I <sub>p</sub> 200 mA test current 10 A test current <sup>1</sup> (feature G01) 25 A test current <sup>1</sup> (feature G02)	PE(TS) - P1 passive PE(TS) - P1 (TS on) PE(mains) - P1 <sup>6</sup> PE(mains) - P1 clamp <sup>2, 6</sup> P1-P2 <sup>3</sup>
	<b>R<sub>INS</sub></b> R <sub>INS</sub> <b>Insulation resistance (PC I/PC II)</b> U <sub>INS</sub> Test voltage	LN(TS) - PE(TS) LN(TS) - P1 P1-P2 <sup>3</sup> PE(mains) - P1 PE(TS) - P1 LN(TS) - P1//PE(TS) LN(TS) - APP PE(mains) - APP PE(TS) - APP P1//PE(TS) - APP P2 - APP
section 8.7.1	<b>I<sub>PE</sub></b> I <sub>PE</sub> <b>Protective conductor current, RMS</b>	Direct
	I <sub>PE-</sub> AC component	Differential
	I <sub>PE=</sub> DC component	Alternative
	U <sub>LPE</sub> Test voltage	AT3-Adapter <sup>2</sup>
	U <sub>Gen</sub> Reference voltage (alternative)	Clamp <sup>2</sup>
section 8.7.2	<b>I<sub>T</sub></b> I <sub>T</sub> <b>Touch current, TRMS</b>	Direct P1
	I <sub>T-</sub> AC component	Differential P1
	I <sub>T=</sub> DC component	Alternative P1
	U <sub>LPE</sub> Test voltage	Perm. conn. P1
	U <sub>Gen</sub> Reference voltage (alternative)	Alternative P1-P2
section 8.7.3	<b>I<sub>E</sub></b> I <sub>E</sub> <b>Device leakage current, TRMS</b>	Direct
	I <sub>E-</sub> AC component	Differential
	I <sub>E=</sub> DC component	Alternative
	U <sub>LPE</sub> Test voltage	AT3-Adapter <sup>2</sup>
	U <sub>Gen</sub> Reference voltage (alternative)	Clamp <sup>2</sup>
section 8.7.4	<b>I<sub>A</sub></b> I <sub>A</sub> <b>Leakage current from the applied part TRMS</b>	Direct P1
	U <sub>LPE</sub> Test voltage	Direct APP
	U <sub>Gen</sub> Voltage at application part	Alternative P1
		Alternative APP Perm. conn. P1 Perm. conn. APP APP - P2 <sup>7</sup>
section 8.7.5	<b>I<sub>P</sub></b> I <sub>P</sub> <b>Patient leakage current, TRMS</b>	Direct P1
	I <sub>P-</sub> AC component	Direct APP
	I <sub>P=</sub> DC component	Perm. conn. P1
	U <sub>LPE</sub> Test voltage	Perm. conn. APP
section 8.7.6	<b>I<sub>PA</sub></b> I <sub>PA</sub> <b>Patient auxiliary current, TRMS</b>	Direct APP
	I <sub>PA-</sub> AC component	Perm. conn. APP
	I <sub>PA=</sub> DC component	
	U <sub>LPE</sub> Test voltage	
section 8.9	<b>U</b> U <b>Probe voltage, RMS</b>	PE-P1
	U <sub>-</sub> Alternating voltage component	PE-P1 (TS on *)
	U <sub>=</sub> Direct voltage component	* Polarity parameter
	<b>U</b> U <b>Measuring voltage, RMS <sup>2</sup></b>	
	U <sub>-</sub> Alternating voltage component <sup>2</sup>	V - COM
	U <sub>=</sub> Direct voltage component <sup>2</sup>	V - COM (TS on)
section 8.10	<b>P</b> P <b>Function test at the test socket</b>	
	I Current between L and N	
	U Voltage between L and N	
	f Frequency	Polarity parameter
	P Active power	
	S Apparent power	
	PF Power factor	
<b>Probe measuring functions</b>		
section 8.11	<b>EL1</b> Function test for extension cords with adapter: continuity, short-circuit, polarity (wire reversal <sup>5</sup> )	EL1 adapter AT3-IIIIE adapter VL2E adapter
section 9	<b>EXTRA</b> Reserved for expansion within the framework of software updates	
	t <sub>A</sub> <sup>4</sup> PRCD time to trip for 10/30 mA PRCDs	
	°C Temperature measurement <sup>2</sup> with Pt100/Pt1000	V - COM
	I <sub>Z</sub> Current clamp measurement <sup>2</sup> with current clamp sensor	V - COM

- 10/25 A R<sub>PE</sub> measurements are only possible with line voltages of 115/230 V and line frequencies of 50/60 Hz.
- Voltage measuring inputs
- Connection for 2<sup>nd</sup> test probe P2 for 2-pole measurement
- Measurement of time to trip isn't possible in IT systems.
- No checking for reversed polarity takes place when the EL1 adapter is used.
- Connection type not available with feature G02
- For ME equipment (**m**edical **e**lectrical equipment) with own power supply

### Key

- APP = application part  
 Alternative = alternative measurement (equivalent leakage current measurement)  
 Differential = differential current measurement  
 Direct = direct measurement  
 LN(TS) = short-circuited conductors L and N at test socket  
 P1 = measurement with test probe P1  
 P1-P2 = 2-pole measurement with test probes P1 and P2  
 PE-P1 = measurement between PE and test probe P1  
 PE(TS) = protective conductor at the test socket  
 PE(mains) = protective conductor at the mains connection

Switch Position	Standard	Measurement Type, Connection Type
<b>Automatic test sequences, rotary switch level: orange</b>		
<b>Preconfigured (freely adjustable) test sequences – default settings</b>		
<b>A1</b>	<b>IEC 62353</b>	Passive, test socket, 1 group BF APPs A-K, PCI
<b>A2</b>	<b>IEC 62353</b>	Passive, test socket, 1 group BF APPs A-K, PCII
<b>A3</b>	<b>IEC 62353</b>	Passive, tests on, 1 group BF APPs A-K, PCI + II
<b>A4</b>	<b>IEC 62353</b>	Active, automatic detection, 1 group BF APPs A-K, PCI
<b>A5</b>	<b>IEC 62353</b>	Active, automatic detection, 1 group BF APPs A-K, PCII
<b>A6</b>	<b>IEC 62353</b>	Active, automatic detection, 1 group BF APPs A-K, PCI + II
<b>With feature D02</b>		
<b>A7</b>	<b>VDE 0701-0702 ÖVE E 8701 SNR 462638</b>	Active, automatic detection of the DUT connection, PCI + II
<b>A8</b>	<b>VDE 0701-0702 ÖVE E 8701 SNR 462638</b>	Active, automatic detection of the DUT connection, PCI + II
<b>A9</b>	<b>VDE 0701-0702 ÖVE E 8701-EDV SNR 462638-EDV</b>	Active, automatic detection of the DUT connection, PCI + II
<b>With feature KA01</b>		
<b>A7</b>	<b>IEC 60601 3<sup>rd</sup> edition</b>	Active, automatic detection, 1 group BF APPs A-K, PCI
<b>A8</b>	<b>IEC 60601 3<sup>rd</sup> edition</b>	Active, automatic detection, 1 group BF APPs A-K, PCII
<b>A9</b>	<b>IEC 60601 3<sup>rd</sup> edition</b>	Active, automatic detection, 1 group BF APPs A-E, PCI + II Active, automatic detection, 1 group CF APPs F-K, PCI + II

## Scope of Delivery

### Standard Version (country-specific)

- Test instrument **SECULIFE ST PRO**
- Mains power cable
- Test probe, 2 m, not coiled
- USB cable, USB A to USB B, 1.0 m long
- Plug-on alligator clip
- KS17-ONE cable set
- Calibration certificate
- Condensed operating instructions
- Comprehensive operating instructions available on the Internet
- Card with registration key for **IZYTRONIQ BUSINESS** Starter software (for download from the web)

Contents	Page	Page
<b>1 Applications .....</b>	<b>6</b>	<b>7 Notes on Saving Single Measurements and Test Sequences .. 27</b>
1.1 Table: Types of DUTs – Tests – Standards .....	6	7.1 QuickEdit Function – QEDIT
1.2 Table: Single Measurements – Standards .....	6	(feature KD01, “Z853S – SECUTEST DB COMFORT”) .....
<b>2 Safety Features and Precautions .....</b>	<b>7</b>	<b>8 Single Measurements .....</b>
2.1 Test Instructions for Applied Parts Measuring Functions .....	8	8.1 General .....
2.1.1 IP – Patient Leakage Current .....	8	8.2 Meaning of Symbols in the User Interface .....
2.1.2 IA – Leakage Current from the Applied Part .....	8	8.3 Displaying the Last Measured Values .....
<b>3 General Operation .....</b>	<b>10</b>	8.4 Measurement Series and Storage .....
3.1 Measured Value Display .....	10	8.5 Measuring Protective Conductor Resistance – RPE .....
3.2 Language, Keyboard Layout (culture parameter) .....	10	8.6 Insulation Resistance Measurement – RINS .....
3.3 Help Functions (HELP key) .....	10	8.7 Measuring Leakage Current .....
3.4 Entering Alphanumeric Characters .....	10	8.7.1 Protective Conductor Current – IPE .....
3.5 Print-Outs – Reports .....	10	8.7.2 Touch Current – IT .....
3.5.1 Multi-Print (multiple report print-out) .....	10	8.7.3 Device Leakage Current – IE .....
3.5.2 Report Template for Reading Out Reports to a Thermal Printer or an HTML File .....	10	8.7.4 Leakage Current from the Applied Part – IA .....
3.5.3 Test Report Settings in SETUP .....	11	8.7.5 Patient Leakage Current – IP .....
3.5.4 Report Tapes from Thermal Printers .....	11	8.7.6 Patient Auxiliary Current – IPA .....
3.5.5 Printing via <b>IZYTRONIQ</b> .....	11	8.8 Probe Voltage – U .....
3.5.6 Saving Reports to a USB Flash Drive .....	11	8.9 Measuring Voltage – U (feature I01) .....
3.6 Printing Out ID Labels .....	11	8.10 Function Test – P .....
3.7 Writing RFID Tags .....	11	8.11 Testing Extension Cords for Correct Function – EL1 .....
<b>4 Initial Startup .....</b>	<b>12</b>	<b>9 Special Functions – EXTRA .....</b>
4.1 Connecting the Test Instrument to the Mains .....	12	<b>10 Test Sequences .....</b>
4.1.1 Measurements in IT Systems (new parameter as of firmware 1.5.0) .....	12	10.1 General .....
4.1.2 Automatic Recognition of Mains Connection Errors .....	13	10.2 User-Defined Test Sequences / Remote Control
4.2 Connecting Test Probe P1 or P2 .....	13	(only with feature KB01, “Z853R – SECUTEST DB+”) .....
4.3 Device Settings .....	14	10.2.1 General .....
<b>5 Internal Database .....</b>	<b>18</b>	10.2.2 Testing of Probe Connection P1 and Probe Fuse P1 .....
5.1 Creating Test Structures, General .....	18	10.2.3 APP Fuse Test .....
5.2 Transmitting and Saving Test Structures and Measurement Data .....	18	10.3 General Settings (Setup: auto measurements parameter) .....
5.2.1 Export – Transmitting Test Structures and Measurement Data from the Test Instrument to the PC .....	18	10.4 Selecting and Configuring a Test Sequence .....
5.2.2 Import – Uploading Test Structures Created in the Report Generating Program to the Test Instrument (only with database extension or feature KB01, “Z853R – SECUTEST DB+”) .....	18	10.5 Connecting the DUT .....
5.2.3 Backing Up and Restoring Test Structures and Measurement Data .....	18	10.6 Selecting a Test Object .....
5.2.4 Switching Between 2 Tree Structure Views (at devices with database extension, feature KB01, “Z853R – SECUTEST DB+”) .....	20	10.7 Checking Connection and Starting the Test Sequence .....
5.3 Data Entry .....	21	10.8 Executing and Evaluating Test Steps .....
5.3.1 Keyboard Entries via Touchscreen or External Keyboard .....	21	10.9 Setting Limit Values Manually .....
5.3.2 Data Entry via the Touchscreen Keyboard (feature E01) .....	21	10.10 Ending the Test Sequence .....
5.4 Creating a Test Structure in the Test Instrument, Navigating within the Structure and Displaying Measured Values .....	22	10.11 Saving Test Results .....
5.4.1 General Procedure for Creating Test Structures .....	23	<b>11 Warnings, Error Messages and Notes .....</b>
5.4.2 Searching for Structure Elements .....	24	11.1 List of error messages .....
5.4.3 Display Measured Values from Saved Tests .....	24	11.2 List of Possible DUT Connections
5.4.4 Clearing the Database .....	24	Depending on Measurement Type .....
<b>6 Connecting the Device Under Test .....</b>	<b>25</b>	<b>12 Characteristic Values .....</b>
6.1 Residual Current Monitoring .....	25	<b>13 Maintenance .....</b>
6.2 Reference Voltage L-PE and Alternative Test Sequence .....	25	13.1 Housing Maintenance .....
6.3 Manually Specifying the Connection Type for Single Measurements .....	25	13.2 Testing the Color Display and the Buzzer (self-test parameter) .....
6.4 Manually Selecting a Connection Type / Protection Class for Automatic Test Sequences .....	25	13.3 Software Update (system info parameter) .....
6.5 Special Conditions .....	26	13.4 Backup Battery for Real-Time Clock .....
6.6 2nd Test Probe (feature H01) .....	26	13.5 <b>Fuse Replacement .....</b>
6.7 Connection Prompts .....	26	13.6 Recalibration .....
6.8 Connection Tests Conducted by the Test Instrument .....	26	13.7 Technical Safety Inspections .....
		13.8 Returns and Environmentally Sound Disposal .....
		<b>14 Appendix .....</b>
		14.1 List of Suitable Printers with USB Port .....
		14.2 List of Suitable Barcode Readers and RFID Scanners with USB Port .....
		14.3 Use of USB Storage Devices .....
		14.4 Bluetooth Interface ( <b>SECUTEST PRO BT (comfort)</b> or feature M01) .....
		14.5 Remote Control Interface .....

14.6	Entry via External USB Keyboard .....	109
14.6.1	Additional Key Functions (Feature KD01, "Z853S – SECUTEST DB COMFORT") .....	109
14.7	Classification of DUTs .....	109
14.7.1	Protection Classes .....	109
14.7.2	Applied Parts (electrical medical devices) .....	109
14.8	Maximum Permissible Limit Values for Leakage Current in mA .....	110
14.9	Index .....	111

15	Repair and Replacement Parts Service Calibration Center and Rental Instrument Service .....	113
16	Product Support .....	113

## 1 Applications

### 1.1 Table: Types of DUTs – Tests – Standards

DUTs to be tested in accordance with following standards	Initial Start-Up and Modifications	Testing after Repairs		Periodic Testing		Routine Tests		
	IEC 62353 DIN EN 62353 (VDE 0751-1)	DIN VDE 0701-0702	IEC 62353 DIN EN 62353	DIN VDE 0701-0702	IEC 62353 DIN EN 62353	DIN EN 60950/50116	DIN EN 61010	DIN EN 60335/50106 IEC 60601/DIN EN 60601
Laboratory devices, measurement and control devices		•		•			•	
Voltage generating devices		•		•				
Electric tools		•		•				•
Electric heaters		•		•				•
Devices with electric motors		•		•				•
Light fixtures		•		•				•
Consumer electronics, information and communication technology devices		•		•				•
Cable reels, extension cords and device connector cables		•		•				•
Data processing equipment and office machines		•		•		•		
Medical electrical equipment, applied parts	•		•		•			•



#### Attention!

The test instrument may not be used for measurements within electrical systems!



#### Attention!

The test instrument must be operated within the same electrical system as the test object!



#### Note

Test sequences for VDE 0701-0702, ÖVE 8701 and SNR 462638 are identical. In the interest of improved readability, only VDE 0701-0702 is described below. The explanations apply to ÖVE 8701 and SNR 462638 as well.

The instrument can be switched to the country-specific standard designation in SETUP (page 1/3) under "Auto Measurements", "Measuring Sequence Parameters".

### 1.2 Table: Single Measurements – Standards

Single Measurements per Standard	EN 50678, draft DIN VDE 0701-0702	IEC 62353 DIN EN 62353 (VDE 0751-1)	IEC 60601-1 DIN EN 60601-1 VDE 0750-1	IEC 60974-4 DIN EN 60974-4 VDE 0544-4
Protective conductor resistance	•	•	•	•
Insulation resistance	•	•		•
Protective conductor current	•			
Primary leakage current				•
Device leakage current		•		
Touch current	•	•	•	
Earth leakage current			•	
Current from welding circuit				•
(Individual) patient leakage current		•	• <sup>1</sup>	
Total patient leakage current			• <sup>2</sup>	
Patient auxiliary current			•	
Leakage current from the applied part		•	•	
<b>Test methods</b>				
Alternative measuring method				
Equivalent (device) leakage current	•	•		
Equivalent patient leakage current		•		
Differential current measuring method	•	•		•
Direct measuring method	•	•		•
SFC conditions	N		•	
	PE		•	
Mains voltage at applied part			•	

<sup>1</sup> 2<sup>nd</sup> and 3<sup>rd</sup> editions

<sup>2</sup> 3<sup>rd</sup> edition GPA

#### Key

- Specified test

## 2 Safety Features and Precautions

The test instrument fulfills all requirements of applicable EU directives and national regulations. We confirm this with the CE mark. The relevant declaration of conformity can be obtained from GMC-I Messtechnik GmbH.

The test instruments are manufactured and tested in accordance with the following safety regulations: IEC 61010-1 / DIN EN 61010-1 / VDE 0411-1, DIN EN 61557-16/VDE 0413-16.

Safety of the operator, as well as that of the test instrument and the device under test, is only assured when it's used for its intended purpose.

**Read the operating instructions carefully and completely before placing your test instrument into service. Follow all instructions contained therein. Make sure that the operating instructions are available to all users of the instrument.**

Tests may only be performed by a qualified electrician, or under the supervision and direction of a qualified electrician. The user must be instructed by a qualified electrician concerning performance and evaluation of the test.

Suitable personal safety equipment is required.

If you use active or passive body assistance, please consult with your physician or the manufacturer of the body assistance device.



### Note

Manufacturers and importers of medical electrical equipment must provide documentation for the performance of maintenance by trained personnel.

### Observe the following safety precautions:

- The instrument may only be connected to TN, TT or IT electrical systems with a maximum of 240 V which comply with applicable safety regulations (e.g. IEC 60346, VDE 0100) and are protected with a fuse or circuit breaker with a maximum rating of 16 A.
- Measurements within electrical systems are prohibited.
- Be prepared for the occurrence of unexpected voltages at devices under test (for example, capacitors can be dangerously charged).
- Make certain that the measurement cables are in flawless condition, e.g. no damage to insulation, no cracks in cables or plugs etc.
- When using a test probe with coil cord (SK2W): grip the tip of the test probe firmly, for example if it has been inserted into a jack socket. Tensioning at the coil cord may otherwise cause the test probe to snap back resulting in possible injury.
- **Measurement of insulation resistance and equivalent leakage current (alternative leakage current measuring method)**  
Testing is conducted with up to 500 V. Current limiting is utilized ( $I < 3.5$  mA), but if terminals L or N at the test socket or the test probe are touched, electrical shock may occur which could result in consequential accidents.
- **Leakage current measurement while connected to line voltage**  
It's absolutely essential to assure that the device under test is operated with line voltage during performance of the leakage current measurement. Exposed conductive parts may conduct dangerous touch voltage during testing, and may not under any circumstances be touched. (Mains power is disconnected if leakage current exceeds approx. 10 mA.)



### Attention!

The function test may only be performed after the DUT has successfully passed the safety test!

- **Probe test probe connection P1**  
Test the probe after completing each test (see also section 10.2.2).



### Attention!

If the fuse at test probe P1 is defective after testing has been started, all subsequent measurements conducted using this measuring path will be incorrectly evaluated as good!

#### • Fuse replacement

The fuses may only be replaced when the instrument is voltage-free, i.e. the instrument must be disconnected from mains supply power and may not be connected to a measuring circuit. The fuse type must comply with the specifications in the technical data or the labeling on the instrument.

### Connecting Line Voltage

Connecting line voltage to the test socket at the test instrument and performance of a function test are only permissible if the DUT has already passed all **safety test steps!** Depending on the DUT's protection class, this means that visual inspection, as well as measurement of protective conductor resistance and insulation resistance, must have been passed.

Do not start measurements at your test instrument unless the test instrument and the DUT are in plain view. Do not connect line voltage to the test socket of your test instrument before the surrounding area has been secured. This applies to individual measurements as well as to test sequences, and in particular to remote operation via the remote control interface.

### Switching Power Consumers – Procedure

Be absolutely sure to adhere to the sequence specified below when switching the live device under test. This prevents excessive wear of the mains relays at the test instrument.

#### Before measurement:

- 1 **Device under test:** Turn the DUT off via its own switch.
- 2 **Test instrument:** Switch line voltage to the test socket.
- 3 **Device under test:** Turn the DUT on via its own switch.

#### After measurement:

- 4 **Device under test:** Turn the DUT off via its own switch.
- 5 **Test instrument:** Deactivate line voltage to the test socket.

### Switching Loads – Maximum Starting Current

The test instrument permits **active** testing of devices with a nominal current (load current) of up to 16 A.

The test socket on the respective test instrument is equipped with 16 A fuses to this end, and the switching capacity of the internal relays is also 16 A. Starting current of up to 30 A is permissible.



### Attention!

Despite extensive protective measures targeted at preventing overloading, the relay contacts may be welded together if **starting current exceeds 30 A**. The following error message appears in this case:  
**"L(N) test socket fuse defective"**.

- ⇒ Check both of the mains connection's fuse links. If they're defective replace them with new ones.

If the error message described above still appears, it must be assumed that the relay is defective. If this is the case, the test instrument must be sent to our service department for repair (see section 15 for address).

### Safer Testing with Test Adapter

In the case of test objects for which a starting current of greater than 30 A can be expected, we urgently recommend the use of a test adapter for larger starting currents:  
for example test adapters from the AT3 series (AT3-IIIE, AT3-IIS, AT3-IIS32, AT16DI or AT32DI).

### Alternative: Passive Test

If necessary on the basis of the hazard assessment, testing can be conducted as a passive test (equivalent leakage current method), i.e. without switching line voltage to the test socket.



## 2.1 Test Instructions for Applied Parts Measuring Functions

The test instrument itself should be tested at regular intervals in order to assure the correctness of measurements and tests. This is possible by performing just a few measurements with a multimeter and the SECU-cal 10 calibration adapter. This applies in particular to measurements at the APP sockets because possible defects in the APP sockets' multiplexer are difficult to detect.

Please observe the additional operating instructions included with the SECU-cal 10 calibration adapter.

### 2.1.1 IP – Patient Leakage Current

#### Testing the Measuring Function

- ⇨ Connect the SECU-cal 10 to the test socket.
- ⇨ Select the “IP” measurement with the rotary switch.
- ⇨ Select the “Direct APP” measurement type:
- ⇨ Select single fault “PE interrupted” from the menu.
- ⇨ Select test condition “None” from the menu.
- ⇨ Set all APPs (A - K) to “on” in the menu.
- ⇨ Connect APP socket A to the 0.3 Ω socket at the SECU-cal 10.
- ⇨ Select the desired leakage current (e.g. 115 μA) at the SECU-cal 10.
- ⇨ Start the “IP Direct APP” measurement.
- ⇨ If the desired amperage does not flow, start the measurement again with reversed mains polarity.
- ⇨ If the desired amperage does flow, the APP socket is OK.
- ⇨ Connect the next APP socket to the 0.3 Ω socket at the SECU-cal 10.
- ⇨ This measurement must be repeated for all 10 APP sockets.
- ⇨ Stop the “IP Direct APP” measurement.

#### Testing the Isolating Function

- ⇨ Connect the SECU-cal 10 to the test socket.
- ⇨ Select the “IP” measurement with the rotary switch.
- ⇨ Select the “Direct APP” measurement type:
- ⇨ Select single fault “PE interrupted” from the menu.
- ⇨ Select test condition “None” from the menu.
- ⇨ Set only APP socket A to “on” in the menu.
- ⇨ Connect APP socket A to the 0.3 Ω socket at the SECU-cal 10.
- ⇨ Select the desired leakage current (e.g. 115 μA) at the SECU-cal 10.
- ⇨ Start the “IP Direct APP” measurement.
- ⇨ If the desired amperage does not flow, start the measurement again with reversed mains polarity.
- ⇨ If the desired amperage flows, connect APP socket B to the 0.3 Ω socket at the SECU-cal 10.
- ⇨ The display may not indicate any more than 10 μA at APP socket B.
- ⇨ Connect the next APP socket to the 0.3 Ω socket at the SECU-cal 10.
- ⇨ These measurements must be repeated at APP sockets C through K.
- ⇨ Then select APP socket B with the APP key.
- ⇨ Connect APP socket A to the 0.3 Ω socket at the SECU-cal 10.
- ⇨ The display may not indicate any more than 10 μA at APP socket A.
- ⇨ Stop the “IP Direct APP” measurement.

### Testing the Earthing of the Other APP Sockets

- ⇨ Connect the SECU-cal 10 to the test socket.
- ⇨ Select the “IP” measurement with the rotary switch.
- ⇨ Select the “Direct APP” measurement type:
- ⇨ Select single fault “normal status” from the menu.
- ⇨ Select test condition “APP > PE” from the menu.
- ⇨ Set only APP socket A to “on” in the menu.
- ⇨ Start the “IP Direct APP” measurement.
- ⇨ Measure resistance between APP socket B and the 0.3 Ω socket at the SECU-cal 10 with a multimeter.
- ⇨ Resistance must be less than 50 Ω.
- ⇨ These measurements must be repeated at APP sockets C through K.
- ⇨ Then select APP socket B with the APP key.
- ⇨ Measure resistance between APP socket A and the 0.3 Ω socket at the SECU-cal 10 with a multimeter.
- ⇨ Resistance must be less than 50 Ω.
- ⇨ Stop the “IP Direct APP” measurement.

### 2.1.2 IA – Leakage Current from the Applied Part

#### Testing the Measuring Function

- ⇨ Connect the SECU-cal 10 to the test socket.
- ⇨ Select the “IA” measurement with the rotary switch.
- ⇨ Select the “Direct APP” measurement type:
- ⇨ Set all APPs (A - K) to “on” in the menu.
- ⇨ Connect APP socket A to the 1 mA socket at the SECU-cal 10.
- ⇨ Start the “IA Direct APP” measurement.
- ⇨ The SECULIFE ST PRO should indicate approximately 1 mA.
- ⇨ If a significantly lower value is displayed, start the measurement again with reversed mains polarity.
- ⇨ If an amperage of approximately 1 mA is indicated, the respective APP socket is OK.
- ⇨ Connect the next APP socket to the 1 mA socket at the SECU-cal 10.
- ⇨ This measurement must be repeated for all 10 APP sockets.
- ⇨ Stop the “IP Direct APP” measurement.

#### Testing the Isolating Function

- ⇨ Connect the SECU-cal 10 to the test socket.
- ⇨ Select the “IA” measurement with the rotary switch.
- ⇨ Select the “Direct APP” measurement type:
- ⇨ Set only APP socket A to “on” in the menu.
- ⇨ Connect APP socket A to the 1 mA socket at the SECU-cal 10.
- ⇨ Start the “IP Direct APP” measurement.
- ⇨ The SECULIFE ST PRO should indicate approximately 1 mA.
- ⇨ If a significantly lower value is displayed, start the measurement again with reversed mains polarity.
- ⇨ If an amperage of approximately 1 mA is indicated, connect APP socket B to the 1 mA socket at the SECU-cal 10.
- ⇨ The display may not indicate any more than 10 μA at APP socket B.
- ⇨ Connect the next APP socket to the 1 mA socket at the SECU-cal 10.
- ⇨ These measurements must be repeated at APP sockets C through K.
- ⇨ Then select APP socket B with the APP key.
- ⇨ Connect APP socket A to the 1 mA socket at the SECU-cal 10.
- ⇨ The display may not indicate any more than 10 μA at APP socket A.
- ⇨ Stop the “IA Direct APP” measurement.





### Attention!

#### Dangerous Voltage at Connections or Contacts

When conducting measurements at APP sockets, APP sockets are connected together for the purpose of measurement or grounding depending on the selected settings at the test instrument, in the automatic sequences or in the PC software.

And thus in the event of damaged DUTs or faulty contacting, dangerous voltage may occur during testing at connections or contacts at which this isn't expected.

### Opening the Instrument / Repairs

The instrument may only be opened by authorized, trained personnel in order to ensure flawless operation and to assure that the guarantee isn't rendered null and void.

Even original replacement parts may only be installed by authorized, trained personnel.

If it can be ascertained that the instrument has been opened by unauthorized personnel, no guarantee claims can be honored by the manufacturer with regard to personal safety, measuring accuracy, compliance with applicable safety measures or any consequential damages.

If the guarantee seal is damaged or removed, all guarantee claims are rendered null and void.



### Attention!

Before opening the housing, pull the mains plug out of the outlet and wait for at least 5 minutes.

### The test instrument may not be used:

- If external damage is apparent, for example if parts which conduct dangerous touch voltage are freely accessible, if the display is broken or defective (in which case dangerous voltage or mains connection errors might no longer be indicated)
- If the seal or sealing lacquer has been removed as the result of repairs or manipulation carried out by an unauthorized/non-certified service provider
- With damaged connection and/or measurement cables and patient ports, e.g. interrupted insulation or kinked cable
- If the instrument no longer functions flawlessly
- After extraordinary stressing due to transport

In such cases, the instrument must be removed from operation and secured against unintentional use.

### Meanings of Symbols on the Instrument

The symbols on the instrument have the following meanings:



Warning regarding dangerous electrical voltage



Warning concerning a point of danger (attention: observe documentation!)



European conformity marking



This device may not be disposed of with household trash.

Further information regarding the WEEE mark can be accessed on the Internet at [www.gossenmetrawatt.com](http://www.gossenmetrawatt.com) by entering the search term "WEEE".



If the guarantee seal is damaged or removed, all guarantee claims are rendered null and void.

### Utilized Trademarks

#### QR Code

QR Code is a registered trademark of DENSO WAVE INCORPORATED



The **Bluetooth**<sup>®</sup> word mark and logo are registered trademarks of Bluetooth SIG, Inc.

## 3 General Operation

### 3.1 Measured Value Display

The following items appear at the display panel:

- The selected measuring function or standard
- Measured values with abbreviations and units of measure
- Setting parameters such as type of connection and measurement type
- Symbols for softkey operation
- Wiring diagrams, notes regarding the test sequence and error messages

Green progress bars appear in the header for single measurements, and orange progress bars appear for test sequences.

If the upper range limit is exceeded, the upper limit value is displayed and is preceded by the ">" symbol (greater than), which indicates measurement value overrun. Falling short of the lower range limit is indicated by the "<" symbol (less than), e.g. for RINS.



#### Note

The depiction of LEDs in these operating instructions may vary from the LEDs on the actual instrument due to product improvements.

### Measured Value Storage

See section 8.4

### 3.2 Language, Keyboard Layout (culture parameter)

The desired user interface language, a country-specific keyboard layout and a language for the test sequences (measuring sequence parameters) can be selected in the **SETUP** switch setting (see section 4.3).



#### Note

If you change the keyboard layout setting, you'll be prompted to scan in certain barcodes. This is necessary in order to assure that the barcode reader still works correctly **after** changing the language. If the barcode reader isn't currently available, you can subsequently set it to the new keyboard layout via Setup (2/3) > External Devices > Barcode Reader > Type Z751A.

### 3.3 Help Functions (HELP key)

Depending on the **rotary selector switch** position and the selected measurement type, appropriate wiring diagrams are displayed.

- ⇨ Press the **HELP** key in order to query online help.
- ⇨ Press the **ESC** key in order to exit online help.

### 3.4 Entering Alphanumeric Characters

#### Entry via the Keyboard

In addition to the softkey keyboard which can be accessed at the display, USB keyboards (with USB boot keyboard profile) can also be used to enter texts such as offsets, ID numbers, type designations and comments (see also section 5.3).

#### Reading in Barcodes

- ⇨ Correct recognition of the barcode scanner by the test instrument after connection to the USB port is indicated by the  icon in the header.
- ⇨ Select the following parameter in order to configure the barcode scanner for initial start-up:  
Setup (2/3) > External Device > Barcode Scanner > Type **Z751A**.
- ⇨ Scan the barcode which then appears.

When the menu for alphanumeric entry via the softkey keyboard is open at the display, any value read in by means of a barcode scanner is directly accepted.

See the appendix in section 14.2 concerning available accessory devices.



#### Note

We're unable to offer any guarantees regarding the use of scanning devices other than those listed in the appendix.

### Reading in an RFID Code

- ⇨ Correct recognition of the RFID scanner by the test instrument after connection to the USB port is indicated by the  icon in the header.

When held at a distance of about 3 cm directly in front of the middle of the RFID tag, the tag's current content is read (e.g. the ID code) and the SCAN LED on the reader blinks.

If the database view (MEM) is active (before or after a measurement), the cursor automatically jumps to the DUT with the corresponding ID code.

If the object isn't found, a prompt appears asking if you would like to create a new object.

### 3.5 Print-Outs – Reports

If you've connected a suitable printer (see list in appendix in section 14.1) or USB flash drive via the USB master port, you can read out a test report for each completed single measurement or test sequence by pressing the **PRINT** key.

The respective single measurement or test sequence must be previously selected in the memory menu with the help of the scroll keys.



#### Note

We're unable to offer any guarantees regarding the use of printers other than those listed in the appendix.

#### 3.5.1 Multi-Print (multiple report print-out)

If, in the memory menu, you move the cursor to a test object for which several tests have been conducted (individual measurements or test sequences) and press the **PRINT** key, a combined test report with all test results for the respective test object is read out.

#### 3.5.2 Report Template for Reading Out Reports to a Thermal Printer or an HTML File

A report can be read out showing the results of individual measurements or test sequences stored to the internal database. A report template is permanently stored to the test instrument for this purpose. The designation of the standard in the report may vary depending on which test sequence has been conducted.

The report template includes the following items:

- ID number
- Designation
- Customer name
- Location
- Date
- Time
- Comment with 64 characters
- Standard designation / sequence name / manual test
- Measured values
- Limit values
- Evaluations
- Test equipment (serial number)



#### Note

The display which appears isn't a print preview and does not reflect the actual appearance of the printout.

### 3.5.3 Test Report Settings in SETUP

The following settings can be entered with the switch in the SETUP position in menu 2/3 after opening the test reports menu:

Parameter	Settings
Visual inspection details	Visual inspection questions and corresponding answers are read out.
Text field in report	Entry of a fixed text block which is printed in all test reports.
Summarize test	On: Several test steps are combined into a single line. Off: A separate line is read out for each test step.
Location information	Information concerning the location at which testing was conducted can be shown or hidden.
Signature field	The report can be read out with (on) or without (off) a signature field.
Load logo from USB flash drive	After plugging in a USB flash drive to which a logo has been saved, the logo can be uploaded and saved to the test instrument (see section 3.5.4 regarding supported formats).
Display currently logo	A preview of the logo currently stored to the test instrument can be displayed by pressing this key.
Delete current logo	The logo which is currently stored to the test instrument can be deleted by pressing this key.

### 3.5.4 Report Tapes from Thermal Printers

Report tapes can be printed out with the Z721S thermal printer (accessory: Z722S thermal paper).

The test report can be edited and a company logo can be added to it directly in SETUP at the test instrument (see page 17). A company logo can be loaded from a USB flash drive for which the following image file formats are supported: BMP, JPG, PNG or GIF, max. resolution: 800 x 800 pixels, max. color depth: 24-bit.

### 3.5.5 Printing via IZYTRONIQ

Alternatively, stored measurement data can be read into IZYTRONIQ report generating software at a PC and printed out as a report.

### 3.5.6 Saving Reports to a USB Flash Drive

Select a measurement from the database view (**MEM** key) with the scroll keys, for which a report will be saved to a USB flash drive. Then press the **PRINT** key. "Print job finished" appears. The report is written to an HTML file. The filename consists of the timestamp and the ID of the test object.

Alternatively, reports can be save or printed out immediately after conducting a test, or when the test list view is open.



#### Note

A list of suitable USB flash drives is included in the appendix (see section 14).

### 3.6 Printing Out ID Labels

The following functions are made possible with the help of barcode printer:

- Print out ID numbers encrypted as barcodes for devices under test – for quick and convenient acquisition during periodic testing
- Print out repeatedly occurring designations such as test object types encrypted as barcodes in a list, allowing them to be read in as required for comments



#### Note

We're unable to offer any guarantees regarding the use of printers other than those listed in the appendix.

If you've connected a suitable barcode printer (see list in appendix in section 14.1) via the USB master port, you can print out a barcode for each test object by pressing the **PRINT** key.

- By viewing the printer information you can determine whether or not the connected barcode printer is correctly recognized by the test instrument:  
Setup (2/3) > Printer > Z721D > Printer Information  
or  
Setup (2/3) > Printer > Z721E > Printer Information
- Select encryption in Setup (paper size is set automatically as of FW 2.0):  
Setup (2/3) > Printer > Z721D > Printer Settings  
or  
Setup (2/3) > Printer > Z721E > Printer Settings
- Switch to the database view (**MEM** key).
- Select the desired test object with the scroll keys.
- Press the **PRINT** key.
- Depending on your selection, the ID is printed onto the label as a barcode. An error message appears if the ID cannot be read out as a barcode or a 2D code.



#### Note

##### Code Recognition

Please make sure that the printed codes are recognized by your scanner. Some code types have to be activated on your scanner prior to being used (this is frequently the case with Aztec/DataMatrix).



#### Note

##### Minimum Label Width

Tape cartridges with a minimum width of 12 mm are recommended for printing out 2D code labels (QR code, MicroQR code, DataMatrix, Aztec).

If a blank label is discharged upon printing an ID number as a 2D code with a 9 mm ribbon cartridge, replace it with a 12 mm cartridge (or wider) and restart the printing process.

### 3.7 Writing RFID Tags

The following function is made possible by an RFID scanner (programmer):

- Read out encrypted ID numbers for devices under test to an RFID tag for quick and convenient read-in during periodic testing

If you've connected a suitable RFID scanner (see list in appendix in section 14.1) via the USB master port, you can write an RFID tag for each test object by pressing the **PRINT** key:

- Correct recognition of the RFID scanner by the test instrument after connection to the USB port is indicated by the  icon in the header.
- Switch to the database view (**MEM** key).
- Select the desired test object with the scroll keys or enter a new test object by means of its ID.
- Briefly press the **PRINT** key on the test instrument.
- You're prompted to hold the scanner at a distance of about 3 cm directly in front of the middle of the RFID tag.

The "Successful write" message appears to indicate that the procedure has been completed.



#### Note

An error message appears if the ID cannot be converted to an RFID tag.



#### Note

We're unable to offer any guarantees regarding the use of readers or writers other than those listed in the appendix.

## 4 Initial Startup

### 4.1 Connecting the Test Instrument to the Mains

- See section 12 for nominal mains values (nominal ranges of use).
- Connect the test instrument to the mains cable via its inlet plug and insert the mains plug into an electrical outlet. The function selector switch can be set to any position. If a mains outlet (earthing contact outlet) isn't available, or if only a 3-phase outlet is available, the adapter socket can be used to connect the phase conductor, the neutral conductor and the protective conductor. The adapter socket has three permanently attached cables and is included with the KS13 cable set.



#### Attention!

If connection isn't possible via an earthing contact outlet: Shut down mains power first. Then connect the cables from the coupling socket to the mains using pick-off clips in accordance with the diagram. Disconnection from mains power is only possible via the mains plug.

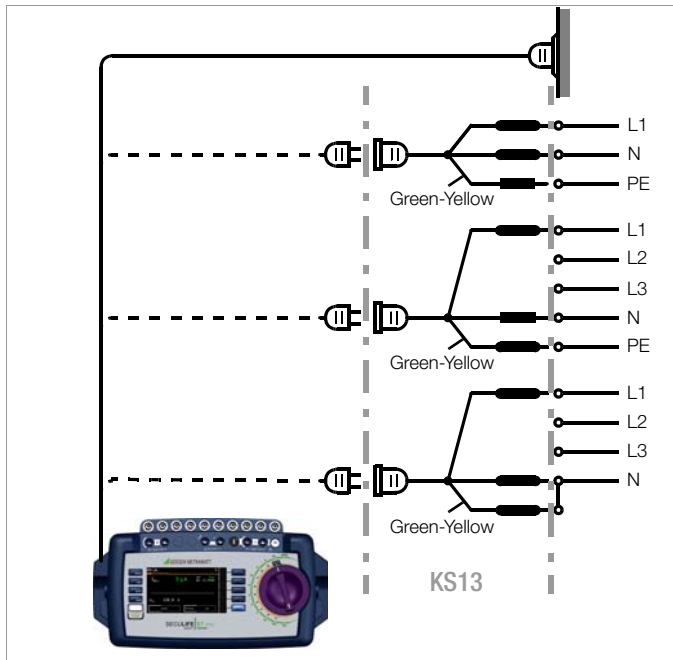

Figure 1 Connecting the Test Instrument to the Mains

### 4.1.1 Measurements in IT Systems (new parameter as of firmware 1.5.0)

The IT system setting can be activated for all single measurements and test sequences in the **SETUP** switch position (Setup 1/3) in the **All measurements** submenu (in this case the icon appears in the header of each display page):



with **“Measurement at IT system” set to Yes**: active leakage current measurements (or all measurements with reference to PE at the mains connection side) are disabled. Test sequences which include measurements of this sort are also disabled.

If, when being connected to line voltage, the test instrument detects a change at PE as compared with the previously used mains connection, the inspector is asked directly after initial start-up if the currently used outlet belongs to an IT system. The IT system option in **SETUP** is activated based on the user's answer. If **“Measurement at IT system”** is activated, this is indicated by the icon in the header.

Regardless of this, it's always possible to accordingly change the option manually in **SETUP**.

The setting for the **“Measurement at IT system”** option is retained even after disconnection from the mains.

In IT systems, active leakage current measurements (or any measurements with reference to PE at the mains connection side) do not deliver reliable measured values, for which reason all single measurements of this sort, as well as test sequences which include this type of measurement, are disabled when the **“Measurement at IT mains”** option has been activated in **SETUP**.

The **Meas. at IT mains** parameter can be set in Setup: Setup 1/3 > All Measurements > **Meas. at IT Mains**

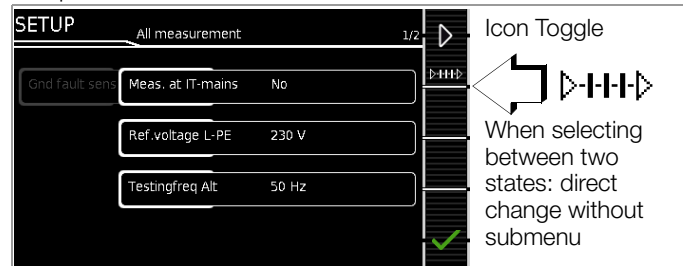

#### 4.1.2 Automatic Recognition of Mains Connection Errors

The device automatically recognizes mains connection errors if the conditions in the following table have been fulfilled. The user is informed of the type of error, and all measuring functions are disabled in the event of danger.

Type of Mains Connection Error	Message	Condition	Measurements
Voltage at protective conductor PE to finger contact (START/STOP key)	Display at the instrument	Press START/STOP button $U > 25 \text{ V}$ key $\rightarrow$ PE; $< 1 \text{ M}\Omega$ <sup>2</sup>	All measurements disabled
Protective conductor PE and phase conductor L reversed and/or neutral conductor N interrupted		Voltage at PE $> 100 \text{ V}$	Not possible (no supply power)
Line voltage $< 180 \text{ V} / < 90 \text{ V}$ (depending on mains)		$U_{L-N} < 180 \text{ V}$ $U_{L-N} < 90 \text{ V}$	Possible under certain circumstances <sup>1</sup>
Test for IT/TN system	Display at the instrument	Connection $N \rightarrow PE$ $> 20 \text{ k}\Omega$	Possible under certain circumstances

<sup>1</sup> 10/25 A R<sub>PE</sub> measurements are only possible with line voltages of 115/230 V and line frequencies of 50/60 Hz.

<sup>2</sup> If the user of the test instrument is too well insulated, the following error message may appear:  
"Interference voltage at mains connection PE"

#### 4.2 Connecting Test Probe P1 or P2

Insert the double plug from test probe P1 or P2 into socket 1 or 2 respectively such that the plug with the white ring makes contact with the socket with the vertical bar.

The white ring identifies the terminal for the high current conductor which is safeguarded by the neighboring fuse link.



#### Note

##### Difficulty in contacting exposed conductive parts when using the standard probe with test tip

In order to assure good contact, surface coatings must be removed from devices under test with special tools at a suitable location.

The tip of test probe P1 isn't suitable for scratching away paint, because this may impair its coating and/or mechanical strength. Brush probe Z745G may be more suitable than the test probe in certain individual cases.



#### Note

##### Finger Contact

During this test for correct mains connection, a voltage measurement is performed between the finger contact and PE at the test instrument's mains connection, and its reference potential is acquired via the user's body resistance to the conductive start key. In order to obtain reliable measurement results, this resistance value must be less than 1 M $\Omega$ . If the user is wearing insulating shoes or gloves, or is standing on an insulating floor covering, erroneous measurements and display of the "Interference voltage at mains connection PE" message may result. Try to reduce resistance in this case, for example by touching ground potential with the other hand (e.g. a radiator, but not an insulating wall etc.).



#### Attention!

If, while testing protective conductor potential, you determine that **the mains protective conductor is conducting voltage** (in accordance with the first two mentioned cases), **no further measurements may be performed with the test instrument**. If this is the case, potentially dangerous voltage is also present at the accessible earthing contacts of the standard socket (test socket). Immediately disconnect the test instrument from the mains and arrange to have the fault eliminated at the mains connection.



#### Note

**Voltage at the electrical system's protective conductor PE** may result in distorted measurement values during testing for the absence of voltage, or during leakage voltage measurements.

### 4.3 Device Settings

#### Setup



For the purpose of **initial start-up**, we recommend setting the following basic parameters in the order shown at the right:

- Setup 2/3 > Culture > **Language** (for user interface)
- Setup 2/3 > Culture > **Keyboard Layout** (for alphanumeric entries)
- Setup 1/3 > System > **Date / Time** (for report generation)
- Setup 1/3 > System > **Brightness** (display brightness as %)
- Setup 1/3 > Auto Measurements  
> 2/2 > Initial Window Style: **Tree or Detail View**

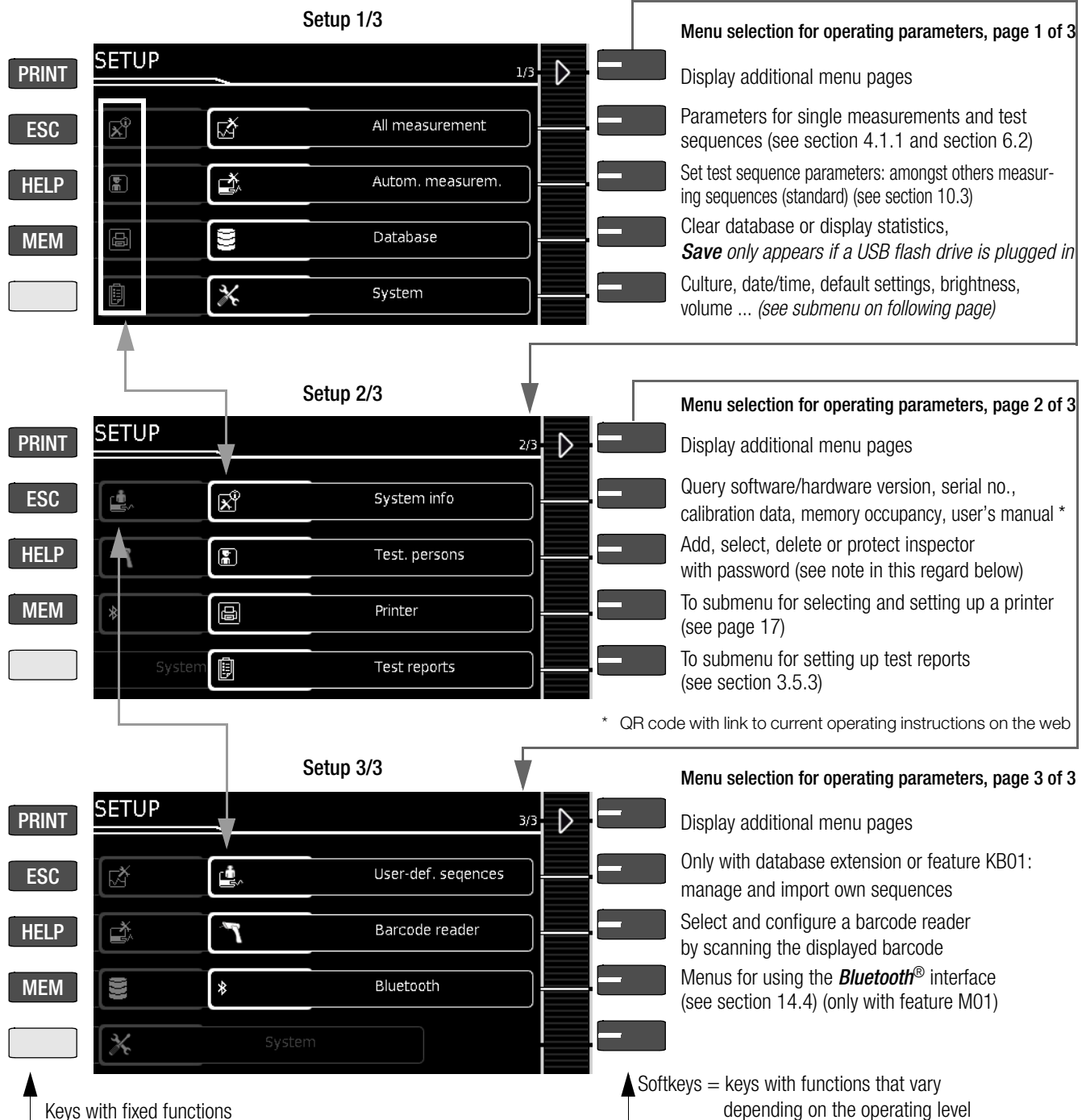

Figure 2 Device Settings, Main Menu Level – SETUP Switch Setting

The following parameters are advisable for **maintenance purposes**:  
 SETUP 3/3 > Test > **Display / Buzzer** (for checking info and warning displays/signals)

SETUP 3/3 > System Info > **Software Version** for updates (see section 13.3) and **Calibration Data** for adjustment, last and next calibration (see notes on bottom of page 15).

See section 13.3 regarding downloading the latest software version.

#### Notes Concerning the Inspector Parameter

- The inspector who has just been “selected” appears in completed tests as the “Inspector”. None of the test instrument's settings are stored specifically for the inspector – all of the set-

tings at the test instrument are stored for the respective device and are available to **all** inspectors.

- **If an inspector is password-protected**, this only prevents users who don't know the password from “selecting” this inspector. There's **no** password prompt when the test instrument is started up. The inspector remains selected even in the event of a power failure – a (password-protected) inspector can only be unselected by selecting another inspector.  
 In order to delete an inspector whose password you don't know, it's sufficient to enter an incorrect password five times in a row and to confirm the entry each time – a query then appears as to whether or not the inspector should be deleted. The inspector to be deleted may not be the same as the currently selected inspector.

Setup 1/3 > System 1/2

**Menu selection for operating parameters, page 1 of 2**

- Page 2/2
- Select language for user interface and keyboard  
*See settings menu below*
- Date and time setting menu  
*See settings menu below*
- Enable functions, display extras
- Reset to default values  
**Caution: The Setup configurations are deleted!** (also deletes list of inspectors, database content and company logo)

Setup 1/3 > System 2/2

**Menu selection for operating parameters, page 2 of 2**

- Page 1/2
- Brightness setting menu for LCD
- Volume setting menu  
*Messages, user interface, measurements*
- Calibrate touchscreen keyboard
- Self-test for display and buzzer

Setup 1/3 > System 1/2 > Culture

**Language/keyboard menu selection**

- Select language for user interface
- Country-specific keyboard layout for USB or touchscreen keyboard
- Info: Date format, decimal separator \*
- Jump back to next higher menu level

To parameters

Setup 1/3 > System 1/2 > Date / Time

**Set time and date menu**

- Move cursor left
- Move cursor right
- Increase number
- Decrease number
- Accept changes and jump back

Figure 3 Device Settings, Submenu Level – SETUP Switch Setting

ing the **EDIT** button as shown in the example above for setting system time.

**Notes on Calibration Data (adjustment, calibration)**

SETUP 3/4 > System Info 2/6 > **Calibration Data:**

Whereas data for the last adjustment and calibration were set at the calibration center, date and time of the next calibration (recalibration date) can be changed by the user if necessary by select-



Setup 1/3

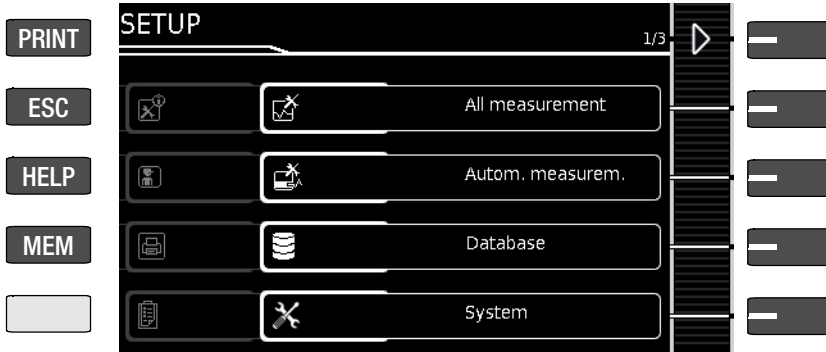

Setup 1/3 > Database 1/2

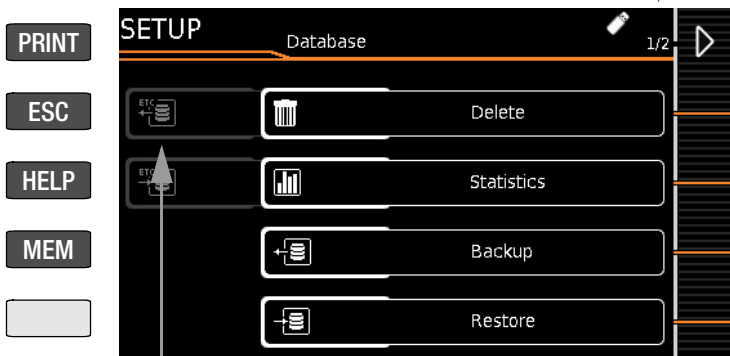

Menu selection for database functions, page 1 of 2

- Display additional menu pages
- Delete database content (but not its structure)  
**Note: Data are irretrievably deleted!**
- Display database statistics
- Only with inserted USB drive:  
Backup database to USB flash drive (FAT32 formatted)
- Only with inserted USB drive:  
Restore database from USB flash drive

Setup 1/3 > Database 2/2



Menu selection for database functions, page 2 of 2

- Display additional menu pages
- Only with database extension \* and inserted USB drive:  
Export database (".secu" file \*\*)
- Only with database extension \* and inserted USB drive:  
Import a database from a ".secu" file which has been created specifically for the SECUTEST/ SECULIFE ST with IZYTRONIQ.

\* Z853R or feature KB01  
\*\* Compatible with IZYTRONIQ

Keys with fixed functions

Softkeys = keys with functions that vary depending on the operating level



**Note**

**Changing the File Format**

Direct import of data in the old file format (".etc" file extension) is no longer possible as of firmware version 02.01.00.

Import the data into IZYTRONIQ report generating software first and then convert them to the new ".secu" file format. These data can then be imported to your test instrument with the help of a USB flash drive.

Backup files (.etcbak) from previous firmware versions are still compatible.

Printer Functions – Selection and Settings Using the Thermal Printer as an Example

**Setup 2/3 > Printer**

**Selecting the connected printer**

- Z721S printer: printer info / printer settings
- Z721D \* printer: printer info / printer settings  
\* Phase-out model
- Z721E \* printer: barcode label printer, printer info / printer settings  
\* For testing instrument firmware as of 1.8.3

**Setup 2/3 > Printer > Z721S**

**Retrieval of information or settings**

- Printer info: name, status, type
- Printer settings: parameters depend on printer type

**Thermal Printer > Settings1/2**

**Setting parameters**

- Switch to page 2/2
- Visual inspection details: show/hide
- Signature field: show/hide
- Location information: show/hide
- Delete a (company) logo previously loaded from a USB flash drive (see Settings 2/2).

**Thermal Printer > Settings 2/2**

**Load and display a logo from a USB flash drive**

- Switch to page 1/2
- Load a (company) logo from an inserted USB flash drive: selection list is displayed
- Display the currently loaded logo.
- Prerequisites for loading a logo: format: BMP, JPG, PNG or GIF, resolution: max. 800 x 800 pixels, color depth: max. 24-bit.

## 5 Internal Database

### 5.1 Creating Test Structures, General

A complete test structure with data regarding customer properties, buildings, floors, rooms and test objects can be created in the test instrument. This structure makes it possible to save the results of single measurements or test sequences to test objects belonging to various customers. Manual single measurements can be grouped together into a so-called "manual sequence".

Objects can be identified with the following parameters (**boldface** parameters are mandatory entry fields):

- **Device** (ID, designation, location, test interval \*, type, manufacturer, comment, serial number, protection class, cost center \*, department \*)
- **ME equipment** \*\* (ID, designation, **customer**, test interval \*, type, manufacturer, comment, serial number, protection class, number of type B applied parts \*\*, number of type BF applied parts \*\*, number of type CF \*\* applied parts, cost center, department, UDI \*\*, mains connection \*\*)
- **Room** \* (ID and **designation**)
- **Floor** \* (ID and **designation**)
- **Building** \* (ID, **designation**, street, ZIP code and city)
- **Property** \* (ID and **designation**)
- **Customer** (ID, **designation**, street, ZIP code and city)

#### Key

ID = identification number

### 5.2 Transmitting and Saving Test Structures and Measurement Data

The following functions are possible (as far as the test instrument is concerned):

- **Export**: Transfer a structure including measured values from the test instrument to the PC (ETC \*\*\* or **IZYTRONIQ**) (see section 5.2.1).
- **Import** \*: Transfer a test structure from the PC (**IZYTRONIQ**) to the test instrument (see section 5.2.2).
- **Backup** \*: Back up a database to a USB flash drive plugged into the test instrument (must be FAT32 formatted – not NTFS) (see section 5.2.3).
- **Restore** \*: Restore a database to the test instrument from a USB flash drive plugged into the test instrument (must be FAT32 formatted – not NTFS) (see section 5.2.3).
- **Reports**: Save reports to a USB flash drive (see section 3.5.6).

If no USB flash drive has been plugged in, the above listed functions are grayed out and disabled.

In order to transfer structures and data, the test instrument and the PC must be connected with a USB cable or a USB flash drive must be available.

#### Please observe the following safety precautions:



#### Attention!

During data transmission via the USB port (USB connection to the PC or connection of a USB flash drive), neither the interface cable nor the USB drive may be disconnected.



#### Attention!

The test instrument may not be disconnected from supply power during transmission via the USB port. The memory structure in the test instrument might otherwise be destroyed.



#### Note

Data transfer to the PC should not be started during single measurements or test sequences.

### 5.2.1 Export – Transmitting Test Structures and Measurement Data from the Test Instrument to the PC

Structures set up in, and measurement data saved to the test instrument can be exported to **IZYTRONIQ** report generating software via a connected USB flash drive (only with data base extension or feature KB01, "Z853R – SECUTEST DB+"), or via the USB slave port. Select **Export IZY file** under Setup > Database 2/2 to this end. The data are converted to an **IZYTRONIQ**-compatible format with the ".secu" file extension.

The report generating program is started at the PC by double clicking the exported file and the data are read in. Data can then be saved to the PC and reports can be generated.

### 5.2.2 Import – Uploading Test Structures Created in the Report Generating Program to the Test Instrument (only with database extension or feature KB01, "Z853R – SECUTEST DB+")

As an alternative, a test structure can be created at the PC with the help of the report generating program and then transferred to the test instrument via a connected USB flash drive, or via the USB slave port. Select the **Import IZY file** function to this end under Setup > Database 2/2. The data are converted to a format which is compatible with the test instrument.

A complete description of database creation can be found in the online help included with the report generating program.

The same backup files apply here as is also the case in the section covering export.

### 5.2.3 Backing Up and Restoring Test Structures and Measurement Data

Structures created and measurement data saved at the test instrument can be backed up via an inserted USB flash drive (must be FAT32 formatted – not NTFS). Select the **Backup** function to this end under Setup > Database 2/2.

The test instrument creates a backup file on the USB flash drive directly in the root directory.

The backup files on the USB flash drive are named by means of a time stamp (file extension: .etcbak).

In order to restore structures and data from an inserted USB flash drive, select the **Restore** function under Setup > Database 2/2. When restoring, the files from the root directory are displayed as well as those from the backup folder (which used to be created in previous firmware versions). The files from the backup folder are displayed with the ">" prefix.



#### Note

#### Backup/Restore to/from USB Flash Drive

It's also possible to restore backup files created with previous firmware versions.



#### Attention!

During data backup via the USB port (USB connection to the PC or inserted USB drive), neither the interface cable nor the USB drive may be disconnected. If the USB drive is removed during the backup it may be rendered defective.



#### Attention!

The test instrument may not be disconnected from supply power during data backup via the USB port.

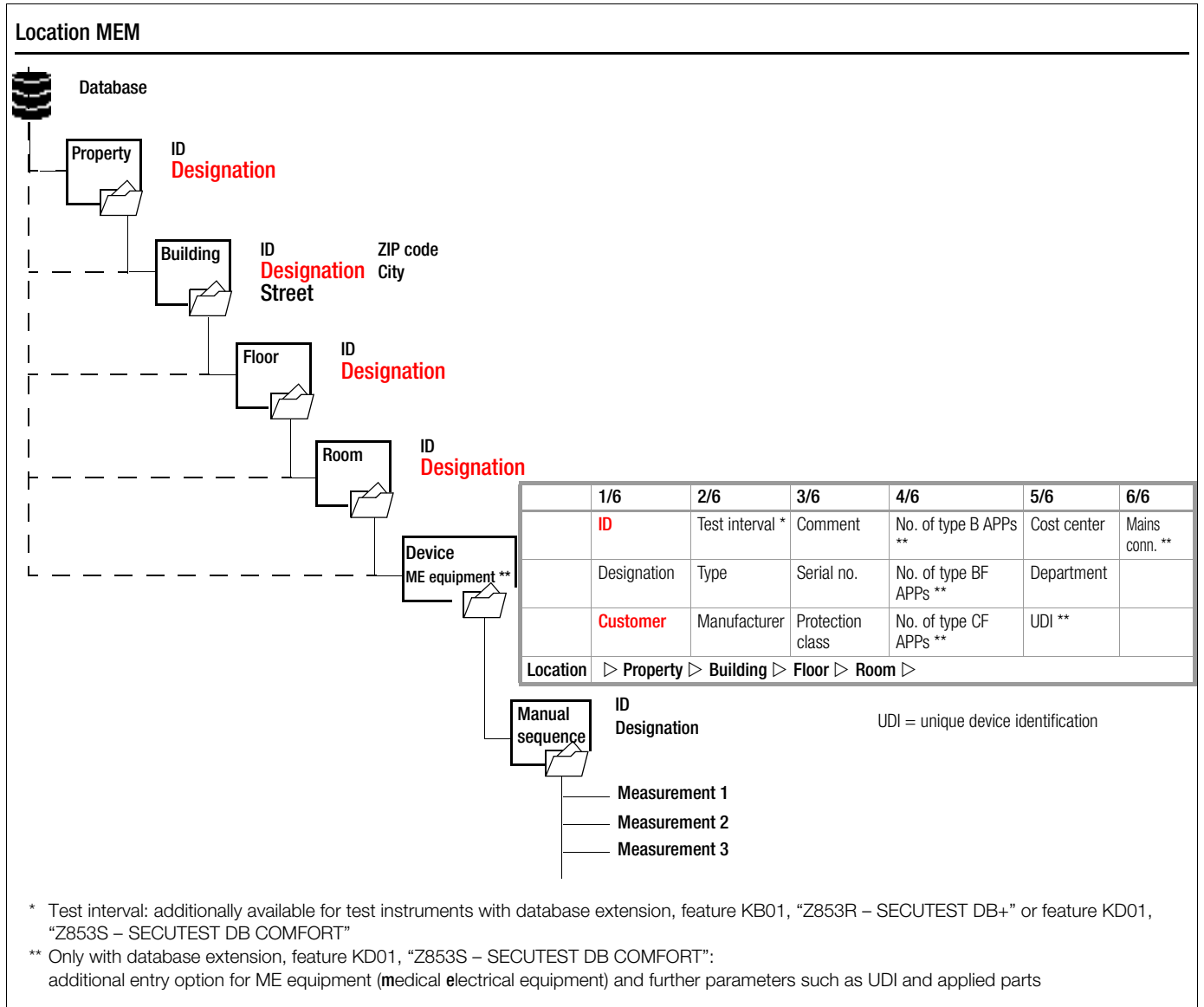

Figure 4 Database Structure as Location View in Test Instruments with Feature KB01, “Z853R – SECUTEST DB+”

## Test Structure, Customer View – Hierarchy of Object Levels in Devices with Database Extension, Feature KB01, “Z853R – SECUTEST DB+”

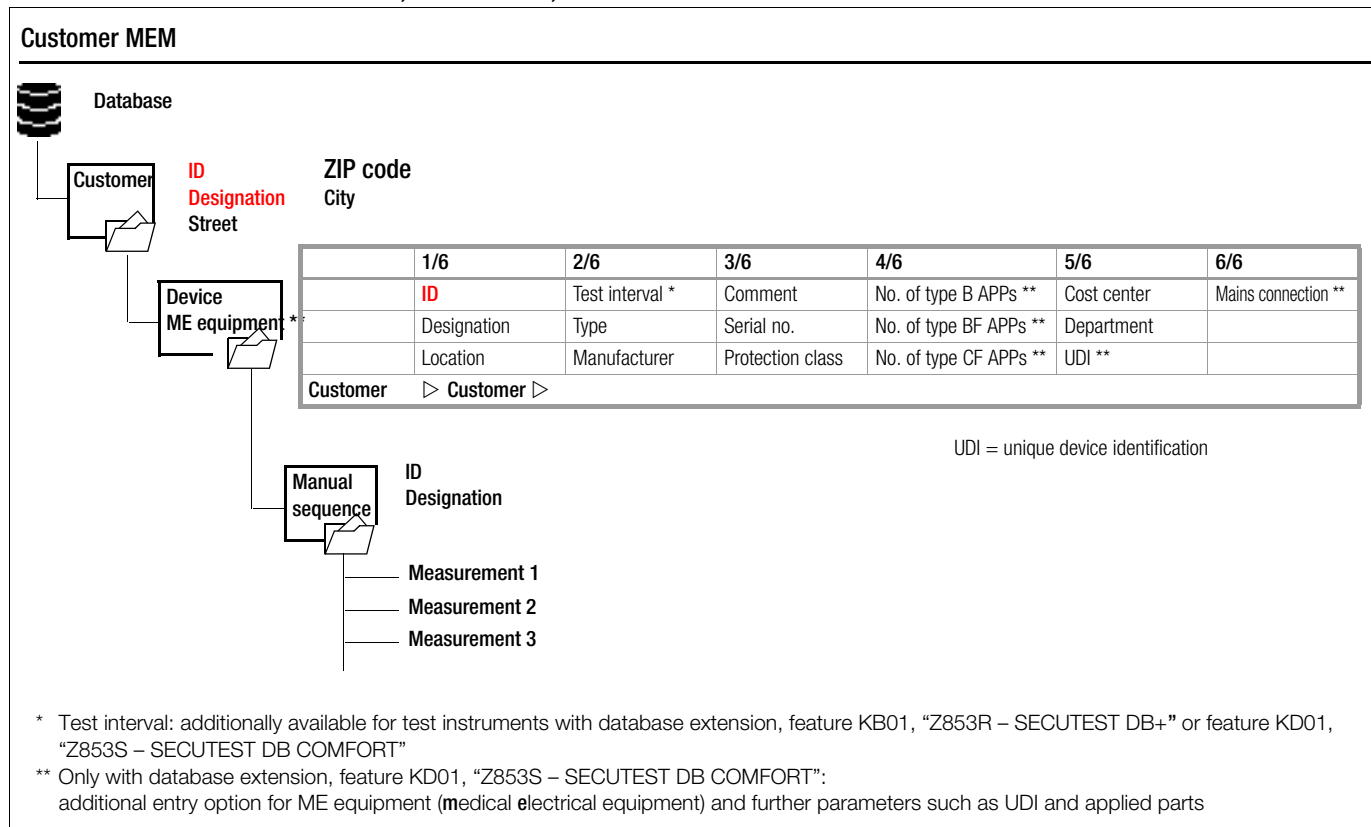

Figure 5 Database Structure as Customer View in Test Instruments with Feature KB01, “Z853R – SECUTEST DB+”



### Note Grayed Out Database Elements

The corresponding elements are grayed out in devices without enabling for the following options: “extended database structure”, feature KB01, “Z853R – SECUTEST DB+” (= property, building, floor, room) or feature KD01, “Z853S – SECUTEST DB COMFORT” or medical electrical equipment.



### Note Mandatory Entries

Mandatory entries are identified in red in the entry fields at the test instrument as well as in the illustrations in Figure 4 and Figure 5.



### Note Hierarchies

The following hierarchies must be complied with:  
**Room or Floor** must always be subordinate to **Building**.  
**Devices or ME equipment** (medical electrical equipment) must always be allocated to a **Customer**.

## 5.2.4 Switching Between 2 Tree Structure Views (at devices with database extension, feature KB01, “Z853R – SECUTEST DB+”)

- ⇒ The display can be switched back and forth between the location and customer views by repeatedly pressing the **MEM** key.
- ⇒ The database view can be exited by pressing the **ESC** key.

## Hierarchies and Data Migration

Database objects “Device” and “ME equipment” must always be subordinate to a Customer. If so-called “legacy data” have been imported into the test instrument which do not comply with this rule (e.g. as a result of a firmware update or via the “Restore database” function), Customer objects are generated automatically. The same applies to database objects “Room” and “Floor”, which must always be subordinate to a Building. In this case, Building objects are generated automatically if necessary.

## 5.3 Data Entry

### Overview of Keyboard Entries via the Touchscreen Keyboard (feature E01)

- ⇨ Briefly pressing the shift key once causes the next character to appear in uppercase.
- ⇨ Pressing the shift key for a longer period of time causes all following characters to appear in uppercase.
- ⇨ The cursor can be positioned as desired by pressing the display panel at the respective point in the existing text.

\* Also via assigned softkey

Delete characters from right \*

Accept entry \*

#### 5.3.1 Keyboard Entries via Touchscreen or External Keyboard

After selecting **ID** or any other object parameter, a keyboard is displayed which allows for the entry of alphanumeric characters via the fixed function keys and the softkeys. Alternatively, entries can also be made with the help of a USB keyboard or barcode scanner which is connected to the instrument.

The keyboard layout can be matched to the language in **SETUP**. Setup 1/3 > System 1/2 > Culture > **Keyboard Layout** (for alphanumeric entries)



#### Note

In order to use a USB keyboard at the SECUTEST..., the "Keyboard Layout Settings" in Setup must coincide with the connected keyboard.

See section 14.6 concerning switching to an external USB keyboard and special key functions.

#### Procedure (example: entering a designation):

- 1 Switch the keyboard back and forth between uppercase and lowercase with the  $\uparrow$  button.
- 2 Select entry of numbers, special characters or letters via the keyboard with the "123", "sym" or "abc" button.
- 3 After pressing the respective icon it appears at the display panel.
- 4 Repeat steps 1 through 3 until the complete designation is shown at the display panel.
- 5 The value appears at the display after pressing the green checkmark.



#### 5.3.2 Data Entry via the Touchscreen Keyboard (feature E01)

The touchscreen keyboard permits convenient entry of data and comments, selection of parameters and direct parameter selection, and menu-driven operation is still possible via the softkeys as an alternative.

#### Meaning of Symbols in the User Interface – Database Management

Symbol	Meaning
Main Level	Sub-level
<b>Memory menu, page 1 of 3</b>	
	Change display to menu selection
	Cursor UP: scroll up
	Cursor DOWN: scroll down
	Cursor RIGHT: open tree
	Cursor LEFT: close tree
<b>Memory menu, page 2 of 3</b>	
	Change display to menu selection
	Add a structure element
	Delete selected structure element or measurement
	Edit structure element (ID, designation, comment ...)
	Move structure element (feature KD01, "Z853S – SECUTEST DB COMFORT")
	When a measurement is selected: Display measured values
	Display details from the measurement results list
	Hide details from the measurement results list
<b>Memory menu, page 3 of 3</b>	
	Change display to menu selection
	Search for ID, text or UDI > enter complete ID number (ID) or text (complete word)
	Search for ID number: > Enter complete ID number of a test object
	Confirm search results
	Display the structure designation
	Hide the structure designation

## 5.4 Creating a Test Structure in the Test Instrument, Navigating within the Structure and Displaying Measured Values

### Overview of the Meanings of the Symbols for Creating Objects – Navigation within Test Structures

**MEM 1/3**

**Object selection menu – page 1/3**

- Scroll to next menu (page 2/3)
- Select customers or devices
- Select customers or devices
- Jump back (one hierarchical level higher) or close open branches
- Select customers or devices

**MEM 1/3**

**Measurement selection menu – page 1/3**

- Scroll to next menu (page 2/3)
- Selection of measurements
- Selection of measurements
- Jump back (one hierarchical level higher) or close open branches
- Display measured values for a selected test
  - 1: Test sequence per standard (symbol: orange)
  - 2: Single measurement (symbol: green)

**MEM 2/3**

**Object editing menu – page 2/3**

- Scroll to next menu (page 3/3)
- Add new (ME) device to the selected customer or clone current element (as of firmware 3.0)
- Either "Delete selected customer, (ME) device or measurement" or "Delete selected object with all subordinate objects/measurements"
- Edit device/customer
- Move object

**MEM 3/3**

**Object search menu – page 3/3**

- Scroll to next menu (page 1/3)
- Search by entering text
- Search by entering IDs
- Display designation and ID of the selected device

Note: See page 20 concerning grayed out database elements.

Figure 6 Overview of Navigation, Object Editing and Object Search in the Database



### 5.4.1 General Procedure for Creating Test Structures

After selection with the **MEM** key, all setting options for the creation of a tree structure are made available on three menu pages (1/3, 2/3 and 3/3). The tree structure consists of structure elements, referred to below as objects.

Results of measurements/tests can only be saved under structure element types "Device" or "ME equipment" (medical electrical equipment), which are also referred to as "test objects" in the following.

#### Select the position at which a new object will be added.

- Use the ▲ or ▼ key in order to select the desired structure elements.
- If a sublevel exists, you can switch to it by pressing the ► key, or you can open a branch.
- The open branch is then closed, or you can switch to the next higher hierarchical level, by pressing the ◀ key.

#### Creating a New Object

- Scroll to the second menu page (MEM 2/3) with the help of the ►► key.
- After pressing **NEW**, a new object can be created. Depending on the current position within the hierarchy, the respectively available object types are suggested. Depending on the object type, you'll have to enter at least an ID number via the keyboard. If any of the mandatory entries (identified in red) have not been completed, an error message appears.
- Then press the green checkmark in order to accept the entered values. The display jumps back up to the higher hierarchical level. ✓

#### Move an Object (feature KD01, "Z853S – SECUTEST DB COMFORT")

- Scroll to the first menu page (MEM 1/3) with the help of the ►► key.
- Select the object to be moved (together with sub-objects) with the scroll keys.
- Scroll to the second menu page (MEM 2/3) with the help of the ►► key.
- Press the **MOVE** icon.
- Using the scroll keys, select the position to which the object is to be moved and confirm by pressing the green checkmark.

#### Quick Command: Move Object (feature E01 (touchscreen) and feature KD01, "Z853S – SECUTEST DB COMFORT")



- Press and hold the object to be moved in the tree view in the initial window of a test sequence until the activity bar starts to blink.



#### Note

Depending on whether or not finger pressure is applied for a longer period of time in the customer or location tree, the device can be "moved" to another customer or "moved" between locations.

- Upon releasing finger pressure, the display is automatically switched to the database view (MEM), from where you can proceed to the "Move" menu.

- Now select the position with the scroll keys to which the object will be moved.
- The display is automatically returned to the initial window after confirming with the green checkmark.

#### Editing an Object – Changing the Description or ID Number of a Previously Created Object

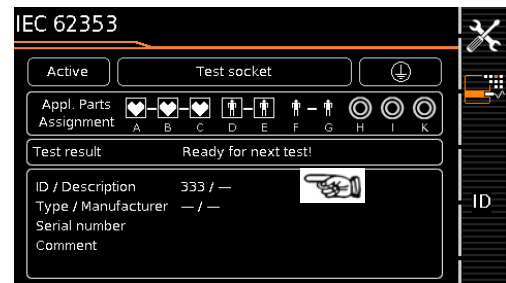

- Scroll to the first menu page (MEM 1/3) with the help of the ►► key.
- Select the structure element whose designation will be changed.
- Scroll to the second menu page (MEM 2/3) with the help of the ►► key.
- Press the **EDIT** icon.
- Select the parameter whose description will be changed. The keyboard appears automatically.
- Change the displayed designation and acknowledge your entry.

#### Quick Command: Edit Object (feature E01 (touchscreen) and feature KD01, "Z853S – SECUTEST DB COMFORT")



- Press and hold a point in the detail view field in the initial window of a test sequence until the activity bar starts to blink.
- Upon releasing finger pressure, the "Edit" menu for a device/ME equipment (medical electrical equipment) opens automatically.
- After entering or changing the data, the display is automatically returned to the initial window upon confirming with the green checkmark.

## 5.4.2 Searching for Structure Elements

- ⇨ Scroll to the first menu page (MEM 1/3) with the help of the  key.
- ⇨ Scroll to the third menu page (MEM 3/3) with the help of the  key.
- ⇨ Press the text symbol in order to search for text.
- ⇨ Press the ID symbol in order to search for an ID number.  
There are three ways to enter search terms:
  - Via the softkeys
  - Via a connected USB keyboard
  - Via a barcode or an RFID scanner

The keyboard entry function is opened automatically in either case.

- ⇨ The search is started after the entered search term has been acknowledged.



### Note





When searching for IDs, differentiation is made between uppercase and lowercase.

When searching for text, elements are found regardless of whether they're written in upper or lowercase.

The found object is displayed inversely.

- ⇨ If several objects are found which match the search string, you can toggle with the scroll keys between the different search results.
- ⇨ The designation and ID number can be shown or hidden by pressing the magnifying glass symbol.

## 5.4.3 Display Measured Values from Saved Tests

- ⇨ Switch to the database view by pressing the **MEM** key.
- ⇨ Scroll to the first menu page (Navigation) (**MEM 1/3**) with the help of the  key.
- ⇨ Either select the desired object (ID number) with the scroll keys or search for it as described in section 5.4.2.
- ⇨ Then mark the desired test with the cursor, depending on whether single measurements or test sequences are involved:  
Single measurements: **date / measuring function (3/12/2019 / RINS)**  
Test sequence: **date / test standard (3/12/2019 / VDE ...)**
- ⇨ In order to view the single measurements of a test sequence after testing, press the icon for executed measurements. The measurements appear in a list. 
- ⇨ Select the desired measurement with the scroll keys. 
- ⇨ The associated measuring parameters can be shown or hidden using the keys shown at the right. 
- ⇨ The measured value view is exited by pressing the green checkmark.

## 5.4.4 Clearing the Database

The database in the test instrument can be cleared in two different ways:

- **SETUP** switch setting, page 1/3 > Database > **Delete**
- Press the **MEM** key > scroll up with the scroll key until the database is selected > press the **DEL** softkey.

## 6 Connecting the Device Under Test

- ⇨ Connect the DUT in accordance with the schematic diagrams included in the online help function.

Connection of the DUT to the test instrument depends on:

- **The type of DUT:**

**For direct connection to the test socket (TS)**

Devices with single-phase connection and extension cords via the **EL1** adapter (in which case the EL1 is connected to probe sockets P1)

**For permanent connection (to the mains)**

by contacting the housing with the probe (for the *measurement of protective conductor resistance* or with the direct measuring method for the touch current measurement)

*Measurement of protective conductor current* with a current clamp (only possible with feature I01)

**For connection via adapter**

- With *single-phase extension cords* via the **EL1** adapter (in which case the EL1 is connected to probe sockets P1)
  - With single and *3-phase extension cords* via the **VL2E** adapter to the test socket
  - Devices with 5-pole, 16 A CEE plug via the **AT16-DI** differential current adapter to the test socket
  - Devices with 5-pole, 32 A CEE plug via the **AT32-DI** differential current adapter to the test socket
- **DUT protection class** (PC I, PC II or PC III) or any combinations of protection categories



### Note

The DUT must be switched on for all tests. Switches, relays, temperature regulators etc. must all be taken into consideration.

As a default setting, the program sequence assumes that the plug from the DUT has been connected to the test socket.

### 6.1 Residual Current Monitoring

For your safety, the test instrument is equipped with continuous residual current monitoring. If residual current exceeds a specified limit value, all measuring processes are stopped, and if line voltage is fed through the test socket it's disconnected. This limit value can be set to one of two levels in the **SETUP** switch position:

Setup 1/3 > All Measurements > Residual Current Protection > **10 mA/30 mA**

### 6.2 Reference Voltage L-PE and Alternative Test Sequence

#### Specifying Reference Voltage L-PE

Reference (line) voltage is the voltage to which the measured values for leakage current have been standardized.

It's used in the case of leakage current for mathematical adaptation of measured current values to the specified voltage.

**Measurements with line voltage at the test socket:** The setting value has no influence on the voltage with which the test object is supplied via the test instrument's test socket.

**Leakage current measurements with "Alternative" method:** The set-point value of the synthetic test voltage is derived from the value specified here.



### Note

The displayed measured values for leakage current are standardized to an adjustable reference value (typically 230 V) in order to permit reproducible measurement of leakage current even with fluctuating mains supply voltage.

Reference voltage can be adjusted in Setup:  
Setup 1/3 > All Measurements > **Ref. Voltage L-PE**

### Specifying an Alternative Test Frequency

Selectable frequency setpoint value for synthetic test voltage for all leakage current measurements of measurement type "Alternative", affecting the following measurements and/or rotary selector switch positions:

- Single measurements (rotary switch level: green)
- Measurements included in predefined default test sequences
- Measurements included in user-defined test sequences (only with database extension, feature KB01, "Z853R – SECUTEST DB+")

The **Alt. Test Freq.** parameter can be set in Setup:  
Setup 1/3 > All Measurements > **Alt. Test Freq.**

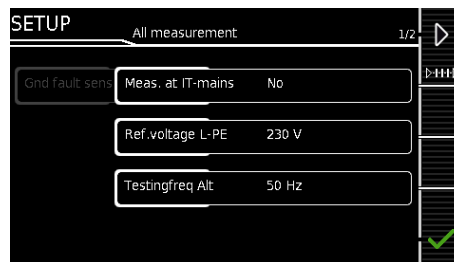

### 6.3 Manually Specifying the Connection Type for Single Measurements

In the case of single measurements the test instrument is unable to detect the respective **connection type** (e.g. test socket or permanent connection (voltage measuring inputs)). The connection type must be specified manually.

- ⇨ Select **parameter settings**.



- ⇨ After selecting the **measurement type** parameter, a list of possible connection types is displayed.
- ⇨ Select a **connection type**.

Once a connection type has been selected, it remains active for all following tests until it's changed again.

### 6.4 Manually Selecting a Connection Type / Protection Class for Automatic Test Sequences

If the test instrument is unable to detect the respective connection type or protection class, the suggested connection type must be examined and the connection type or protection class must be specified manually if necessary.

- ⇨ Press the **Sel** key shown at the right in order to display the **Classific. parameters**.
- ⇨ After selecting the **protection class** or **connection type** parameter, a list of possible settings is displayed.
- ⇨ Select the respective parameter.
- ⇨ Acknowledge the **Class. Param.** (classification parameters) once again.  
The connection type appears at the middle of the header.  
The symbol for the respective protection class appears to the right of the connection type.



Once a connection type or a protection class has been selected, it remains active for all following tests until it's changed again.

## 6.5 Special Conditions



### Note

#### Protection Class II Devices with Protection Class I Mains Plugs

If the device under test is equipped with a protection class I plug although it complies with protection class II, protection class I is recognized by the test instrument. If this is the case, switch the protection class parameter from I to II.

### Testing Several Protective Conductor Connections with the Function for “Automatic Detection of Measuring Point Changes”

During protective conductor measurement, the test instrument recognizes whether or not test probe P1 is in contact with the protective conductor, which is indicated by means of two different acoustic signals. This function can be adjusted in the **SETUP** switch position in the “Auto Measurements” submenu via the “Auto Measuring Point” parameter.

### Protective Conductor and Insulation Resistance Measurements for Permanently Installed DUTs



### Attention!

Deactivate the electrical system which supplies power to the device under test before connecting the test instrument!

- Remove the mains fuses from the device under test and disconnect neutral conductor N inside the device under test.

### Touch Current Measurement (absence of voltage)

Make sure that the contacted parts are not grounded.

## 6.6 2<sup>nd</sup> Test Probe (feature H01)

If the device under test isn't equipped with a country-specific mains plug which fits into the test socket at the test instrument, or if a permanently installed DUT is involved, the second test probe, in combination with the first test probe, permits 2-pole measurement (dual-lead-measurement) of RPE, RINS and equivalent leakage current.

Measurements with test probe 1 to test probe 2 (P1 – P2) are electrically isolated from the mains. There's no voltage at the test socket.



### Attention!

Please note that during insulation measurement the maximum test voltage of 500 V may be applied between the probes.

## 6.7 Connection Prompts

If a single measurement (green rotary switch positions) or a specific (integrated) automatic test sequence (orange rotary switch positions) is started, checking is conducted to determine whether or not all of the probes and measurement cables required to this end are connected (depending on the configuration level of your SECUTEST...). If this isn't the case, you're prompted to connect probes, measurement cables or the test adapter to the SECUTEST...

Checking is only conducted to determine whether or not the corresponding sockets are occupied – make sure that suitable accessories have been connected for the selected measurement/connection type.

A list of possible DUT connections depending on type of measurement is included in section 11.2.

## 6.8 Connection Tests Conducted by the Test Instrument

The following measurements are performed automatically when the DUT is connected to the test instrument.

### • Detection of Probes / Measurement Cables

During individual measurements / automatic test sequences, checking is conducted to determine whether or not the measuring sockets required for the measurement/sequence are occupied.

- DUT connection detection** (only with country-specific variant \*)  
With the rotary switch in the A1-A9 position, the “Test Socket” connection type is selected automatically (if correspondingly configured), if a mains plug is detected in the test socket.
- Protection class detection** (only with country specific variant \*):  
With the rotary switch in the A1-A9 position, protection class I or II is selected (if correspondingly configured), depending on the detected type of mains plug.
- Short-circuit test**  
Before switching mains voltage to the device under test: test for short-circuiting between L and N or L/N and PE – if applicable additionally as an “inspection test step” in automatic test sequences.
- On test** (test whether the DUT is switched on or off)

### Automatic Recognition of States when Connecting DUTs and Probes

Test Function	Condition	
<b>Short-circuit test</b> L–N	Short-circuit / DUT starting current	$R \leq 2.5 \Omega^2$
	No short-circuit (AC test)	$R > 2.5 \Omega^2$
Open-circuit voltage $U_0$ 4.3 V, short-circuit current $I_k < 250$ mA		
<b>Short-circuit test</b> LN–PE	short-circuit	$R \leq 2$ k $\Omega$
	No short-circuit (AC test)	$R > 2$ k $\Omega$
Open-circuit voltage $U_0$ 230 V AC, short-circuit current $I_k < 1.5$ mA		
<b>On test</b>	On (DUT passive)	$R < 250$ k $\Omega$
	Off (DUT active)	$R > 300$ k $\Omega$
Open-circuit voltage $U_0$ 230 V AC, short-circuit current $I_k < 1.5$ mA		
<b>Probe test</b>	No probe	$R > 2$ M $\Omega$
	Probe detected	$R < 500$ k $\Omega$
<b>Protection class detection</b> (only with country specific variant <sup>1</sup> )		
Protective conductor found: PC I		$R < 1 \Omega$
No protective conductor: PC II		$R > 10 \Omega$
<b>Safety shutdown</b> <sup>1</sup>		
Triggered at following residual current value (selectable)		$> 10$ mA / $> 30$ mA
Triggered at following probe current values		
During leakage current measurement		$> 10$ mA
During protective conductor resistance measurement		$> 250$ mA
<b>Connection test</b> (only with country specific variant <sup>1</sup> )		
Checks whether the DUT is connected to the test socket.		
DUT power cable found		$R < 1 \Omega$
No DUT power cable		$R > 10 \Omega$
<b>Insulation test</b>		
DUT set up in a well-insulated fashion		$R \geq 500$ k $\Omega$
DUT set up in a poorly insulated fashion		$R < 500$ k $\Omega$
PE mains – PE socket: Open-circuit voltage $U_0$ 50 V DC, $I_k < 2$ mA		
<b>Overcurrent protection</b>		
Shutdown in the event of a continuous flow of current via the test socket at: Our <b>SECUTEST BASE(10)/PRO</b> , <b>SECULIFE ST BASE(25)</b> and <b>SECULIFE ST PRO</b> test instruments permit active testing of devices with nominal current (load current) of up to 16 A. The test socket on the respective test instrument is equipped with 16 A fuses to this end, and the switching capacity of the internal relays is also 16 A. Starting current of up to 30 A is permissible. In the case of test objects for which a starting current of greater than 30 A can be expected, we urgently recommend the use of a test adapter for larger starting currents, e.g. a test adapter from the AT3 series.		$I > 16.5$ A

<sup>1</sup> Applies to **M7050** with feature B00 and B09 and B10



### Attention!



#### \* Safety Shutdown

As of 10 mA of differential current (can also be set to 30 mA), automatic shutdown ensues within 500 ms. This automatic shutdown does not take place during leakage current measurement with clamp meter or adapter.

## 7 Notes on Saving Single Measurements and Test Sequences



At the end of each test, test results can be saved under an ID number which is unequivocally assigned to the respective test object (= device or ME equipment (medical electrical equipment)). Depending on the initial situation, i.e. whether or not a test structure or database is already available or an ID has already been entered, the following different procedures are used for saving:

### Variant 1 – preselection of an existing ID

You've already set up a test structure in the test instrument or uploaded one with the help of report generating software. Open the database view before starting the measurement by pressing the **MEM** key. Then select the test object or its ID within the test structure by pressing the respective scroll key. Exit the database view (MEM navigation) by pressing **ESC** and start the measurement. Press the "Save as" key  at the end of the measurement. The display is switched to the SAVE view. The ID appears with a green or orange background. Press the save key  once again in order to complete the procedure.

### Variant 2 – entry of a previously saved ID at the end of the test









You've already set up a test structure in the test instrument or uploaded one with the help of report generating software. You perform the measurement without first opening the database. No test object was previously selected in the database. Press the "Save as" key  at the end of the measurement. The following message appears: "No DUT selected!" Press the **ID** key. The softkey keyboard appears.

If you enter an ID here which is already in the database, the database view appears (MEM navigation) automatically, and the test object's ID is displayed inversely. Acknowledge the entry by pressing the  key. The display is switched to the SAVE view. The ID appears with a green or orange background. Press the save key  once again in order to complete the procedure.

### Variant 3 – entry of a new ID at the end of the test

You haven't yet set up a test structure in the test instrument, or the ID isn't included in the existing structure. Press the save as key  at the end of the measurement. The following message appears: "No test object selected!" Press the **ID** key in order to enter the test object's ID. The softkey keyboard appears.

If you enter an ID here which is **not yet** included in the database, a prompt appears asking you if you want to enter a new test object.



- **Selection **: If you press , the display is switched to the SAVE view. The ID appears with a green or orange background. Press the save key  once again in order to complete the procedure.
- **Selection **: If you press , the display is switched to the database view (MEM navigation). You can go to the next page (Edit Objects 2/3) by pressing , and then enter a new test object. Press  to this end. All possible object types are displayed. Press "Device". The newly entered ID appears in red to the right of the ID parameter. Acknowledge the entry by pressing the  key. The display is switched to the database view (MEM navigation). The newly entered test object is displayed inversely in the structure. Press **ESC** in order to return to the SAVE view. The ID appears with a green background. Press the save key  once again in order to complete the procedure.
- **Selection ESC**: If you don't want to save any measured values, press **ESC** twice in order to go to the measuring view. If you press **ESC** again, a prompt appears asking whether or not you want to delete the measuring points in order to continue with the measurement without saving.

### 7.1 QuickEdit Function – QEDIT (feature KDO1, "Z853S – SECUTEST DB COMFORT")

QuickEdit is available whenever you search for a test object ID which doesn't already exist in the database.

The following search options are available:

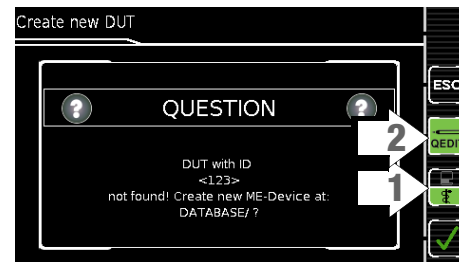

- Via the ID softkey in the test sequence (AutoTest) or in the save menu of the manual test
- ID search via ID softkey on page 3 of 3 of database management MEM
- Read-in of a test object ID via the barcode or RFID scanner

If the searched for ID isn't found, the following question appears. When creating a new object you can first of all choose between a (standard) test object ( icon) or a medical test object – "new ME equipment" (staff of Aesculapius icon ) by pressing the (1) key.

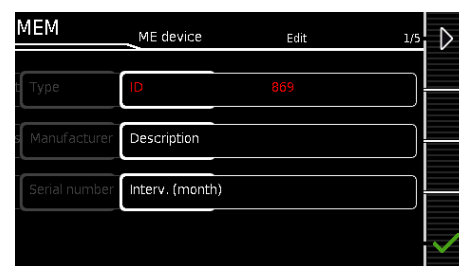

If you select the QEDIT (QuickEdit function) key (2) (shown against a green background and not crossed out), you proceed directly to the memory management entry window by confirming with , in order to create a new test object and enter further properties.



After confirming with , the location of the ID in the database is displayed. Measurement results are saved to memory after pressing the save key  once again.



## 8 Single Measurements

### 8.1 General

- The desired measurement is selected with the help of the green pointer on the rotary switch and the green semicircle.
- The respective measurement is configured with the help of the softkeys. The parameter settings can be accessed by pressing the softkey with the symbol shown at the right.
- The **measurement type** parameter displayed in each case in the footer can be changed directly using the key shown at the right without having to exit the measuring view.
- The selection of **polarity** for line voltage at the test socket can be changed directly using the key shown at the right without having to exit the measuring view.
- No limit values can be specified for single measurements, and thus there's no evaluation.

- Checking is performed before each measurement in order to assure a trouble-free sequence, and to prevent any damage to the DUT.
- Single measurements can be saved to memory. The assignment of an ID number is possible to this end.
- Single measurements can be combined into measurement series.
- Mains power can be connected to the device under test with the desired polarity by making a pre-selection in the parameter settings.

#### Measurement Status – Progress Bar

Measurement standstill (static line)



Measurement in progress (space is gradually filled in, pulsating)

#### Measuring View, Single Measurements

Momentarily measured value

PRINT ESC HELP MEM

Measurement – Start – Stop

PE(Mains) - P1

Offset 1 mΩ

IP(set) ±200 mA =

Measurement/connection type Offset Test current

Select parameters  
Select measurement/connection type  
Adjust test current  
Reset offset to 0 Ω

#### Measuring Parameters Display, Single Measurements

Parameter 1/1

ESC: Discard changes and jump back to measuring view

Mode PE(TS) - P1

IP(set) ±200 mA =

Offset 0 mΩ

Selectable parameter Selected parameter value

Scroll through parameter pages  
Select measuring parameter directly  
Select measuring parameter directly  
Accept changes and jump back to measuring view

#### Numeric Entry (for parameters UIISO(set), Offset ...) via Touchscreen Keyboard with the SECUTEST PRO (feature E01)

0.000

≤ 2.00 Ω  
≥ 0 mΩ  
Unit: Ω

7 8 9  
4 5 6  
1 2 3  
- 0

Delete character to the left of the cursor in the display \*













Accept entry and exit keyboard \*

\* Also via assigned softkey







Figure 7 Configuring Single Measurements (parameters entry and display)



## 8.2 Meaning of Symbols in the User Interface

Symbol	Softkey Variants, Single Measurements
	Set parameters
	Accept changed parameters, acknowledge memory location
	Acknowledge messages during tests/measurements and resume test sequence
	Abort measurement
	Direct selection key for selecting the measurement type
	Currently selected polarity: "L-N" Press key to change polarity
	Currently selected polarity: "N-L" Press key to change polarity
<b>Ip</b>	Direct selection key for selecting test current for protective conductor measurement
	Start evaluation – record measured value. Each time this softkey is pressed, an additional measured value is saved and the number is increased by one.
<b>ID</b>	The ID number to which the measurement(s) will be stored can be entered here.
	Valid measured values have been obtained for a measurement. This measurement can be saved.
	Save measurement data as (with display of directory path / ID or new entry of an ID other than the preselected one)
	1 Transmit measurement data to a PC, e.g. in order to save them to <b>IZYTRONIQ</b> report generating software (push-print function) – refer to <b>IZYTRONIQ</b> online help for a description
	Display measured values from performed measurements
	<b>Magnifying glass icon:</b> show (+) or hide (–) details regarding database objects or selected measurements





## 8.3 Displaying the Last Measured Values

- 1 Start the measurement by pressing the **START/STOP** key . The symbol shown at the right appears and indicates how many measurements have already been performed.
- 2 Stop the measurement by pressing the **START/STOP** key, unless a specified measuring time has been stipulated. . The save symbol (floppy disk with a number 1) appears and indicates that one valid measured value has been recorded, which can now be saved.
- 3 Press the **save symbol** (floppy disk). . "No DUT selected!" appears.
- 4 In order to view the last measured values, press the symbol for executed measurements after testing. The last measured values are displayed. 
- 5 The desired measurement can be selected with the scroll keys. 
- 6 The associated measuring parameters can be shown or hidden using the keys shown at the right. 
- 7 The measured value view is exited by pressing the green checkmark in order to subsequently save the measured values (as described in section 8.4) or to return to the initial view by pressing the ESC key.





## 8.4 Measurement Series and Storage

Single measurements can be combined into measurement series. The measured values can be saved by pressing the save key, or measurement series can be generated. These can be saved to a test object (ID number) which has already been set up in the database (see section 5.4.1). The appearance of the save key changes depending on meaning.

### Measuring Sequence with Pre-Selection of the Test Object

- 1 Activate the database view (MEM navigation) by pressing the **MEM** key.
- 2 Select the test object or its ID number for the following measurements with the scroll keys. 
- 3 Return to the measuring view by pressing the **ESC** key or the **START/STOP** key.
- 4 Start the test with the **START/STOP** key. The symbol shown at the right appears and the zero indicates that no measurements have yet been recorded or saved to buffer memory. 
- 5 Each time the key at the right is pressed, the respective current measured value is saved to buffer memory and the number shown in the icon increased. In this way, you always know how many measurements have already been recorded. 
- 6 Stop the measurement by pressing the **START/STOP** key, unless a specified measuring time has been stipulated. The **Save as** symbol appears (floppy disk icon with the number of measured values saved to buffer memory). 
- 7 If you press the save symbol now (floppy disk), the display is switched to the test object in the database view for checking.
- 8 After pressing the save symbol once again, acknowledgement of successful storage appears. At the same time, the display is switched to the measuring view.

### Measuring Sequence with Subsequent Entry of the Test Object

- 1 Start the measurement by pressing the **START/STOP** key . The symbol shown at the right appears and indicates how many measurements have already been performed.
- 2 Stop the measurement by pressing the **START/STOP** key, unless a specified measuring time has been stipulated. . The save symbol (floppy disk with a number 1) appears and indicates that one valid measured value has been recorded, which can now be saved.
- 3 Press the **save symbol** (floppy disk). 
- 4 You're informed that you haven't selected a test object in the database.
- 5 There are two ways to subsequently select your test object using an ID number which has already been set up in the database:
  - Select the ID number with a **barcode scanner** or
  - Enter an ID number by pressing the **ID** key 
- 6 The cursor jumps to the location of the test object with the selected ID number. You only need to acknowledge this position by pressing the green checkmark.
- 7 Press the save symbol (floppy disk). A message appears indicating that the data have been successfully saved and the display is switched to the measuring view.



### Note

If the entered number cannot be found in the database (because it hasn't been set up), it can be entered immediately by pressing **Yes** when the prompt appears. However, the storage location cannot be selected in this case. The measurement is saved to the most recently selected hierarchy.



**Note**

Measurements and measurement series can only be saved after measurement has been completed. Measured values can only be added to intermediate buffer memory during a measurement. Customer, location and other entries cannot be changed in the memory menu. These have to be selected directly in the database and entered or changed.

---

**Note**

**Please observe the following before storing tests or measurements to the test instrument:**

If applicable, the date of recalibration is printed on test reports, or transmitted to a PC when exporting test data. For this reason we recommend checking the recalibration date saved in the test instrument before starting work with your new test instrument (see page 15).

---

## 8.5 Measuring Protective Conductor Resistance – RPE



### Single measurements, rotary switch level: green

Switch Position	Measurement Type With Mains to Test Socket	Measurement Type Without Mains to Test Socket	Measuring Functions		
			$R_{PE}$ Protective conductor resistance	$I_p$ Test current	
			200 mA	10 A <sup>1</sup>	25 A <sup>1</sup>
$R_{PE}$		Passive: PE(TS) - P1	•	•	•
		Active: PE(TS) - P1 <sup>4</sup>	•	•	•
		PE(mains) - P1	•	•	•
		PE(mains) - P1 clamp <sup>3</sup>		•	
		P1 - P2 <sup>2</sup>	•	•	•

<sup>1</sup> 10/25 A RPE measurements are only possible with line voltages of 115/230 V and line frequencies of 50/60 Hz.

<sup>2</sup> Connection for 2<sup>nd</sup> test probe for 2-pole measurement (instrument with feature H01)

<sup>3</sup> Only instruments with feature G01

<sup>4</sup> Can only be selected if the IP(set) parameter has been set to 200 mA.

### Application, Definition, Measuring Method

Protective conductor resistance is the sum of the following resistances:

- Connector cable or device connector cable resistance
- Contact resistance at plug and terminal connections
- Extension cord resistance if applicable

### Protection Class I Devices

- Measurement type PE(TS) - P1 (passive)
- DUT mains plug to test socket
- Test probe P1 to P1 terminals

### Schematic Diagram

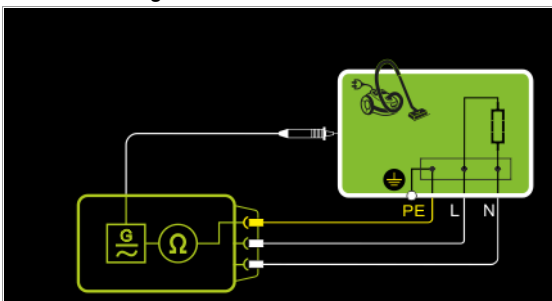

Protective conductor resistance is measured between the earthing contacts at the mains plug and the earthing contact connected to the housing by contacting the housing with test probe P1.

### Wiring Diagram

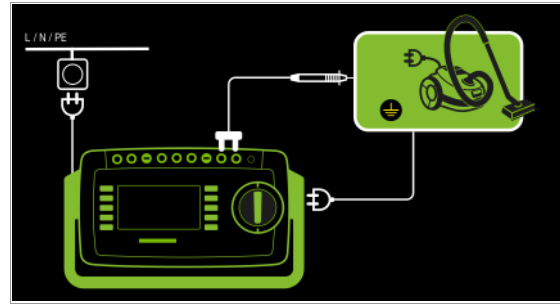

### Measurement of RPE at Single-Phase Extension Cords with EL1

- Measurement type PE(TS) - P1 (passive)
- Extension cord plug to test socket
- EL1 to P1 terminals

### Schematic Diagram

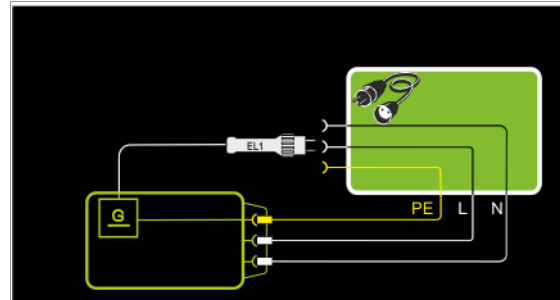

### Wiring Diagram

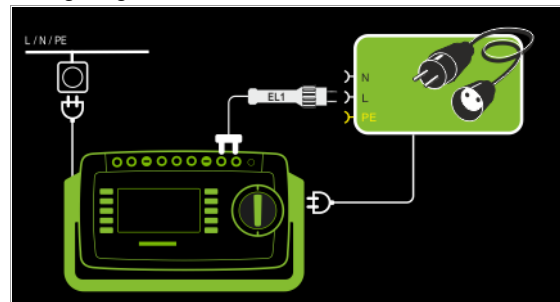

### Protection Class I Devices

#### Special Case: Line Voltage at Test Socket (for testing PRCDs)

- Measurement type PE(TS) - P1 (active)
- DUT mains plug to test socket
- Test probe P1 to P1 terminals

### Schematic Diagram

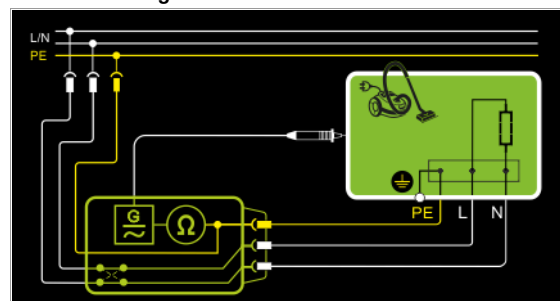

Protective conductor resistance is measured between the earthing contacts at the mains plug and the earthing contact connected to the housing by contacting the housing with test probe P1.

## Wiring Diagram

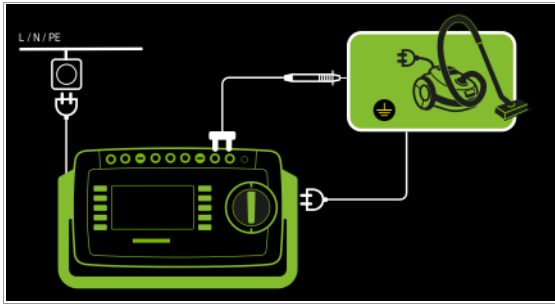

## Protection Class I Devices

### Special Case: Permanently Installed DUTs

- Measurement type PE(mains) - P1
- Test probe P1 to P1 terminals

## Schematic Diagram

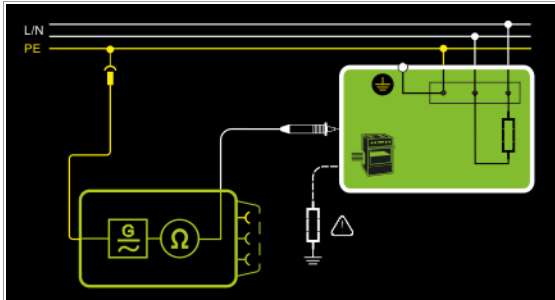

In the case of *permanently installed DUTs*, protective conductor resistance is measured between the mains power earthing contact and the earthing contact connected to the housing by contacting the housing with test probe P1.

## Wiring Diagram

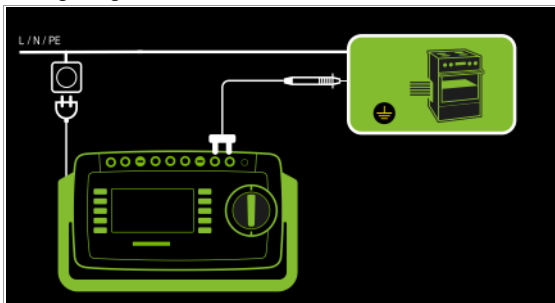

## Measurement via Current Clamp Sensor at Permanently Installed DUTs

- Measurement type PE(mains) - P1 clamp
- Test probe P1 to P1 terminals
- Clamp to COM-V (only feature IO1 with optional current clamp sensor)

## Schematic Diagram

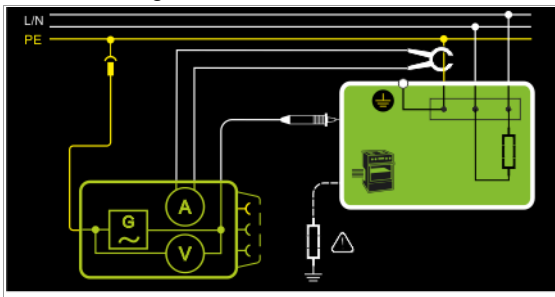

Measurement of test current by closing the current clamp sensor around mains PE and contacting the housing with test probe P1 for permanently installed protection class I devices under test

## Wiring Diagram

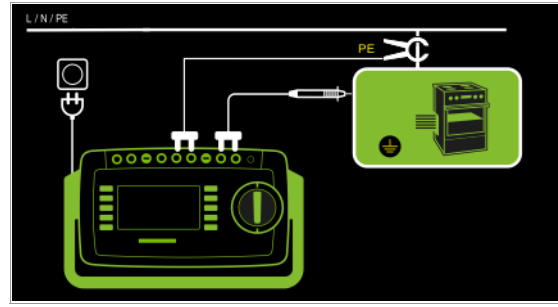

## Setting Measuring Range at the Clamp and Parameters at the Test Instrument

This measurement type can only be selected if test current is set to 10 A AC.

Test Instrument	Clamp		Test Instrument
Parameter: Transformation Ratio	Transformation Ratio (switch *)	Measuring Range	Display Range with Clamp
1 mV : 1 mA	WZ12C		0 mA ... 300 A
	1 mV : 1 mA	1 mA ... 15 A	

\* Only with WZ12C

## 2-Pole Measurement at Permanently Installed DUTs (feature H01)

- Measurement type P1 - P2
- Test probe P1 to P1 terminals
- Test probe P2 to P2 terminals

## Schematic Diagram

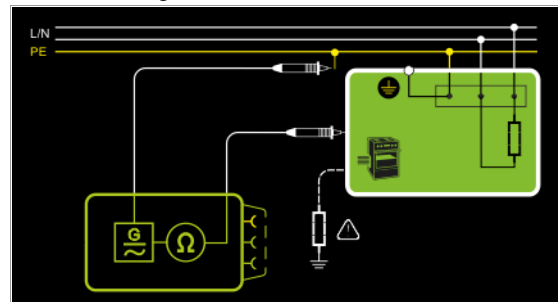

PE at the mains connection is contacted with the second test probe instead of via the test instrument's mains plug.

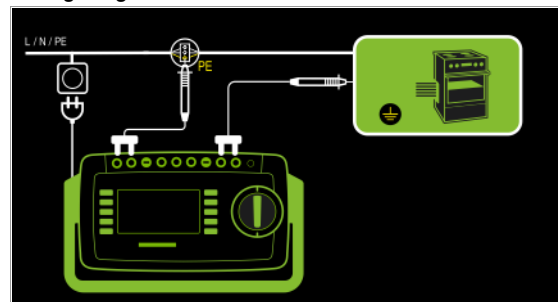

## Wiring Diagram



## Resistance is measured:

- Between each exposed *conductive part of the housing* and the earthing contacts at the mains and the device plug (if a removable mains connector cable is used), or the protective conductor terminal for permanently installed devices.
- As 4-pole measurement
- Between the earthing contacts at the mains plug and the earthing contacts at the device plug for *device connector cables*
- Between the earthing contacts at the mains plug and the earthing contacts at the coupling socket for *extension cords*



Measuring Parameter	Meaning	
<b>Measurement Type</b>		 <b>Suitable for DUT Connection via</b>
<b>(passive:) PE(TS) – P1</b>	Testing is conducted between the two protective conductor terminals: at the test socket and test probe P1.	Test socket, EL1 with DUT at test socket, VL2E, AT3 adapter (AT3-IIE, AT3-IIS, AT3-IIS32), AT16DI/AT32DI
<b>Active: PE(TS) – P1 (TS on)<sup>1</sup></b>	Same as <b>PE(TS) – P1</b> , but with line voltage to the test socket, 200 mA AC flows immediately. A ramp-like, slowly rising DC test current flows (PRCD triggering is avoided) at +200 mA DC, -200 mA DC and ±200 mA DC.	Test socket (for PRCDs)
<b>PE(mains) – P1<sup>1</sup></b> <i>Permanently connected DUTs</i>	Testing is conducted between the ground terminal at the mains and test probe P1.	Permanent connection
<b>PE(mains) – P1 clamp<sup>2</sup></b>	(features G01 and IO1): Test current measurement with current clamp sensor	Permanent connection
<b>P1 – P2</b>	(feature H01): 2-pole measurement between test probes 1 and 2 (see section 6.6)	Permanent connection
<b>IP(set)</b>		
<b>+200 mA DC</b>	Test current: positive direct current	
<b>-200 mA DC</b>	Test current: negative direct current	
<b>±200 mA (DC)</b>	Test current: direct current whose polarity is reversed every 2 seconds	
<b>200 mA (AC)</b>	Test current: alternating current, adjustable frequency f, see below	
<b>10 A (AC)</b>	10 A test current (feature G01)	
<b>25 A (AC)</b>	25 A test current (feature G02)	
<b>f – only at 200 mA (AC)</b>		
<b>50 ... 200 Hz</b>	Test frequency (adjustable in steps: 50, 60, 110, 150, 200 Hz)	
<b>Offset</b>		
<b>&gt; 0 ... &lt; 5 Ω</b>	Zero balancing for a selected reference point.	
<b>Polarity</b>		 Only with measurement type PE(TS) – P1 (TS on)
<b>L/N or N/L</b>	Selection of polarity for mains voltage to the test socket	
<b>Clamp factor – only for clamp measurement type</b>		
<b>1 mV : 1 mA</b>	Transformation ratio of the <b>WZ12C</b> current clamp sensor. For setting the current clamp factor at the <b>WZ12C</b> clamp and the test instrument (see table above).	

<sup>1</sup> Measurement cannot be performed with 10/25 A AC for this measurement type.

<sup>2</sup> Feature G01: This type of measurement can only be selected if a test current of 10 A AC has been chosen.

## Entering and Deleting Offset Values

The test instrument determines protective conductor resistance by means of a 4-pole measurement. If measurement cables or extension cords are used whose ohmic resistance should be automatically subtracted from the measurement results, there are two ways to save the respective offset value in the  $R_{PE}$  switch position:

- Entry via the numeric keypad
- Acceptance of the momentary measured value by pressing the **SET OFFSET** softkey

Proceed as follows in order to accept the measured value:

- ◇ Start the measurement and wait until the measured value settles in.
- ◇ Press the **SET OFFSET** key. The value is transferred to the offset field.

The entered or accepted offset value is permanently stored and is subtracted from all protective conductor resistance values measured in the future. This applies to single measurements as well as to measurements conducted in the AUTO switch positions. The  symbol is displayed in the header in all switch positions until the offset value is deleted by pressing the **CLEAR OFFSET** softkey ( $R_{PE}$  switch position).

## Protective Conductor Measurement with 25 A AC (feature G02)

In accordance with IEC 60601, at least 25 A must be achieved with a load of 0.1 Ω and a maximum voltage of 0.6 V.

Continuous protective conductor resistance measurement with a test current of 25 A isn't possible due to contact resistance at the jacks.

If the test instrument is operated at room temperature, an uninterrupted **test duration of at least 15 seconds** is possible. Under other conditions, maximum test duration may be shorter and/or the measurement may be prematurely terminated.



### Attention!

Suitable measurement cables with a minimum wire cross-section of 2.5 mm must be used when measuring protective conductor resistances with a "25 A AC" test current.

Included: suitable test probe with **green** strain relief sleeve.

For subsequent orders, we recommend the SK2-25A test probe (Z746C).

Under certain circumstances, the required standard values might not be complied with if unsuitable accessories are used.



### Attention!

Measurement duration with a 25 A test current is limited (see technical data).

An error message is generated if measurement duration is exceeded which results in a temperature increase at the test instrument.

### Test Sequence with Connection to the Test Socket

- ⇨ Set the rotary switch to the **R<sub>PE</sub>** position.
- ⇨ Select measurement type or connection type, as well as test current. After pressing the **Ip** key, you have direct access to the test current parameters: each time this key is pressed, the setpoint value shown in the measuring window is switched to the next value.
- ⇨ Connect the DUT to the test socket.
- ⇨ **Start the test:** press the **START/STOP** key.



- ⇨ Contact all conductive parts which are connected to the protective conductor with test probe P1.

During measurement, the **connector cable** must only be moved to the extent to which it's accessible during repair, modification or testing.

If a change in resistance occurs during the manual test step of the continuity test, it must be assumed that the protective conductor is damaged, or that one of the connector contacts is no longer in flawless condition.

- ⇨ The measured values are displayed. The measured value recording symbol shown at the right appears. Each time this key is pressed, the currently displayed measured value is saved to buffer memory.



- ⇨ **End the test:** press the **START/STOP** key. The save symbol appears (floppy disk showing the number of measured values stored to buffer memory) and prompts you to save the measured values to an ID number.



- ⇨ Read the measured values and compare them with the table of permissible limit values.
- ⇨ Press the **ESC** key in order to discard the measured values stored to buffer memory and acknowledge by pressing the key shown at the right.



### Special Case: Testing Extension Cords

- ⇨ Set the measurement type parameter to "PE(TS) – P1".
- ⇨ Connect the EL1 adapter to the P1 sockets at the test instrument.
- ⇨ Connect the plug at the end of the extension cord to the test socket.
- ⇨ Connect the coupling socket at the end of the extension cord to the plug at the EL1 adapter.
- ⇨ The test sequence is the same as described above.

Further options for testing extension cords are included in the description of the single measurement in the **EL1** switch position and under automatic test sequences in switch position A8.

### Special Case: Permanently Installed DUT

- ⇨ Contact the conductive parts of the housing with test probe P1.

### Special Case: Testing Protective Conductor Resistance at PRCDs

For PRCDs whose protective conductor resistance cannot be measured when switched off, the test instrument offers the "active: PE(TS) - P1" measurement type, with which the PRCD can be switched on in order to ascertain protective conductor resistance.

- ⇨ Set the measurement type parameter to "active: PE(TS) – P1 (TS on)".
- ⇨ Connect the EL1 adapter (or alternatively a standard test probe) to the P1 sockets at the test instrument.
- ⇨ Connect the plug of the PRCD under test to the test socket.
- ⇨ Connect the EL1 adapter to the outlet on the PRCD (alternative: connect the test probe to the protective conductor of the PRCD's outlet, e.g. by means of an alligator clip).
- ⇨ Start the measurement.
- ⇨ Switch line voltage to the test socket. Then switch the PRCD on.
- ⇨ Otherwise, the test sequence is the same as described above.



#### Note

With the +200 mA=, -200 mA= and ±200 mA= measurement types, test current rises very slowly in order to prevent triggering of residual current monitoring at the PRCD. And thus with this measurement type, it may take longer than usual until a valid measured value is displayed. For this reason, the protective conductor should not be contacted manually with the test probe, in order to prevent a sudden rise in test current resulting in inadvertent tripping of the PRCD.

### Maximum Permissible Limit Values for Protective Conductor Resistance for Connector Cables with Cross-Sections of up to 1.5 sq. mm and Lengths of up to 5 m

Test Standard	Test Current	Open-Circuit Voltage	R <sub>PE</sub> Housing – Device Plug	R <sub>PE</sub> Housing – Mains Plug	Mains Cable
VDE 0701-0702:2008 DIN EN 60974-4 VDE 0544-4:2009-06	> 200 mA=	4 V < U <sub>L</sub> < 24 V		0.3 Ω + 0,1 Ω <sup>1</sup> for each additional 7.5 m	
IEC 62353 (VDE 0751-1)	> 200 mA=		0.2 Ω	0.3 Ω	0.1 Ω
EN 60601	> 200 mA=		0.1 Ω	0.2 Ω	

<sup>1</sup> Total protective conductor resistance: max. 1 Ω

## 8.6 Insulation Resistance Measurement – RINS

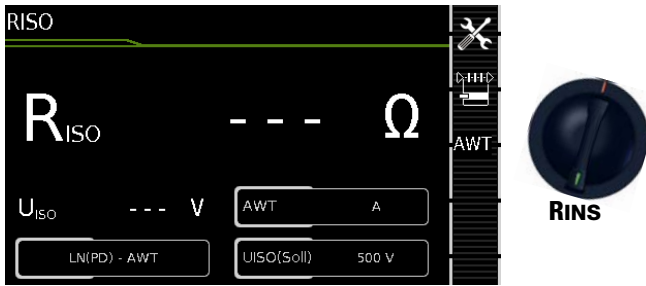

Single measurements, rotary switch level: green		
Switch Position	Measuring Functions	Measurement Type Without Mains to Test Socket
R <sub>INS</sub>	R <sub>INS</sub> Insulation resistance (PC I/PC II)	LN(TS) - PE(TS) LN(TS) - P1 P1 - P2 <sup>1</sup> PE(mains) - P1 PE(TS) - P1 LN(TS) - P1//PE(TS) LN(TS) - APP PE(mains) - APP PE(TS) - APP P1//PE(TS) - APP P2 - APP
	U <sub>INS</sub> Test voltage	

<sup>1</sup> Connection for 2<sup>nd</sup> test probe for 2-pole measurement (feature H01)

### Application, Definition, Measuring Method

#### Protection Class I Devices

- Measurement type LN(TS) - PE(TS)
- DUT mains plug to test socket

#### Schematic Diagram

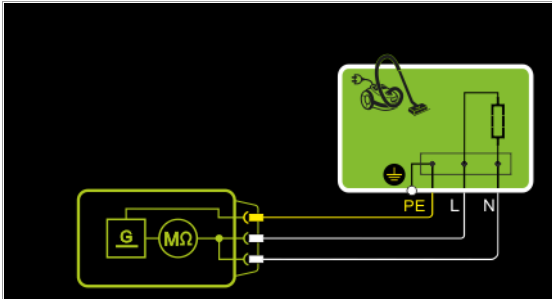

Insulation resistance is measured between short-circuited mains terminals (L-N) and protective conductor PE.

#### Wiring Diagram

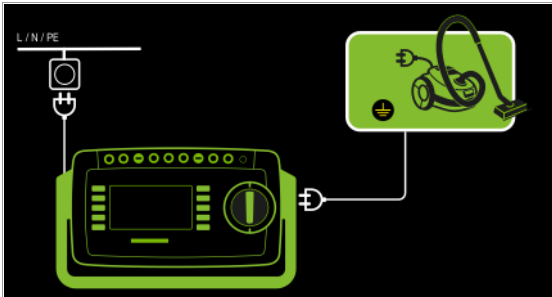

#### Protection Class II Devices

- with Exposed Conductive Parts
- Measurement type LN(TS) - P1
- DUT mains plug to test socket
- Test probe P1 to P1 terminals

#### Schematic Diagram

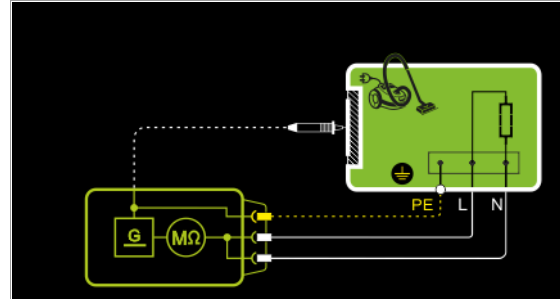

Insulation resistance is measured between short-circuited mains terminals (L-N) and external conductive parts which can be contacted with test probe P1 and are **not** connected to the housing.

#### Wiring Diagram

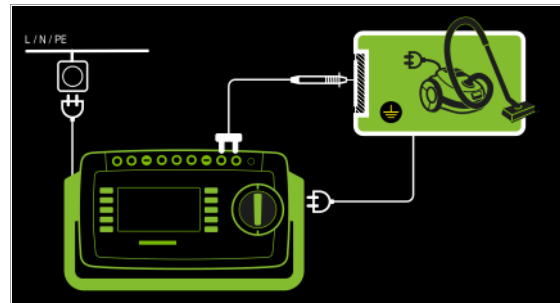

#### Protection Class II Devices with Outputs for Safety Extra-Low Voltage

- Measurement type LN(TS) - P1
- DUT mains plug to test socket
- Test probe P1 to P1 terminals

#### Schematic Diagram

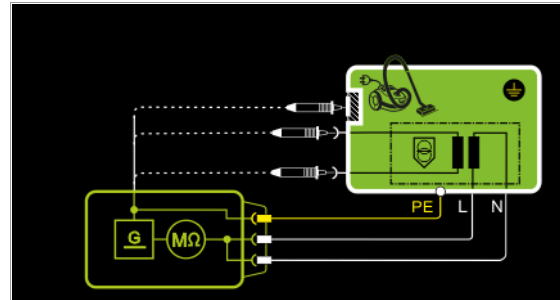

Insulation resistance is measured between short-circuited mains terminals (L-N) and the safety extra-low voltage outputs which are contacted with probe P1.

#### Wiring Diagram

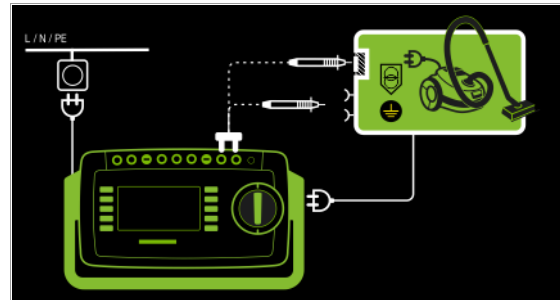

## Protection Class I Devices with Outputs for Safety Extra-Low Voltage and Exposed Conductive Parts

- Measurement type LN(TS) - P1
- DUT mains plug to test socket
- Test probe P1 to P1 terminals

### Schematic Diagram

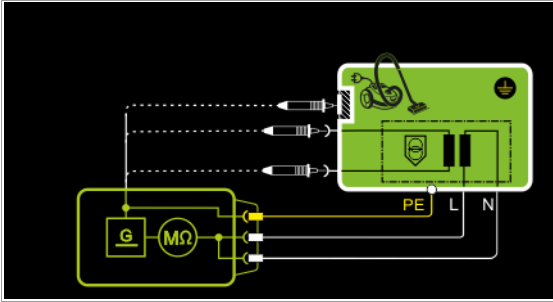

Insulation resistance is measured successively between short-circuited mains terminals (L-N) and the safety extra-low voltage outputs which can be contacted with test probe P1, as well as external conductive parts which are **not** connected to the housing.

If measuring points should be contacted one after the other, this is indicated by a dashed line. However, there are two parallel measuring circuits for the RISO measurement with the LN(TS) – P1//PE(TS) measuring parameter, which are established simultaneously to the short-circuited L and N conductors: one insulation resistance is measured via PE at the test socket and, at the same time, a second insulation resistance is measured via test probe P1.

### Wiring Diagram

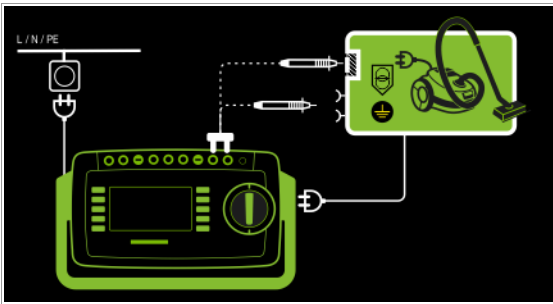

## 2-Pole Measurement at Protection Class I Housing Parts (feature H01)

- Measurement type P1 - P2

### Schematic Diagram

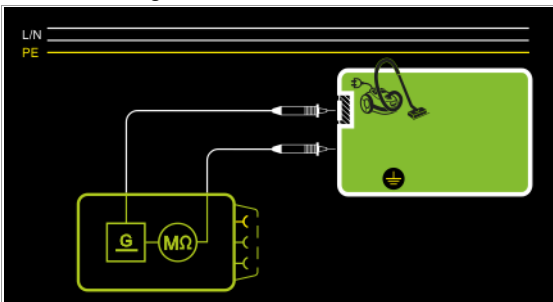

Insulation resistance is measured between external conductive parts which can be contacted from the outside with test probe P2 and are **not** connected to the housing, and the housing with test probe P1.

## Wiring Diagram

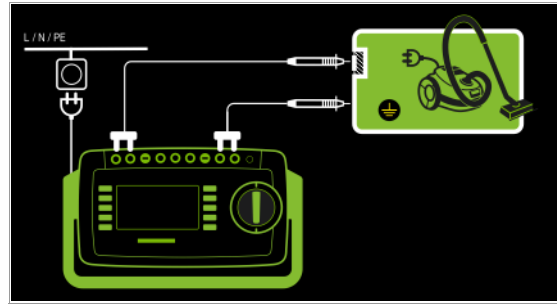

## Special Case: Permanently Installed Protection Class I Devices

- Measurement type PE(mains) - P1
- Test probe P1 to P1 terminals

### Schematic Diagram

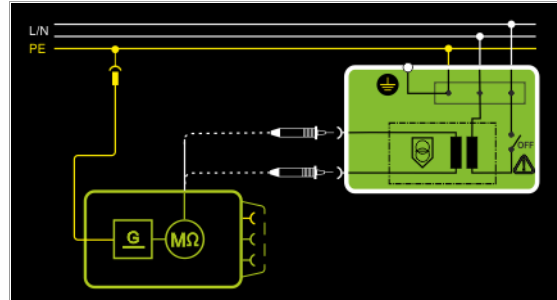

Insulation resistance is measured successively between PE at the mains connection and the extra-low voltage inputs by contacting each of them with test probe P1.

### Wiring Diagram

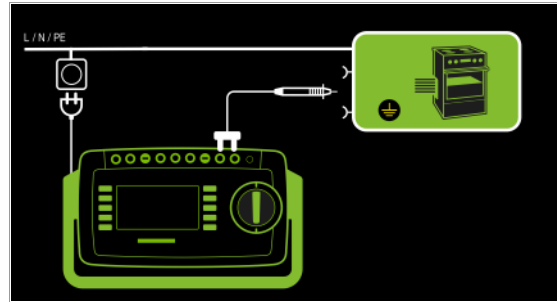

### Attention!

Deactivate the electrical system which supplies power to the device under test before connecting the test instrument!

- ⇒ Remove the mains fuses from the device under test and disconnect neutral conductor N inside the device under test.
- ⇒ Connect test probe P1 to phase conductor L at the device under test in order to measure insulation resistance.



- Protection Class I Devices with Terminals for Applied Parts**  
 – Measurement type PE(TS) - P1  
 – DUT mains plug to test socket  
 – Test probe P1 to P1 terminals

**Schematic Diagram**

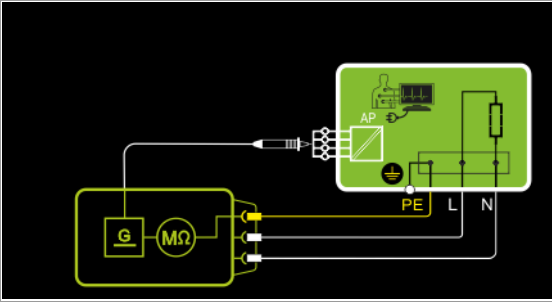

Insulation resistance is measured between protective conductor terminal PE and external, short-circuited applied parts which can be contacted with test probe P1.

**Wiring Diagram**

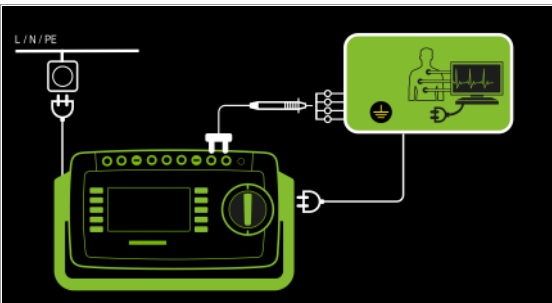

- Protection Class I Devices with Exposed Conductive Parts**  
 – Measurement type LN(TS) - P1//PE(TS)  
 – DUT mains plug to test socket  
 – Test probe P1 to P1 terminals

**Schematic Diagram**

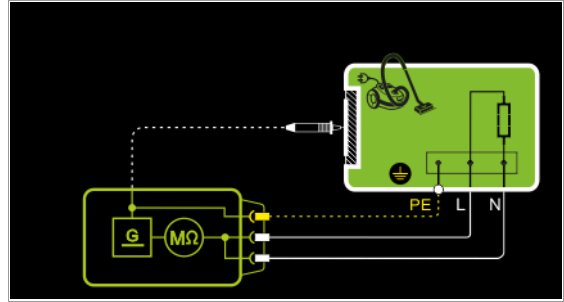

Insulation resistance is measured between short-circuited mains terminals (L-N) and external conductive parts which can be contacted with test probe P1 and are **not** connected to the housing, as well as protective conductor terminal PE at the housing.

**Wiring Diagram**

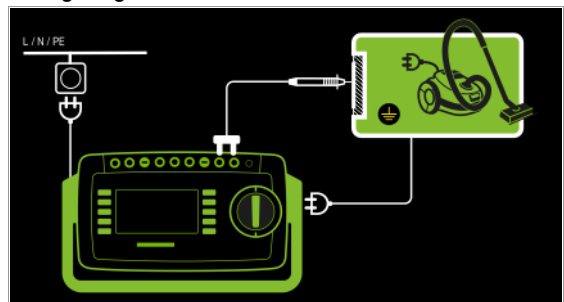

- Protection Class I Devices with Outputs for Safety Extra-Low Voltage**  
 – Measurement type PE(TS) - P1  
 – DUT mains plug to test socket  
 – Test probe P1 to P1 terminals

**Schematic Diagram**

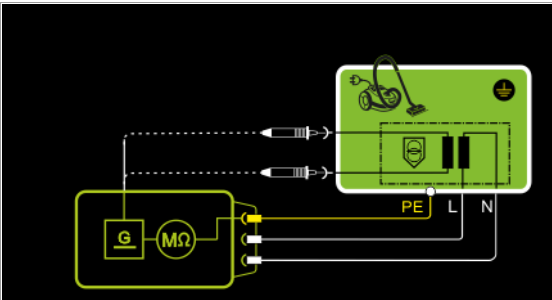

Insulation resistance is measured between the PE terminal and the safety extra-low voltage outputs, which must be contacted one after the other with probe P1.

**Wiring Diagram**

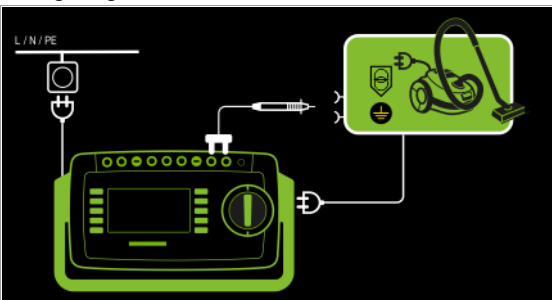

- Protection Class I Devices with Terminals for Applied Parts**  
 – Measurement type LN(TS) - APP  
 – DUT mains plug to test socket  
 – APP to APP socket(s)

**Schematic Diagram**

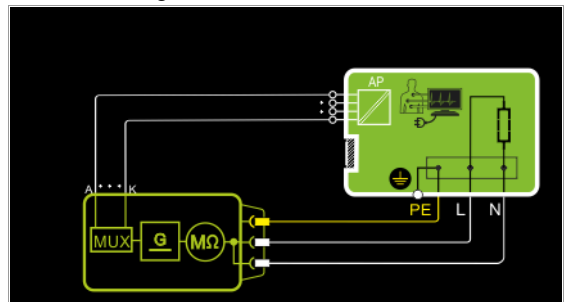

**Wiring Diagram**

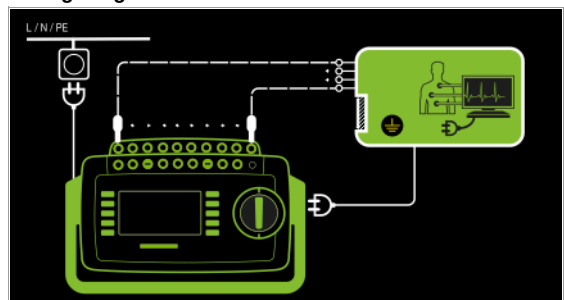

- Protection Class I Devices  
with Terminals for Applied Parts
- Measurement type PE(mains) - APP
  - DUT mains plug to test socket
  - APP to APP socket(s)

Schematic Diagram

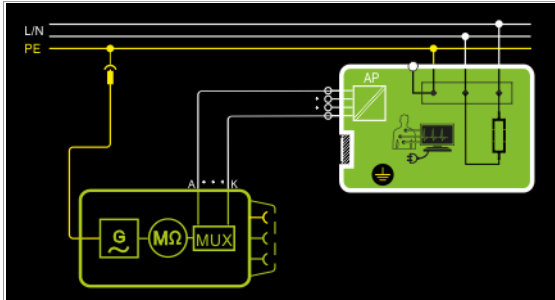

Wiring Diagram

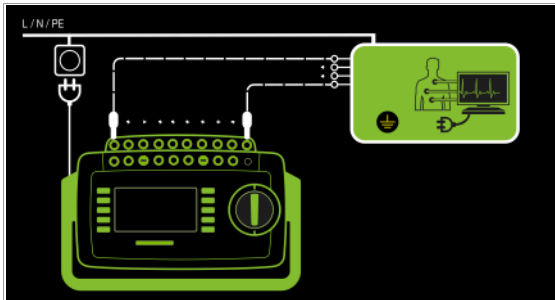

- Protection Class I Devices  
with Terminals for Applied Parts
- Measurement type P1 // PE(TS) - APP
  - DUT mains plug to test socket
  - APP to APP socket(s)

Schematic Diagram

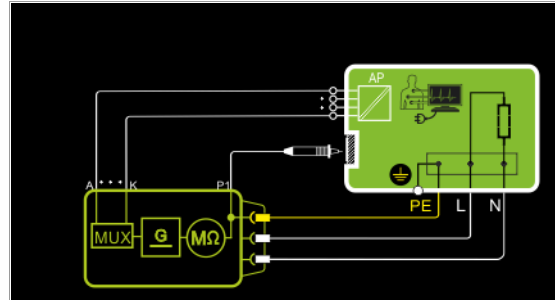

Wiring Diagram

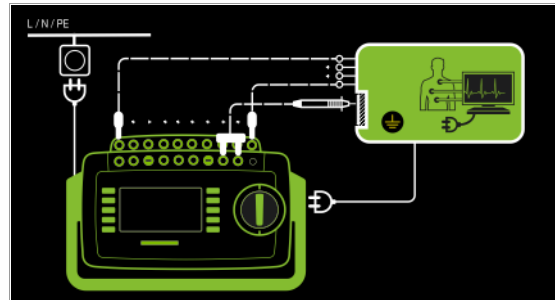

- Protection Class I Devices  
with Terminals for Applied Parts
- Measurement type PE(TS) - APP
  - DUT mains plug to test socket
  - APP to APP socket(s)

Schematic Diagram

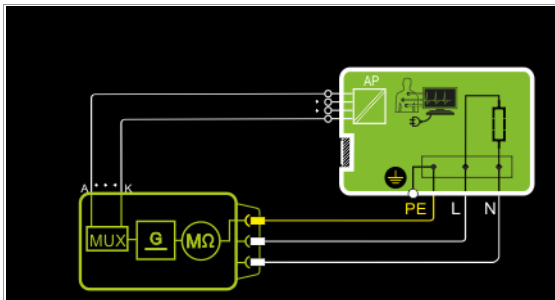

Wiring Diagram

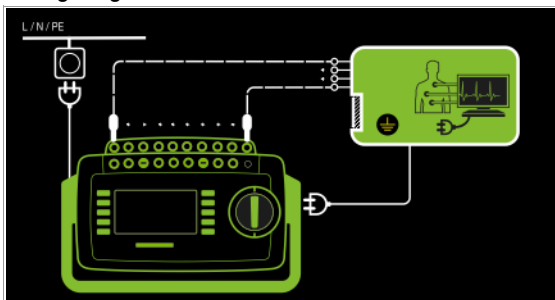

- Protection Class I Devices  
with Terminals for Applied Parts
- Measurement type P2 - APP
  - DUT mains plug to test socket
  - APP to APP socket(s)

Schematic Diagram

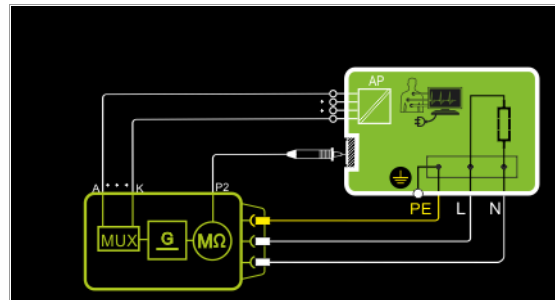

Wiring Diagram

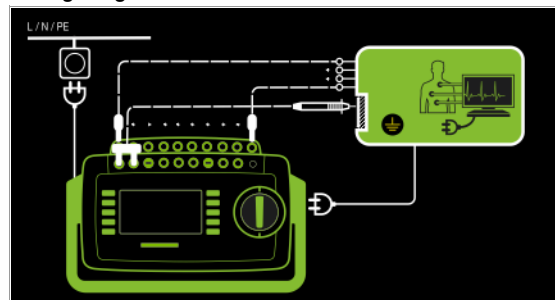



Measuring Parameter	Meaning	
<b>Measurement Type</b>		 <b>Suitable for DUT Connection via</b>
<b>LN(TS)-PE(TS)</b>	PC I: Testing is conducted between short-circuited LN mains terminals at the test socket and the DUT's PE terminal.	Test socket, EL1, VL2E, AT3 adapter (AT3-III E, AT3-IIS, AT3-IIS32), AT16DI/AT32DI, CEE Adapter
<b>LN(TS)-P1</b>	Testing is conducted between short-circuited LN mains terminals at the test socket and test probe P1.	Test socket, VL2E, AT3 adapter (AT3-III E, AT3-IIS, AT3-IIS32), AT16DI/AT32DI,
<b>P1 – P2</b>	2-pole measurement between test probes 1 and 2 (see section 6.6)	No connection (PC3)
<b>PE(mains)-P1</b>	Cable test: Testing is conducted between the ground terminal at the mains and test probe P1.	Permanent connection
<b>PE(TS)-P1</b>	Testing is conducted between the PE terminal at the test socket and test probe P1.	Test socket
<b>LN(TS)-P1 // PE(TS)</b>	Testing is conducted between short-circuited LN mains terminals at the test socket and test probe P1, including PE at the test socket.	Test socket, VL2E, AT3 adapter (AT3-III E, AT3-IIS, AT3-IIS32), AT16DI/AT32DI,
<b>LN(TS) – APP</b>	Testing is conducted between LN(TS) and selected APP sockets.	Test socket, VL2E, AT3 adapter (AT3-III E, AT3-IIS, AT3-IIS32), AT16DI/AT32DI,
<b>PE(mains) – APP</b>	Testing is conducted between PE(mains) and selected APP sockets.	Permanent connection
<b>PE(TS) – APP</b>	Testing is conducted between PE(test socket) and selected APP sockets.	Test socket, VL2E, AT3 adapter (AT3-III E, AT3-IIS, AT3-IIS32), AT16DI/AT32DI,
<b>P1 // PE(TS) – APP</b>		Permanent connection
<b>P2 – APP</b>	Testing is conducted between probe P2 and selected APP sockets.	
<b>APP – applied parts</b>		
Individual selection: A / B / C / D / E / F / G / H / I / K, respectively via on/off		
<b>UIISO(set)</b>		
<b>&gt; 50 ... &lt; 500 V</b>	Variable test voltage can be entered with the numeric keypad	

**Attention!**
**Prerequisite for Testing**

The measurement of insulation resistance may not be conducted on protection class I devices which have not passed the protective conductor resistance test.

**Note**

The insulation test cannot be performed for all DUTs, for example electronic devices, EDP equipment, medical devices etc. Leakage current measurements must be performed for these DUTs (see section 8.7). Observe the notes in the service instructions.

**Attention!**

In order to prevent damage to the instrument, measurement of insulation resistance may only be performed between applied parts, measurement inputs or interfaces and the protective conductor or the housing if the instrument is laid out for measurements of this type.

**Attention!**
**Touching the DUT During Measurement**

Testing is conducted with up to 500 V, and although current is limited ( $I < 3.5 \text{ mA}$ ), if the DUT is touched electrical shock may occur which could result in consequential accidents.

**Attention!**
**Switch Settings at the DUT**

All switches at the DUT must be set to the on position during measurement of insulation resistance, including temperature controlled switches and temperature regulators as well.

Measurement must be performed in all program steps for devices equipped with program controllers.

⇒ Set the rotary switch to the **R<sub>INS</sub>** position.

⇒ Select the measurement type:

– By setting the parameters

or

– Directly via the **Measurement Type** key 

⇒ In the case of measurement type APP:

Additionally select the respective applied parts by setting the utilized sockets to “on” and the unused sockets to “off”.



⇒ Connect the DUT to the test socket.

⇒ In the case of measurement type APP: Connect the applied parts.

⇒ **Start the test:** press the **START/STOP** key.



⇒ Switch the device under test on.

**Note**

The measurement is disabled if a voltage of greater than 25 V is measured between the terminals.

⇒ The measured values are displayed. The measured value recording symbol shown at the right appears. Each time this key is pressed, the currently displayed measured value is saved to buffer memory.



⇒ Turn off the device under test.



### Attention!

#### Removing the Connector Cable

Do not remove the DUT's connector cable until the test has been stopped, in order to assure that the capacitors have been discharged.

- End the test: press the **START/STOP** key.

The save symbol appears (floppy disk showing the number of measured values stored to buffer memory) and prompts you to save the measured values to an ID number.



- Read the measured values and compare them with the table of permissible limit values.
- Press the **ESC** key in order to discard the measured values stored to buffer memory and acknowledge by pressing the key shown at the right.



### Minimum Permissible Limit Values for Insulation Resistance

Test Standard	Test voltage	R <sub>INS</sub>				
		LN → PE	LN → Probe	Probe → PE	PC III	Heating
VDE 0701-0702:2008	500 V	1 MΩ	2 MΩ	5 MΩ	0.25 MΩ	0.3 MΩ *
DIN EN 60974-4 VDE 0544-4:2009-06		2 MΩ	5 MΩ	5 MΩ		

\* With activated heating elements (where heating power > 3.5 kW and R<sub>INS</sub> < 0.3 MΩ: leakage current measurement is required)

Test Standard	Test voltage	R <sub>INS</sub>	
		PC I	PC II
IEC 62353 (VDE 0751-1)	500 V	2 MΩ	7 MΩ
		BF or CF 70 MΩ	BF or CF 70 MΩ

### Notes

Insulation resistance and/or leakage current must be measured for protection class II and III devices, as well as for battery powered devices, by contacting all exposed, conductive parts with test probe P1.

Batteries must be disconnected during testing of battery powered devices.

## 8.7 Measuring Leakage Current



### Attention!

#### Measurement with DUT Connected to Line Voltage

It's absolutely essential to assure that the device under test is operated with line voltage during performance of **leakage current measurements with the direct or differential current method**. Exposed conductive parts may conduct dangerous touch voltage during testing, and may not under any circumstances be touched. (Mains power is disconnected if leakage current exceeds approx. 10 mA.)

Frequency response in accordance with the figure to the right is taken into consideration for all leakage current measurements (IPE, IT, IE, IA, IP, IPA) (direct, differential, alternative).

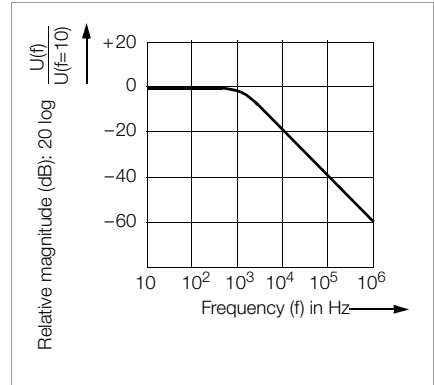

## 8.7.1 Protective Conductor Current – IPE

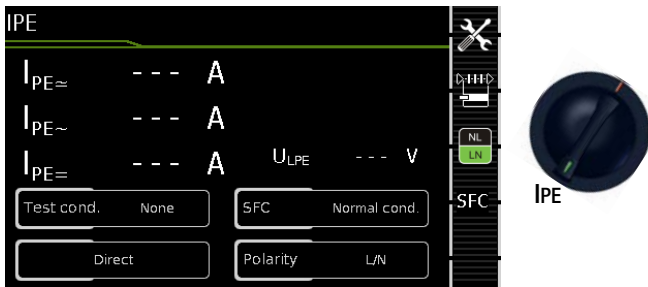

Single measurements, rotary switch level: green			
Switch Position	Measurement Type With Mains to Test Socket	Measurement Type Without Mains to Test Socket	Measuring Functions
IPE	Direct		$I_{PE\approx}$ Protective conductor current, RMS $I_{PE\sim}$ AC component $I_{PE=}$ DC component $U_{LN}$ Test voltage
		Differential	$I_{PE\approx}$ Protective conductor current, RMS $U_{LN}$ Test voltage
		Alternative	$I_{PE\approx}$ Protective conductor current, RMS $U_{\sim}$ Test voltage
	AT3 adapter <sup>1</sup>		$I_{PE\approx}$ Protective conductor current, RMS $U_{LN}$ Test voltage
		Clamp <sup>2</sup>	$I_{PE\approx}$ Protective conductor current, RMS $U_{LN}$ Test voltage

- <sup>1</sup> Adapter AT3-III, AT3-IIS or AT3-II S32:  
Voltage measuring inputs for leakage current measurement with differential method (instrument with feature I01)
- <sup>2</sup> Voltage measuring inputs for leakage current measurement with differential method and use of a current clamp sensor with (instrument with feature I01)

### Applications

Protective conductor current must be measured for protection class I devices.

### Definition of Protective Conductor Current (direct measurement)

Current which flows through the protective conductor in the case of housings which are isolated from ground.

### Definition of Differential Current

Sum of instantaneous current values which flow via the L and N conductors at the device's mains connection. Differential current is practically identical to fault current in the event of an error. Fault current: current which is caused by an insulation defect, and which flows via the defective point.

### Definition of Alternative Measuring Method (equivalent leakage current)

Equivalent leakage current is current which flows through the device's active conductors, which are connected to each other (L/N), to the protective conductor (SC1) or to the exposed, conductive parts (SC2).

### Differential Current Measuring Method

The device under test is operated with mains power. The sum of the momentary values of all current which flows through all active conductors (L/N) at the mains side of the device connection is measured. The measurements must be performed with mains plug polarity in both directions.

### Alternative Measuring Method (equivalent leakage current)

A high-impedance power supply is connected between the short-circuited mains terminals and all exposed metal parts of the hous-

ing (which are connected to each other). Current which flows over the insulation at the device under test is measured.

### Protective Conductor Current Measuring Method (direct measurement)

The device under test is operated with mains power. Current which flows through the PE conductor to earth at the mains side of the device connection is measured.



#### Note

Regardless of the currently selected connection type, all help images and schematic diagrams can be queried for the selected measuring function.

### Direct Measuring Method

- *Direct measurement type*
- DUT mains plug to test socket
- APPs to APP sockets

### Schematic Diagram

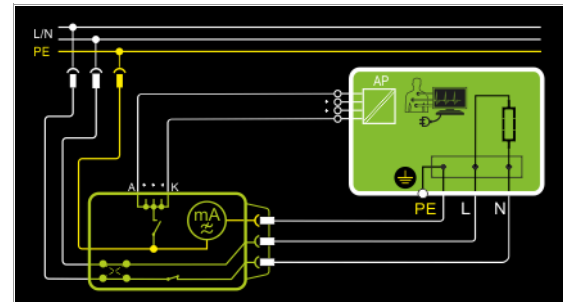

The device under test is operated with mains power. Protective conductor current is measured between the protective conductor at the mains and the protective conductor terminal at the DUT via the DUT's mains cable.

The special case involving "all APP sockets connected to PE potential" can be selected.

### Wiring Diagram

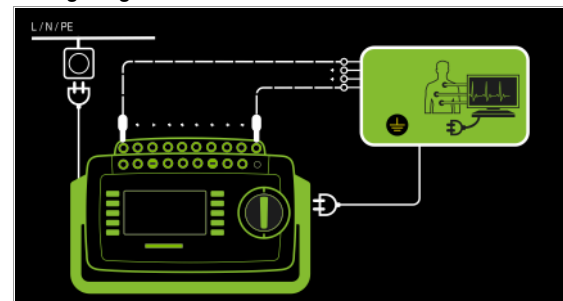

### Differential Current Measurement

- *Differential measurement type*
- DUT mains plug to test socket

### Schematic Diagram

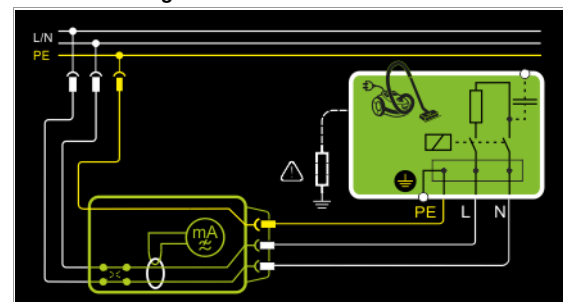

The device under test is operated with mains power. Differential current is measured between mains conductors L and N (current clip concept).

## Wiring Diagram

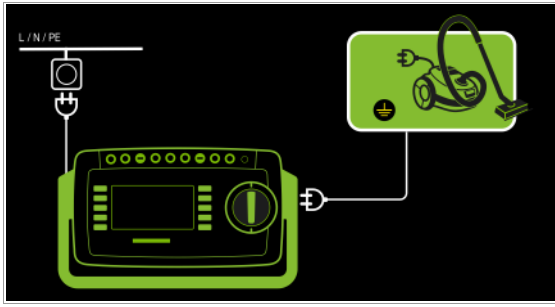

## Wiring Diagram (AT3-III E probe to COM-V)

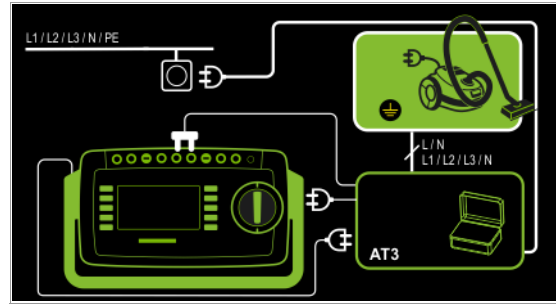

## Alternative Measuring Method (equivalent leakage current)

– *Alternative measurement type*

– DUT mains plug (protection class I) to test socket

## Schematic Diagram

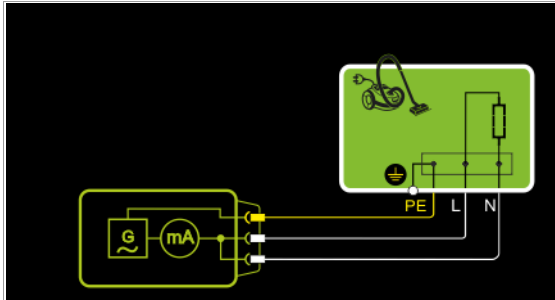

After activating test voltage, leakage current is measured via the DUT's mains cable between short-circuited mains conductors L and N and the protective conductor terminal at the DUT.

## Wiring Diagram

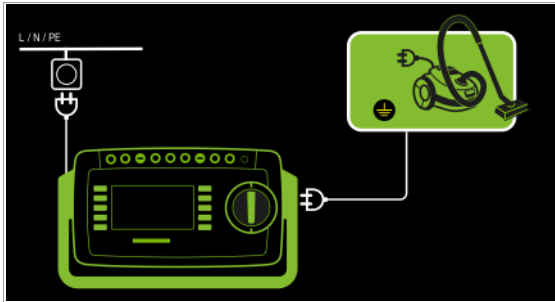

## Connection of 3-Phase DUTs (only with feature I01 with optional test adapter AT3-III E)

– *AT3-Adapter Measurement type*

– DUT mains plug to AT3-III E test adapter

– AT3-III E probe to COM-V terminals

– AT3-III E test plug to test socket

## Schematic Diagram

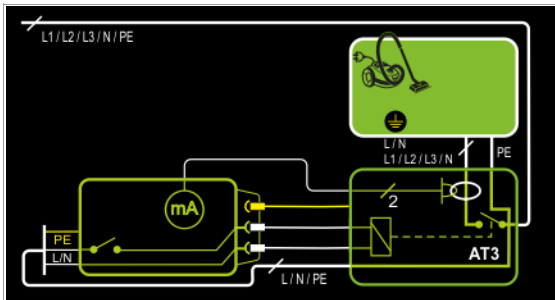

Measurement of the DUT with 3-phase mains connection via AT3-III E adapter

## Measurement of Protective Conductor Current via Current Clamp Sensor with Voltage Output for Permanently Installed DUTs (only with feature I01 with optional current clamp sensor)

– *Clamp measurement type*

## Schematic Diagram

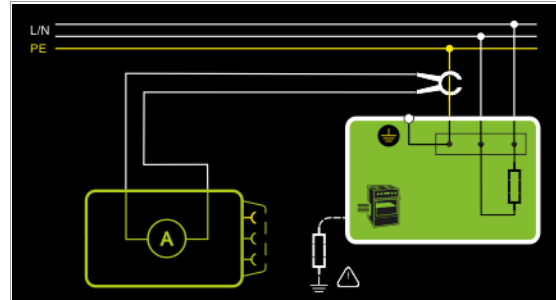

Measurement of protective conductor current by closing the current clamp sensor around mains cable PE for permanently installed protection class I devices under test

## Wiring Diagram (current clamp sensor to COM-V)

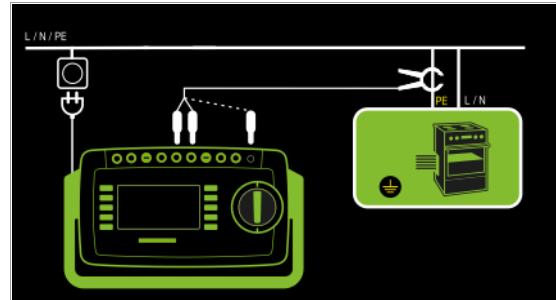

## Setting Measuring Range at the Clamp and Parameters at the Test Instrument

Test Instrument Parameter: Transformation Ratio	Clamp		Test Instrument Display Range with Clamp
	Transformation Ratio (switch *)	Measuring Range	
1 mV : 1 mA	WZ12C		0 mA ... 300 A
	1 mV : 1 mA	1 mA ... 15 A	
100 mV : 1 mA	SECUTEST CLIP		0.00 mA ... 3.00 A
	100 mV : 1 mA	0.1 ... 25 mA	

\* Only with WZ12C

\*\* Default value

## Setting Measuring Parameters for IPE



Measuring Parameter	Meaning	
<b>Measurement Type</b>		Suitable for DUT Connection via
<b>Direct</b>	Direct earth leakage current measurement between PE(mains) and PE(TS)	Test socket, AT16DI/AT32DI (direct or diff.)
<b>Differential</b>	Earth leakage current measurement in accordance with the differential current measuring method L/N(TS), PE(TS) is grounded	Test socket
<b>Alternative</b>	Equivalent leakage current measurement with equivalent source between PE and L/N at the test socket (L/N short-circuited)	Test socket, VL2E, AT3 adapter (AT3-IIIE, AT3-IIS, AT3-IIS32), AT16DI/AT32DI
<b>AT3 adapter</b>	Earth leakage current measurement via residual current converter in the AT3 adapter, measured via the V-COM sockets.	AT3-IIIE, AT3-IIS, AT3-IIS32
<b>Clamp</b>	Current clamp measurement as earth leakage current measurement for permanently connected devices (current clamp sensor with voltage output via the V-COM sockets with conversion to and display as current values)	Permanent connection
<b>TC – test conditions</b>		
None APP > PE: Connect APP to PE – all APP sockets are connected to PE potential when this option is activated.		
<b>Single fault (SFC) – only with direct measurement type</b>		
Normal state / N interrupted		
<b>Polarity</b>		With direct and differential measurement type only
<b>L/N or N/L</b>	Selection of polarity for mains voltage to the test socket	
<b>Clamp factor – only for clamp measurement type</b>		
<b>1 mV : 1 mA</b>	Transformation ratio of the <b>WZ12C</b> current clamp sensor. For setting the current clamp factor at the <b>WZ12C</b> clamp and the test instrument (see table above).	
<b>10 mV : 1 mA</b>		
<b>100 mV : 1 mA</b>	Transformation ratio of the <b>SECUTEST CLIP</b> current clamp sensor. For setting the current clamp factor at the test instrument.	
<b>1 V : 1 A</b>		



### Note

The currently selected **single fault** and the **test condition** are displayed on the initial page. In order to change them, they have to be selected and set via the measuring parameters menu. Single fault exception: This can be set via the **SFC** direct selection key.

The measurements have to be conducted under all fault conditions. Selection is made in the measuring parameters menu under **Single Fault**.

## Test Sequence for Direct Measuring Method

- ⇨ Before conducting any leakage current measurements, make sure that the “Ref. voltage L-PE” and “Alt. Test Freq.” measurement parameters have been correctly set in SETUP (see section 6.2).
- ⇨ Set the rotary switch to the **I<sub>PE</sub>** position.
- ⇨ Select the **Direct** measurement type:
  - By setting the parameters
  - or
  - Directly via the **Measurement Type** key
- ⇨ In the case of the **Direct** measuring type, the **Single Fault (SFC)** key and **Test Condition** parameters also have to be set.
- ⇨ Connect the DUT’s mains plug (protection class I) to the test instrument’s test socket.
- ⇨ Connect the applied parts.
- ⇨ Make sure that the device under test is switched off.
- ⇨ **Start the test:** press the **START/STOP** key.
- ⇨ Switch the device under test on.
- ⇨ The measurement must be performed with mains plug polarity in both directions by pressing the **NL/LN** key.
- ⇨ Acknowledge the warning which indicates that line voltage will be connected to the test socket.
- ⇨ Switch the device under test on.
- ⇨ Contact all accessible conductive parts, one after the other, with test probe P1, which are not connected to the housing, as well as any output sockets for safety extra-low voltage if included.
- ⇨ The measured values are displayed. The measured value recording symbol shown at the right appears. Each time this key is pressed, the currently displayed measured value is saved to buffer memory.
- ⇨ Turn off the device under test.
- ⇨ **End the test:** press the **START/STOP** key. The save symbol appears (floppy disk showing the number of measured values stored to buffer memory) and prompts you to save the measured values to an ID number.
- ⇨ Read the measured values and compare them with the table of permissible limit values.
- ⇨ Press the **ESC** key in order to discard the measured values stored to buffer memory and acknowledge by pressing the key shown at the right.

## Test Sequence with AT3-IIIE Adapter











### Attention!

Please observe the operating instructions for the AT3-IIIE regarding correct connection of the test adapter and the device under test, as well as peculiarities involved in the test sequence.



## Test Sequence with Differential Current Method

- ⇨ Before conducting any leakage current measurements, make sure that the “Ref. voltage L-PE” and “Alt. Test Freq.” measurement parameters have been correctly set in SETUP (see section 6.2).
- ⇨ Set the rotary switch to the  $I_{PE}$  position.
- ⇨ Select the **Differential** measurement type:
  - By setting the parameters
  - or
  - Directly via the **Measurement Type** key 
- ⇨ Connect the test object’s mains plug (protection class I) to the test instrument’s test socket.
- ⇨ **Start the test:** press the **START/STOP** key. 
- ⇨ The measurement must be performed with mains plug polarity in both directions by pressing the **NL/LN** key. 
- ⇨ Acknowledge the warning which indicates that line voltage will be connected to the test socket. 
- ⇨ Switch the device under test on.
- ⇨ The measured values are displayed. The measured value recording symbol shown at the right appears. Each time this key is pressed, the currently displayed measured value is saved to buffer memory. 
- ⇨ Turn off the device under test.
- ⇨ **End the test:** press the **START/STOP** key. The save symbol appears (floppy disk showing the number of measured values stored to buffer memory) and prompts you to save the measured values to an ID number.   

- ⇨ Read the measured values and compare them with the table of permissible limit values.
- ⇨ Press the **ESC** key in order to discard the measured values stored to buffer memory and acknowledge by pressing the key shown at the right. 

## Maximum Permissible Limit Values for Leakage Current in mA

Test Standard	$I_{PE}$
VDE 0701-0702:2008	PC I: 3.5 1 mA/kW *
DIN EN 60974-4 VDE 0544-4:2009-06	5 mA

\* For devices with heating power of greater than 3.5 kW

Note 1: Devices which are not equipped with accessible parts that are connected to the protective conductor, and which comply with requirements for touch current and, if applicable, patient leakage current, e.g. computer equipment with shielded power pack

Note 2: Permanently connected devices with protective conductor







Note 3: Portable X-ray devices with mineral insulation

### Key

$I_{PE}$  Current in the protective conductor (primary leakage current)

See section 14.8 for further limit values.

## Test Sequence for Alternative Measuring Method

- ⇨ Before conducting any leakage current measurements, make sure that the “Ref. voltage L-PE” and “Alt. Test Freq.” measurement parameters have been correctly set in SETUP (see section 6.2).
- ⇨ Set the rotary switch to the  $I_{PE}$  position.
- ⇨ Select the **Alternative** measurement type:
  - By setting the parameters
  - or
  - Directly via the **Measurement Type** key 
- ⇨ Connect the DUT’s mains plug (protection class I) to the test instrument’s test socket.
- ⇨ **Start the test:** press the **START/STOP** key. 
- ⇨ Switch the device under test on.
- ⇨ The measured values are displayed. The measured value recording symbol shown at the right appears. Each time this key is pressed, the currently displayed measured value is saved to buffer memory. 
- ⇨ **End the test:** press the **START/STOP** key. The save symbol appears (floppy disk showing the number of measured values stored to buffer memory) and prompts you to save the measured values to an ID number.   

- ⇨ Read the measured values and compare them with the table of permissible limit values.
- ⇨ Press the **ESC** key in order to discard the measured values stored to buffer memory and acknowledge by pressing the key shown at the right. 

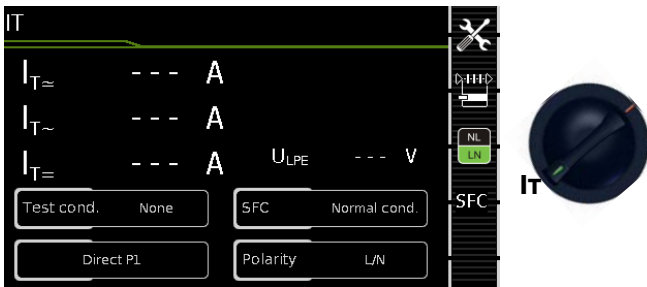

## 8.7.2 Touch Current – IT



### Single measurements, rotary switch level: green

Switch Position	Measurement Type With Mains to Test Socket	Measurement Type Without Mains to Test Socket	Measuring Functions
I <sub>T</sub>	Direct P1		I <sub>T</sub> ≈ Touch current, TRMS I <sub>T</sub> ~ AC component I <sub>T</sub> = DC component U <sub>LN</sub> Test voltage
	Differential P1		I <sub>T</sub> ≈ Touch current, TRMS U <sub>LN</sub> Test voltage
		Alternative P1	I <sub>T</sub> ≈ Touch current, TRMS U <sub>LN</sub> Test voltage
		Perm. conn. P1	I <sub>T</sub> ≈ Touch current, TRMS I <sub>T</sub> ~ AC component I <sub>T</sub> = DC component
		Alternative P1–P2	I <sub>T</sub> ≈ Touch current, TRMS U <sub>LN</sub> Test voltage

### Applications

Make sure that the contacted parts are not grounded.

### Definition

Current which flows from housing parts which are not connected to the protective conductor via an external conductive connection to earth or another part of the housing. Flow of current via the protective conductor is excluded in this case.

The following designations are also common: housing leakage current, probe current.

### Direct Measuring Method

- Measurement type direct P1
- DUT mains plug to test socket
- Test probe P1 to P1 terminals

### Schematic Diagram

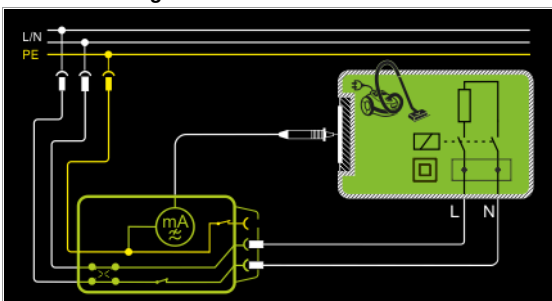

The device under test is operated with mains power. Current which flows to the protective conductor via exposed conductive parts and via the probe is measured. The measurements must be performed with mains plug polarity in both directions. Polarity is reversed with the **NL/LN** key. The TRMS, the AC or the DC component of the current is measured.

### Wiring Diagram

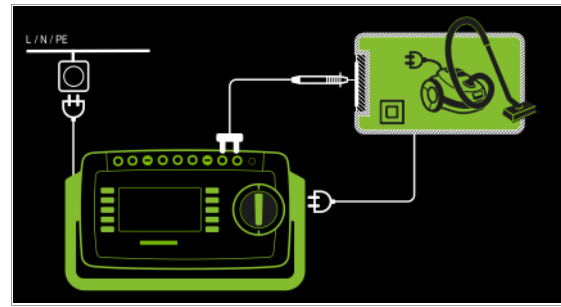

### Note

Regarding protection class I DUTs:

Parts may or may not be grounded.

Coincidental grounding only occurs in the event of an error.

### Direct Measuring Method

- Measurement type direct P1
- DUT mains plug to test socket
- Test probe P1 to P1 terminals
- APPs to APP sockets

### Schematic Diagram

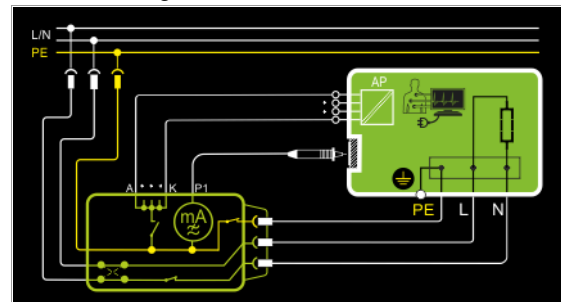

The device under test is operated with mains power. Current which flows to the protective conductor via exposed conductive parts, the probe and the connected applied parts is measured. The measurements must be performed with mains plug polarity in both directions. Polarity is reversed with the **NL/LN** key. The TRMS, the AC or the DC component of the current is measured.

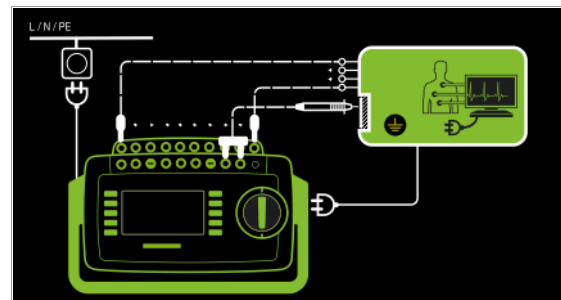

### Differential Current Method

- Measurement type differential P1
- DUT mains plug to test socket
- Test probe P1 to P1 terminals

#### Schematic Diagram

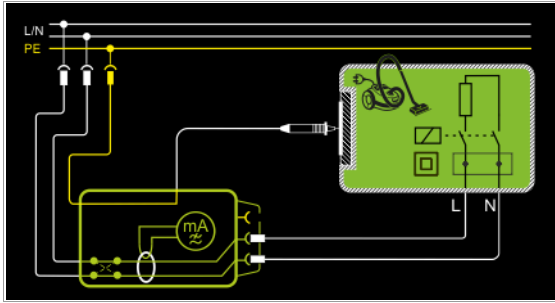

The device under test (PC2) is operated with mains power. Differential current which flows via the two mains conductors is measured (current clamp measurement concept). The measurements must be performed with mains plug polarity in both directions. Polarity is reversed with the **NL/LN** key. The current's AC component is measured. Accessible conductive parts must be contacted with test probe P1.

#### Wiring Diagram

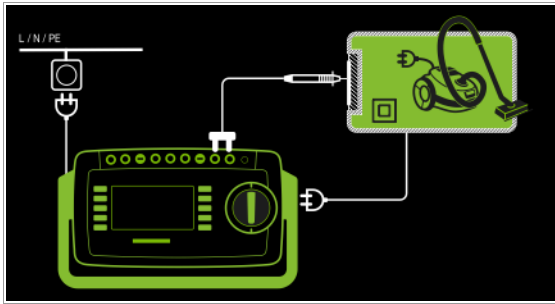

### Alternative Measuring Method (equivalent leakage current)

- Measurement type alternative P1
- DUT mains plug to test socket
- Test probe P1 to P1 terminals

#### Schematic Diagram

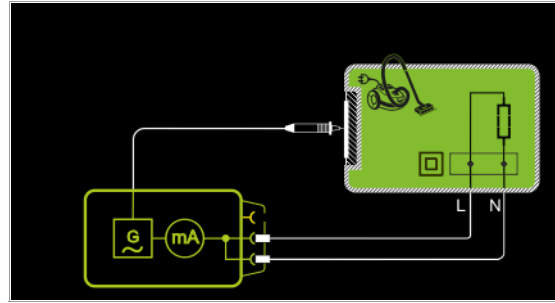

After activating test voltage, leakage current is measured between short-circuited mains conductors L and N (DUT mains plug) and accessible conductive parts (probe contact). The TRMS, the AC or the DC component of the current is measured.

#### Wiring Diagram

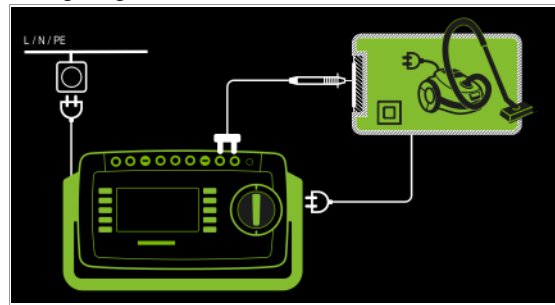

### Direct Measuring Method for Permanently Installed DUTs

- Measurement type: permanent connection P1
- Test probe P1 to P1 terminals

#### Schematic Diagram

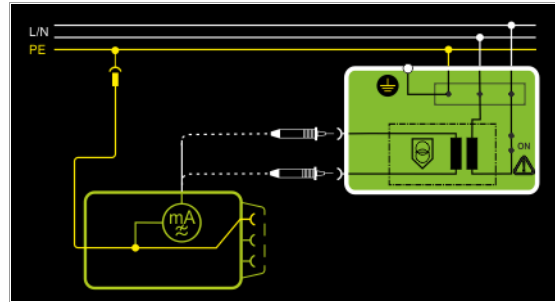

The DUT is operated with line voltage from a permanent installation. Leakage current is measured between the protective conductor at the mains and the output sockets for safety extra-low voltage at the DUT, one after the other, with the help of the test probe. Furthermore, accessible, conductive parts which are **not** connected to the housing must also be contacted.

#### Wiring Diagram

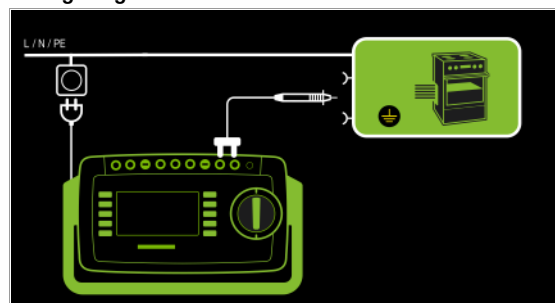

## Alternative measuring method with 2-pole measurement (P1–P2)

– *Alternative measurement type (P1 - P2)*

– Test probe P1 to P1 terminals

– Test probe P2 to P2 terminals

### Schematic Diagram

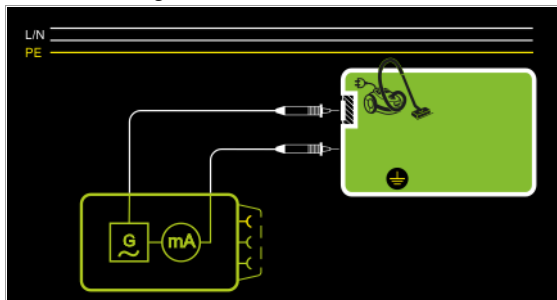

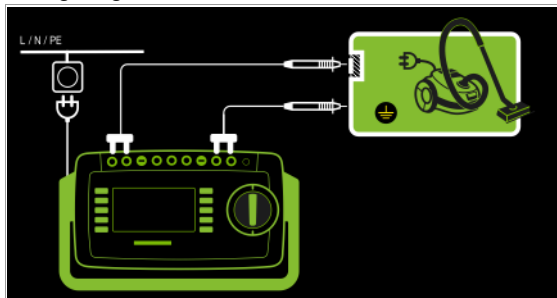

Touch current is measured between external conductive parts which can be contacted with test probe P2 and are **not** connected to the housing, and the housing with test probe P1.

### Wiring Diagram



## Setting Measuring Parameters for IT



Measuring Parameter	Meaning	
<b>Measurement Type</b>		 Suitable for DUT Connection via
<b>Direct P1</b>	Direct measurement of touch current between PE (mains) and probe P1	Test socket, AT3 adapter (AT3-III E, AT3-IIS, AT3-IIS32), AT16DI/AT32DI
<b>Differential P1</b>	Measurement of touch current in accordance with the differential current measuring method L/N (TS), exposed parts are grounded via probe P1 (via 1 kΩ)	Test socket
<b>Alternative P1</b>	Measurement of touch current with equivalent source between probe P1 and L/N at the test socket (short-circuited)	Test socket, AT3 adapter (AT3-III E, AT3-IIS, AT3-IIS32), AT16DI/AT32DI, VL2E
<b>Perm. conn. P1</b>	Direct measurement of touch current between PE (mains) and probe P1	Permanent connection
<b>Alternative P1–P2</b>	Measurement of touch current with equivalent source between probe P1 and probe P2	No connection, PC3: 2-pole measurement between test probes 1 and 2 (see section 6.6)
<b>TC – test conditions – only for measurement types direct P1 and permanent connection P1</b>		
None		
APP > PE: Connect APP to PE – all APP sockets are connected to PE potential when this option is activated.		
<b>Single fault (SFC) – only with measurement type direct P1</b>		
Normal state / N interrupted / PE interrupted		
<b>Polarity</b>		With direct and differential measurement type only
<b>L/N or N/L</b>	Selection of polarity for mains voltage to the test socket	



### Note

The currently selected **single fault** and the **test condition** are displayed on the initial page. In order to change them, they have to be selected and set via the measuring parameters menu . Single fault exception: This can be set via the **SFC** direct selection key.

The measurements have to be conducted under all fault conditions. Selection is made in the measuring parameters menu under **Single Fault**.

### Direct Selection – Setting Polarity – for Direct and Differential Only





Measuring Parameter	Meaning
<b>Measurement Type</b>	
<b>L/N or N/L</b>	Selection of polarity for mains voltage to the test socket

### Prerequisites for Touch Current Measurement

- Visual inspection has been passed.
- For protection class I devices Protective conductor resistance testing has been passed.
- Insulation resistance testing has been passed.







## Test Sequence for Direct and Differential Current Methods

- ⇨ Before conducting any leakage current measurements, make sure that the “Ref. voltage L-PE” and “Alt. Test Freq.” measurement parameters have been correctly set in SETUP (see section 6.2).
- ⇨ Set the rotary switch to the  $I_T$  position.
- ⇨ Select measurement type **Direct P1** or **Differential P1**:
  - By setting the parameters
  - or
  - Directly via the **Measurement Type** key 
- ⇨ In the case of measurement type **Direct P1**, the **Single Fault** parameter (**SFC** key) must be additionally set.
- ⇨ In the case of measurement type **Direct P1** or **Permanent Connection P1**, the **Test Condition** parameter must be additionally set.
- ⇨ In the case of **direct and differential current measurement**, measurement must be performed with mains plug polarity in both directions. Select the respective polarity to this end by pressing the **NL/LN** key. 
- ⇨ Connect the DUT's mains plug (protection class II) to the test instrument's test socket.









### Attention!

Testing is conducted in the presence of line voltage.

- ⇨ In the case of measurement type **Direct** and test condition **APP > PE**: Connect the applied parts.
- ⇨ **Start the test**: press the **START/STOP** key. 
- ⇨ Acknowledge the warning which indicates that line voltage will be connected to the test socket. 
- ⇨ Switch the device under test on.
- ⇨ Contact all accessible conductive parts, one after the other, which are not connected to the housing with test probe P1.
- ⇨ The measured values are displayed. The measured value recording symbol shown at the right appears. Each time this key is pressed, the currently displayed measured value is saved to buffer memory. 
- ⇨ Turn off the device under test.
- ⇨ **End the test**: press the **START/STOP** key. The save symbol appears (floppy disk showing the number of measured values stored to buffer memory) and prompts you to save the measured values to an ID number.   

- ⇨ Read the measured values and compare them with the table of permissible limit values.
- ⇨ Press the **ESC** key in order to discard the measured values stored to buffer memory and acknowledge by pressing the key shown at the right. 

## Test Sequence for Alternative Measuring Method

- ⇨ Before conducting any leakage current measurements, make sure that the “Ref. voltage L-PE” and “Alt. Test Freq.” measurement parameters have been correctly set in SETUP (see section 6.2).
- ⇨ Set the rotary switch to the  $I_T$  position.
- ⇨ Select measurement type **Alternative P1** or **Alternative P1–P2** (feature H01):
  - By setting the parameters
  - or
  - Directly via the **Measurement Type** key 
- ⇨ Connect the DUT's mains plug (protection class II) to the test instrument's test socket.
- ⇨ **Start the test**: press the **START/STOP** key. 
- ⇨ Contact all accessible conductive parts, one after the other, which are not connected to the housing with test probe P1.
- ⇨ The measured values are displayed. The measured value recording symbol shown at the right appears. Each time this key is pressed, the currently displayed measured value is saved to buffer memory. 
- ⇨ **End the test**: press the **START/STOP** key. The save symbol appears (floppy disk showing the number of measured values stored to buffer memory) and prompts you to save the measured values to an ID number.   

- ⇨ Read the measured values and compare them with the table of permissible limit values.
- ⇨ Press the **ESC** key in order to discard the measured values stored to buffer memory and acknowledge by pressing the key shown at the right. 

### Maximum Permissible Limit Values for Leakage Current in mA

Test Standard	$I_C$
VDE 0701-0702:2008	0.5
DIN EN 60974-4 VDE 0544-4:2009-06	10 mA

#### Key

$I_T$  Touch current (leakage current from welding current)

See section 14.8 for further limit values.

### 8.7.3 Device Leakage Current – IE

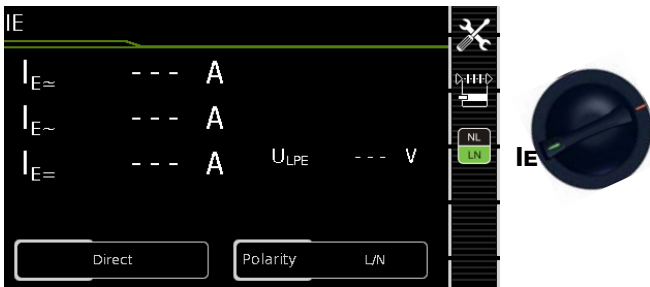

Single measurements, rotary switch level: green			
Switch Position	Measurement Type With Mains to Test Socket	Measurement Type Without Mains to Test Socket	Measuring Functions
I <sub>E</sub>	Direct		I <sub>E~</sub> Device leakage current, TRMS I <sub>E~</sub> AC component I <sub>E=</sub> DC component U <sub>LN</sub> Test voltage
	Differential		I <sub>E~</sub> Device leakage current, TRMS U <sub>LN</sub> Test voltage
		Alternative	I <sub>E~</sub> Device leakage current, TRMS U <sub>LN</sub> Test voltage
	AT3 adapter <sup>1</sup>		I <sub>E~</sub> Device leakage current, TRMS U <sub>LN</sub> Test voltage
		Clamp <sup>2</sup>	I <sub>E~</sub> Device leakage current, TRMS U <sub>LN</sub> Test voltage

<sup>1</sup> Adapter AT3-IIIIE, AT3-IIS or AT3-II S32:  
Voltage measuring inputs for leakage current measurement with differential method (instrument with feature I01)

<sup>2</sup> Voltage measuring inputs for leakage current measurement with differential method and use of a current clamp sensor with (instrument with feature I01)

#### Applications

Measurement of device leakage current is required for medical electrical equipment in accordance with IEC 62353 (VDE 0751-1).

In the case of device leakage current as the sum of all leakage current, all probe contact points must be contacted simultaneously.

#### Definition

Device leakage current is the sum of all leakage current from the housing, accessible conductive parts and applied parts to PE.

#### Direct Measuring Method

- Direct measurement type
- DUT mains plug to test socket
- APPs to APP sockets
- Test probe P1 to P1 terminals

#### Schematic Diagram

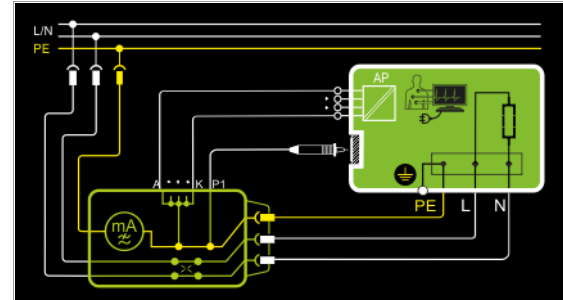

The device under test (PC1) is operated with mains power. Protective conductor current is measured between the protective conductor at the mains (test instrument supply power) and the protective conductor terminal at the DUT via the DUT's mains cable. The measurements must be performed with mains plug polarity in both directions. Polarity is reversed with the **NL/LN** key. Accessible conductive parts which are not connected to the housing must be contacted with test probe P1.

If the DUT includes terminals for applied parts, they must be connected to the test instrument's APP sockets. These are short-circuited in the test instrument and connected to the protective conductor terminal at the DUT.

#### Wiring Diagram

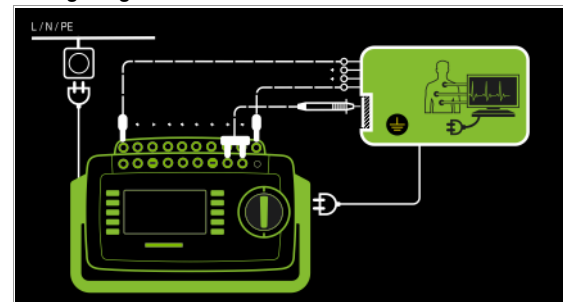

## Differential Current Measurement

- *Differential measurement type*
- DUT mains plug to test socket
- APPs to APP sockets
- Test probe P1 to P1 terminals

### Schematic Diagram

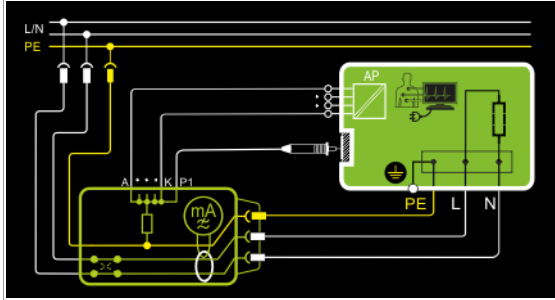

The device under test (PC1) is operated with mains power. Differential current which flows via the two mains conductors is measured (current clamp measurement concept). The measurements must be performed with mains plug polarity in both directions. Polarity is reversed with the **NL/LN** key. Accessible conductive parts which are not connected to the housing must be contacted with test probe P1. If the DUT includes terminals for applied parts, they must be connected to the test instrument's APP sockets. These are short-circuited in the test instrument and connected to the terminal for test probe P1.

### Wiring Diagram

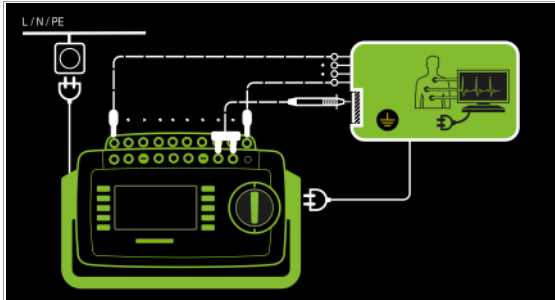

## Alternative Measuring Method (equivalent leakage current)

- *Alternative Measurement Type (P1)*
- DUT mains plug connected to the test socket
- APPs to APP sockets
- Test probe P1 to P1 terminals

### Schematic Diagram

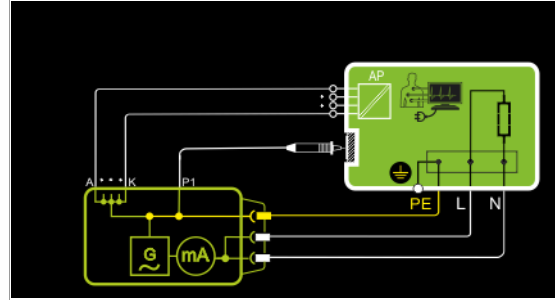

After activating test voltage, leakage current is measured between short-circuited mains conductors L and N (DUT mains plug) and accessible conductive parts (probe contact, test probe P1) which **are not connected to the housing**.

If the DUT includes terminals for applied parts, they must be connected to the test instrument's APP sockets. These are short-circuited in the test instrument and connected to the terminal for test probe P1 and the protective conductor terminal at the DUT.

### Wiring Diagram

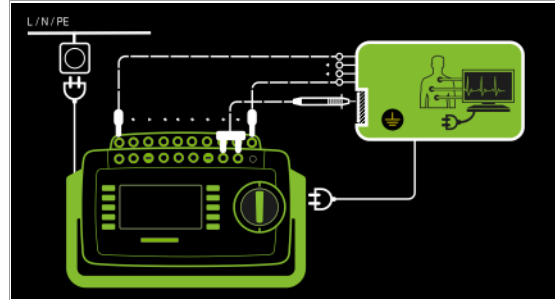

### Differential Current Measurement

- AT3-Adapter measurement type
- DUT mains plug to AT3-IIIE test adapter
- All APPs to all APP sockets
- Test probe P1 to P1 terminals
- AT3-IIIE probe to COM-V terminals
- AT3-IIIE test plug to test socket
- APPs to APP sockets

### Schematic Diagram

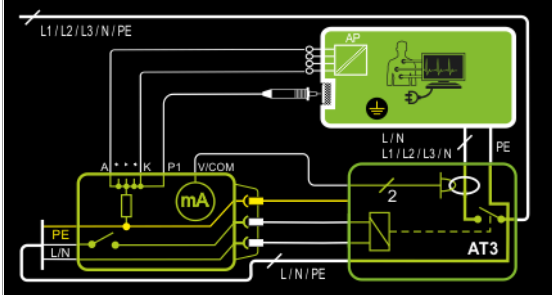

Measurement at the DUT with 3-phase mains connection via AT3-IIIE adapter

If the DUT includes terminals for applied parts, they must be connected to the test instrument's APP sockets. These are short-circuited in the test instrument and connected to the terminal for test probe P1.

Accessible conductive parts which are not connected to the housing must be contacted with test probe P1.

### Wiring Diagram

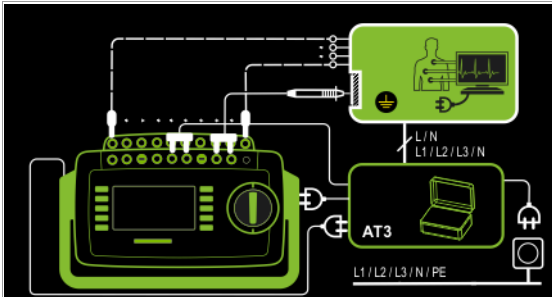

### Measurement Method with Current Clamp Sensor for Permanently Installed DUTs

- Clamp measurement type
- APPs to APP sockets
- Clamp to COM-V (feature IO1 with optional current clamp sensor)

### Schematic Diagram

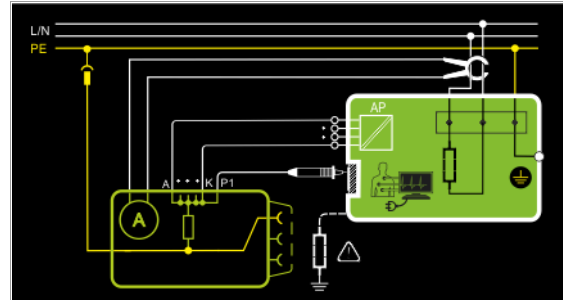

Measurement of device leakage current by closing the current clamp sensor around the L and N conductors of the mains cable for permanently installed protection class I devices under test

If the DUT includes terminals for applied parts, they must be connected to the test instrument's APP sockets. These are short-circuited in the test instrument and connected to the terminal for test probe P1.

Accessible conductive parts which are not connected to the housing must be contacted with test probe P1.

### Wiring Diagram

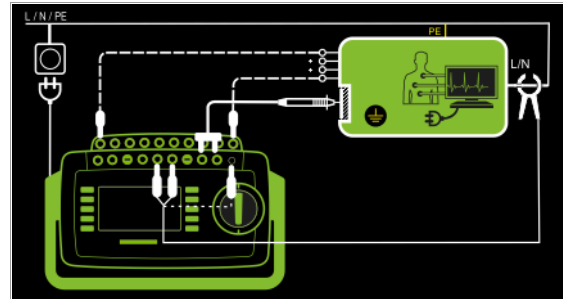



## Setting Measuring Range at the Clamp and Parameters at the Test Instrument

Test Instrument	Clamp		Test Instrument
Parameter: Transformation Ratio	Transformation Ratio (switch *)	Measuring Range	Display Range with Clamp
1 mV : 1 mA	WZ12C		0 mA ... 300 A
	1 mV : 1 mA	1 mA ... 15 A	
100 mV : 1 mA	SECUTEST CLIP		0.00 mA ... 3.00 A
	100 mV : 1 mA	0.1 ... 25 mA	

\* Only with WZ12C

\*\* Default value

## Setting Measuring Parameters for IE



Measuring Parameter	Meaning	
Measurement Type		Suitable for DUT Connection via
Direct	Direct measuring method (probe P1, PE(TS), all APP sockets)	Test socket, AT16DI/AT32DI (only diff. is sensible)
Differential	Measurement in accordance with differential current measuring method L/N (TS). Probe P1 and if applicable all APP sockets are grounded via 1 kΩ.	Test socket
Alternative	Equivalent leakage current measurement with equivalent source between PE and L/N at the test socket (L/N short-circuited) and if applicable all APP sockets	Test socket, AT16DI/AT32DI
AT3 adapter	Feature I01: Measurement via residual current converter in the AT3 adapter, measured via the V-COM sockets. Probe P1 and if applicable all APP sockets are grounded via 1 kΩ.	AT3-IIIE, AT3-IIS, AT3-IIS32
Clamp	Feature I01: Measurement of device leakage current via current clamp sensor with voltage output (V-COM sockets), with conversion to and display as current values. Probe P1 and if applicable all APP sockets are grounded via 1 kΩ.	Permanent connection
Polarity <sup>1</sup>		For direct, differential and AT3 adapter measurement types only
L/N or N/L	Selection of polarity for mains voltage to the test socket	
<b>Clamp factor – only for clamp measurement type</b>		
1 mV : 1 mA	Transformation ratio of the WZ12C current clamp sensor. For setting the current clamp factor at the WZ12C clamp and the test instrument (see table above).	
10 mV : 1 mA		
100 mV : 1 mA	Transformation ratio of the SECUTEST CLIP current clamp sensor. For setting the current clamp factor at the test instrument.	
1 V : 1 A		

<sup>1</sup> Measurement must be performed with mains polarity in both directions. The largest value is documented

## Test Sequence

- ⇨ Before conducting any leakage current measurements, make sure that the “Ref. voltage L-PE” and “Alt. Test Freq.” measurement parameters have been correctly set in SETUP (see section 6.2).
- ⇨ Set the rotary switch to the I<sub>E</sub> position.
- ⇨ Connect the DUT in accordance with the selected measuring method.
- ⇨ Connect the applied parts.
- ⇨ Select the measurement type:
  - By setting the parameters
  - or
  - Directly via the **Measurement Type** key
- ⇨ In the case of **direct and differential current measurement**, measurement must be performed with mains plug polarity in both directions. Select the respective polarity to this end by pressing the **NL/LN** key.
- ⇨ Start the test: press the **START/STOP** key.
- ⇨ After each reconnection to the mains, and as soon as the first test is started, a mains connection test is executed.
- ⇨ You're prompted to connect test probe P1. The probe fuse is tested.
- ⇨ **In the case of the direct or differential measurement type:** Acknowledge the warning which indicates that line voltage will be connected to the test socket.
- ⇨ Switch the device under test on.
- ⇨ The measured values are displayed. The measured value recording symbol shown at the right appears. Each time this key is pressed, the currently displayed measured value is saved to buffer memory.
- ⇨ Turn off the device under test.
- ⇨ **End the test:** press the **START/STOP** key. The save symbol appears (floppy disk showing the number of measured values stored to buffer memory) and prompts you to save the measured values to an ID number.
- ⇨ Read the measured values and compare them with the table of permissible limit values.
- ⇨ Press the **ESC** key in order to discard the measured values stored to buffer memory and acknowledge by pressing the key shown at the right.

## Test Sequence with AT3-IIIE Adapter



### Attention!

Please observe the operating instructions for the AT3-IIIE regarding correct connection of the test adapter and the device under test, as well as peculiarities involved in the test sequence.

## Maximum Permissible Limit Values for Equivalent Leakage Current in mA

Test Standard	$I_{GA}$	$I_{EDL}$	
VDE 0701-0702	PC I: 3.5 / 1 mA/kW <sup>1</sup> PC II: 0.5		
IEC 62353 (VDE 0751-1)		PC II	0.2 <sup>2</sup>
		PC I (PE or parts connected to PE)	1
		Permanently connected devices with PE	10
		Portable X-ray devices with additional PE	5
		Portable X-ray devices without additional PE	2
		Devices with mineral insulation	5

$I_{GA}$  Device leakage current

$I_{EA}$  Equivalent leakage current

PE Protective conductor

<sup>1</sup> For devices with heating power  $\geq 3.5$  kW

<sup>2</sup> This limit value isn't taken into consideration in the DIN EN 62353 (VDE 0751-1) standard.

See section 14.8 for further limit values.

## 8.7.4 Leakage Current from the Applied Part – I<sub>A</sub>

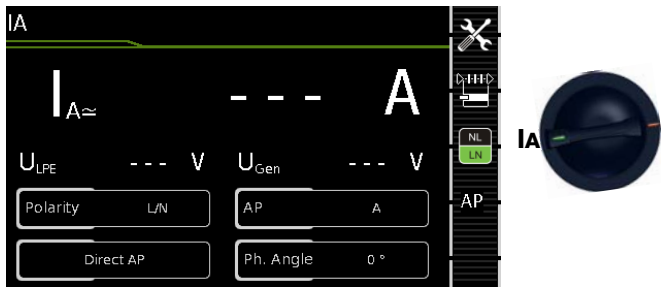

Single measurements, rotary switch level: green

Switch Position	Measurement Type With Mains to Test Socket	Measurement Type Without Mains to Test Socket	Measuring Functions
I <sub>A</sub>	Direct P1		I <sub>A</sub> ≈ U <sub>LPE</sub> U <sub>Gen</sub> Current from the applied part Test voltage Generator voltage
	Direct APP		
		Alternative P1	
		Alternative APP	
		Perm. conn. P1	
		Perm. conn. APP	
	APP – P2		

### Direct Measuring Method

- Measurement type: direct APP
- DUT mains plug (PC1) connected to test socket
- APPs to APP sockets

### Schematic Diagram

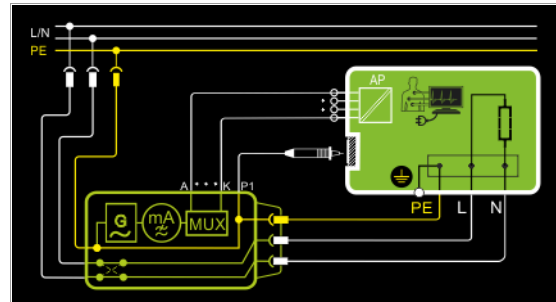

After activating **test voltage** and **line voltage**, leakage current from the application part is measured between the applied parts connected to the APP sockets at the test instrument and PE (DUT mains plug).

Power is supplied to the DUT via the test instrument. The device under test (PC1) is operated with mains power. The measurements must be performed with mains plug polarity in both directions. Polarity is reversed with the **NL/LN** key.

Accessible conductive parts which are not connected to the housing must be contacted with test probe P1.

### Wiring Diagram

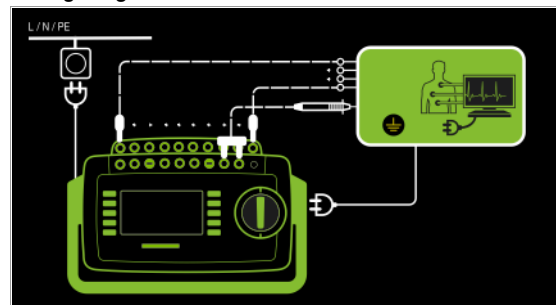

### Direct Measuring Method

- Measurement type direct P1
- DUT mains plug (PC1) connected to test socket
- Probe to P1 terminal

### Schematic Diagram

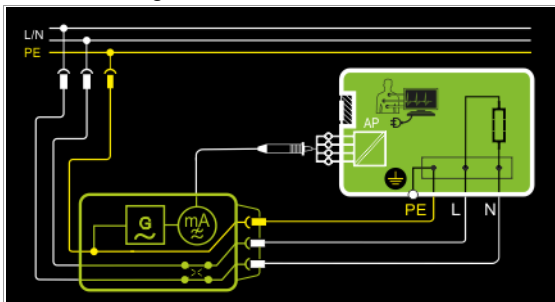

After activating **test voltage** and **line voltage**, leakage current from the application part is measured between the short-circuited terminals of the applied parts (test probe P1) and PE (DUT mains plug).

Power is supplied to the DUT via the test instrument. The device under test (PC1) is operated with mains power.

The measurements must be performed with mains plug polarity in both directions. Polarity is reversed with the **NL/LN** key.

### Wiring Diagram

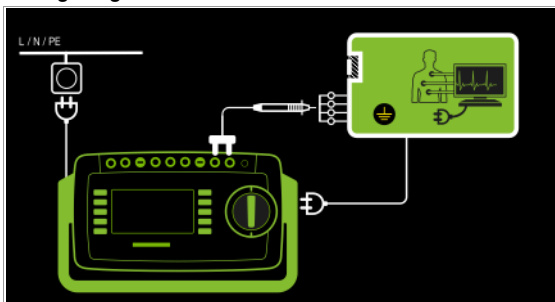

**Alternative Measuring Method (equivalent patient leakage current)**

- *Measurement type: alternative P1*
- DUT mains plug (PC1) connected to test socket
- Probe to P1 terminal

**Schematic Diagram**

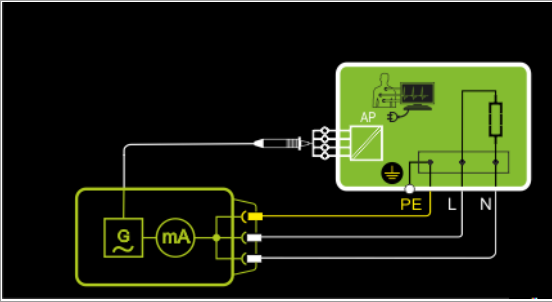

After activating test voltage, leakage current from the application part is measured between short-circuited conductors L-N-PE (DUT mains plug) and the short-circuited terminals of the applied parts (test probe P1).

**Wiring Diagram**

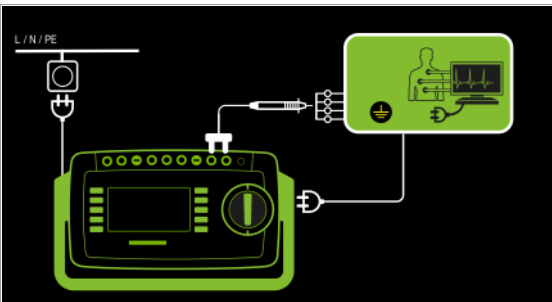

**Alternative Measuring Method (equivalent patient leakage current)**

- *Measurement type: alternative APP*
- DUT mains plug (PC1) connected to test socket
- APPs to APP sockets

**Schematic Diagram**

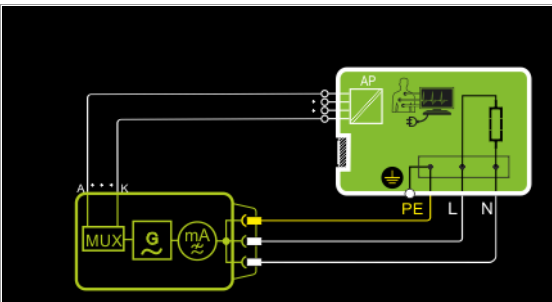

After activating test voltage, leakage current from the applied part is measured between short-circuited conductors L-N-PE (DUT mains plug) and the applied parts connected to the APP sockets at the test instrument.

**Wiring Diagram**

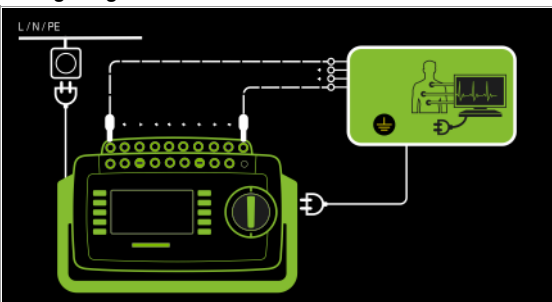

**Direct Measuring Method**

- *Measurement type: permanent connection P1*
- Permanent connection
- Probe to P1 terminal

**Schematic Diagram**

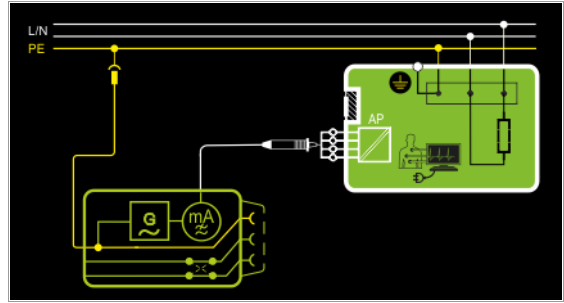

Leakage current from the applied part is measured between the short-circuited terminals of the applied parts (test probe P1) and PE at the mains connection.

**Wiring Diagram**

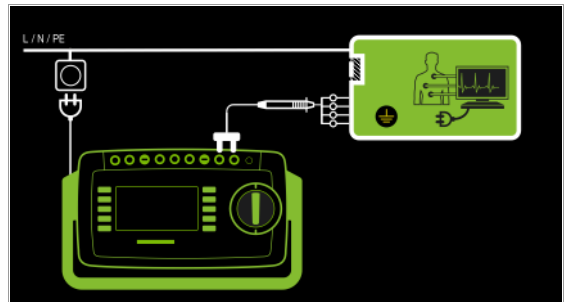

**Direct Measuring Method**

- *Measurement type: permanent connection APP*
- Permanent connection
- APPs to APP sockets

**Schematic Diagram**

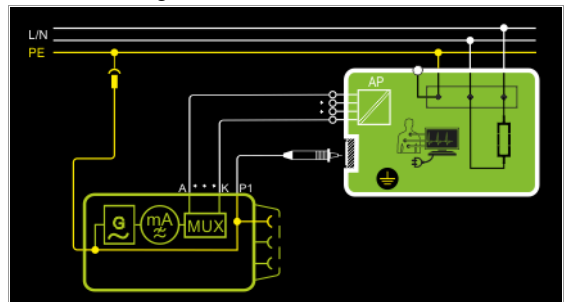

Leakage current from the applied part is measured between the applied parts connected to the APP sockets at the test instrument and PE at the mains connection.

Accessible conductive parts which are not connected to the housing must be contacted with test probe P1.

**Wiring Diagram**

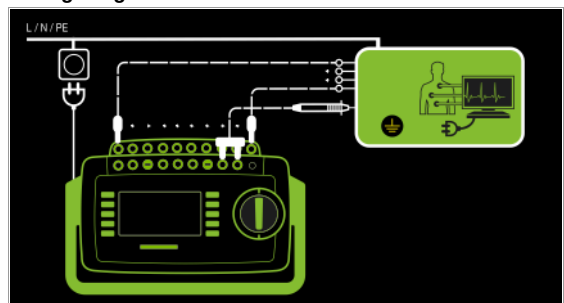

## Direct Measuring Method

- Measurement type APP - P2
- DUT mains plug (PC1) connected to test socket
- Probe to P2 terminal
- APPs to APP sockets

### Schematic Diagram

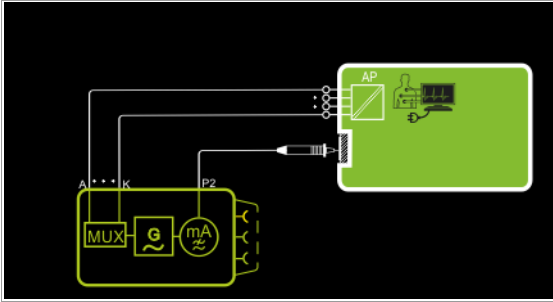

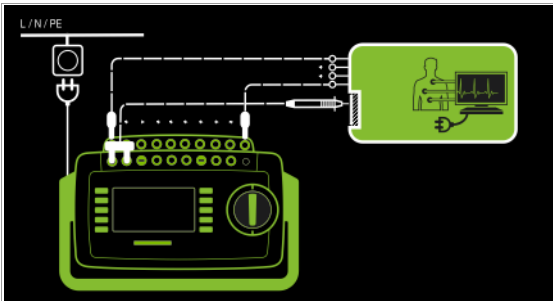

Leakage current from the applied part is measured between the applied parts connected to the APP sockets at the test instrument and exposed, conductive parts (test probe P2), which are not connected to the housing.

### Wiring Diagram



## Setting Measuring Parameters for IA











Measuring Parameter	Meaning	
<b>Measurement Type</b>		 Suitable for DUT Connection via
<b>Direct P1</b>	Direct measurement of leakage current from the applied part via probe P1	Test socket, AT3 adapter (AT3-IIE, AT3-IIS, AT3-IIS32), AT16DI/AT32DI
<b>Direct APP</b>	Direct measurement of leakage current from the applied part via selected APP socket(s)	Test socket
<b>Alternative P1</b>	Equivalent measurement of leakage current from the applied part via probe P1	Test socket
<b>Alternative APP</b>	Equivalent measurement of leakage current from the applied part via selected APP socket(s)	Test socket
<b>Perm. conn. P1</b>	Direct measurement of leakage current from the applied part via probe P1	Permanent connection
<b>Perm. conn. APP</b>	Direct measurement of leakage current from the applied part via selected APP socket(s)	Permanent connection
<b>APP – P2</b> <sup>1</sup>	Direct measurement of leakage current from the applied part between selected APP socket(s) and probe P2	APP-P2
<b>APP – applied parts</b>		
Individual selection: A / B / C / D / E / F / G / H / I / K, respectively via on/off		
<b>Phase angle – for direct and permanent connection measurement types only</b>		
<b>0° or 180°</b>	Selectable phasing for the internal generator relative to mains phasing	
<b>Polarity</b>		With direct only
<b>L/N or N/L</b>	Selection of polarity for mains voltage to the test socket	

<sup>1</sup> For ME equipment (medical electrical equipment) with own power supply

<sup>2</sup> This measurement only detects the portion of the leakage current which is generated due voltage coupling at the DUT's measuring input.

## Test Sequence

- ⇨ Before conducting any leakage current measurements, make sure that the “Ref. voltage L-PE” and “Alt. Test Freq.” measurement parameters have been correctly set in SETUP (see section 6.2).
- ⇨ Set the rotary switch to the  $I_A$  position.
- ⇨ Connect the DUT in accordance with the selected measuring method.
- ⇨ In the case of measurement type APP: Connect the applied parts.
- ⇨ Select the measurement type:
  - By setting the parameters
  - or
  - Directly via the **Measurement Type** key 
- ⇨ In the case of measurement type APP: Additionally select the respective applied parts by setting the utilized sockets to “on” and the unused sockets to “off”. 
- ⇨ In the case of **direct measurement**, measurement must be performed with mains plug polarity in both directions. Select the respective polarity to this end by pressing the **NL/LN** key. 
- ⇨ **Start the test:** press the **START/STOP** key. 
- ⇨ After each reconnection to the mains, and as soon as the first test is started, a mains connection test is executed.
- ⇨ **In the case of measurement type direct P1 or direct APP:** Acknowledge the warning which indicates that line voltage will be connected to the test socket. 
- ⇨ Switch the device under test on.
- ⇨ Contact the short-circuited applied parts with the test probe.
- ⇨ The measured values are displayed. The measured value recording symbol shown at the right appears. Each time this key is pressed, the currently displayed measured value is saved to buffer memory. 
- ⇨ Turn off the device under test.
- ⇨ **End the test:** press the **START/STOP** key. The save symbol appears (floppy disk showing the number of measured values stored to buffer memory) and prompts you to save the measured values to an ID number.   

- ⇨ Read the measured values and compare them with the table of permissible limit values.
- ⇨ Press the **ESC** key in order to discard the measured values stored to buffer memory and acknowledge by pressing the key shown at the right. 

See limit values in section 14.8.

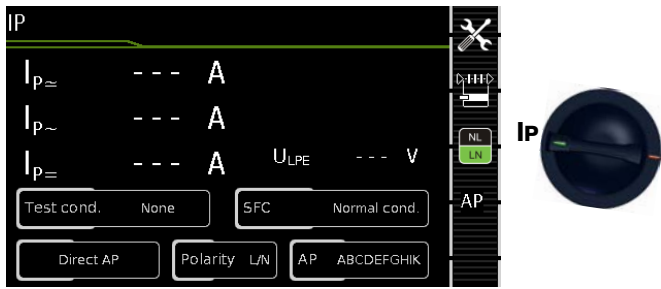
## 8.7.5 Patient Leakage Current – IP



Single measurements, rotary switch level: green

Switch Position	Measurement Type With Mains to Test Socket	Measurement Type Without Mains to Test Socket	Measuring Functions
Ip	Direct P1		$I_{P\sim}$ TRMS Patient leakage current,
	Direct APP		$I_{P\sim}$ AC component
		Perm. conn. P1	$I_{P=}$ DC component
		Perm. conn. APP	$U_{LPE}$ Test voltage

### Definition

Patient leakage current is the current which flows to ground or PE from the patient ports at the running device via the patient. The AC and the DC component of the current is measured.

### Direct Measuring Method

- Measurement type: direct P1
- DUT mains plug (PC1) connected to test socket
- Probe to P1 terminal

### Schematic Diagram

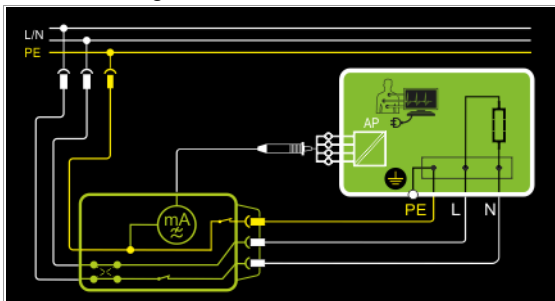

After activating test voltage, patient leakage current is measured at the DUT (test probe P1) between PE (DUT mains plug) and the short-circuited applied parts.

Power is supplied to the DUT via the test instrument. The device under test (PC1) is operated with mains power.

The measurements must be performed with mains plug polarity in both directions. Polarity is reversed with the **NL/LN** key.

Measurements are conducted with fixed fault condition **Normal State**.

### Wiring Diagram

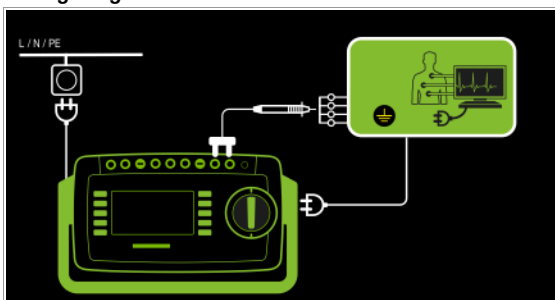

## – Special Case, Single Fault: Voltage at Applied Parts

### Schematic Diagram

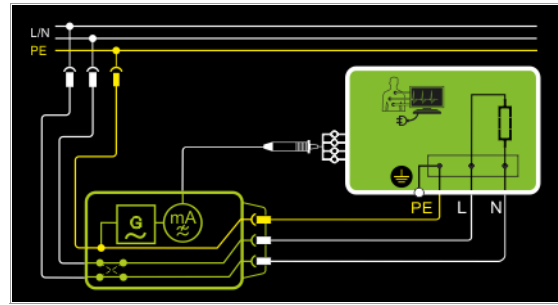

### Wiring Diagram

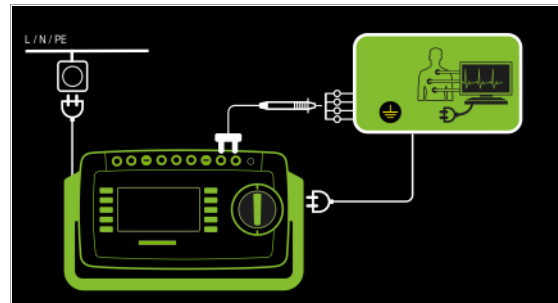

### Direct Measuring Method

- Measurement type: direct APP
- DUT mains plug (PC1) connected to test socket
- APPs to APP sockets
- Probe to P1 terminal

### Schematic Diagram

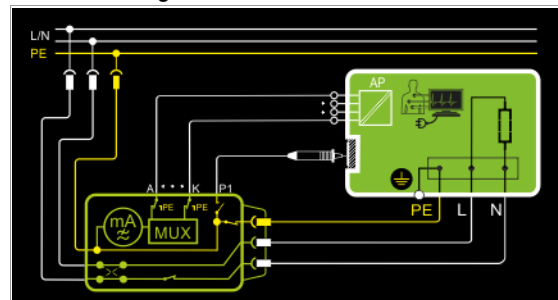

After activating test voltage, patient leakage current is measured between PE (DUT mains plug) and the applied parts connected to the APP sockets at the test instrument.

Power is supplied to the DUT via the test instrument. The device under test (PC1) is operated with mains power.

The measurements must be performed with mains plug polarity in both directions. Polarity is reversed with the **NL/LN** key.

Accessible conductive parts which are not connected to the housing must be contacted with test probe P1.

Measurements are conducted with fixed fault condition **Normal State** and test condition **None**.

### Wiring Diagram

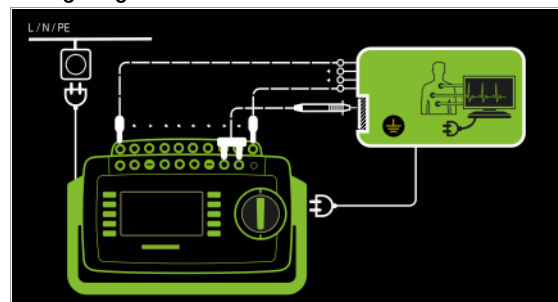



– Special Case, Single Fault: Voltage at Applied Parts

Schematic Diagram

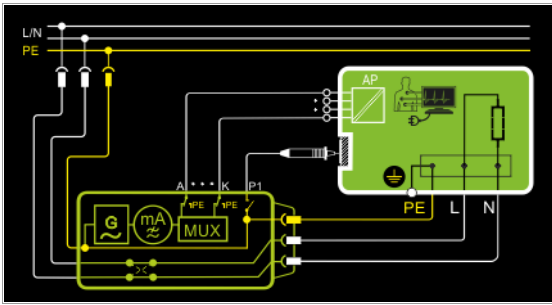

Voltage is activated between PE at the test socket/DUT and the applied parts.

Wiring Diagram

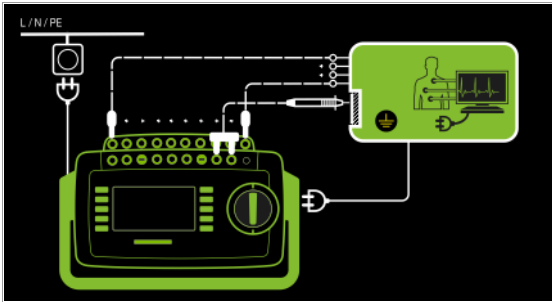

– Special Case, Single Fault: Voltage at Applied Parts

Schematic Diagram

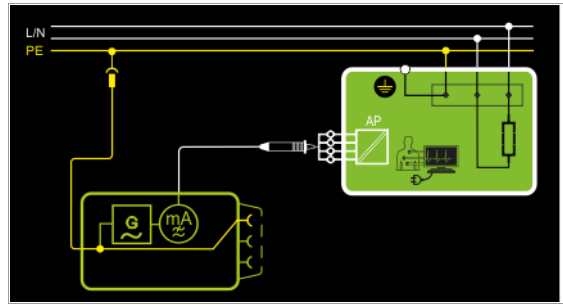

The fault condition **Voltage at Applied Part** between APP and PE is shown here.

Wiring Diagram

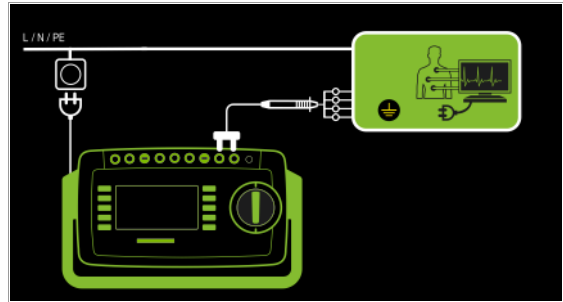

Direct Measuring Method

- Measurement type: permanent connection P1
- Permanent connection
- Probe to P1 terminal

Schematic Diagram

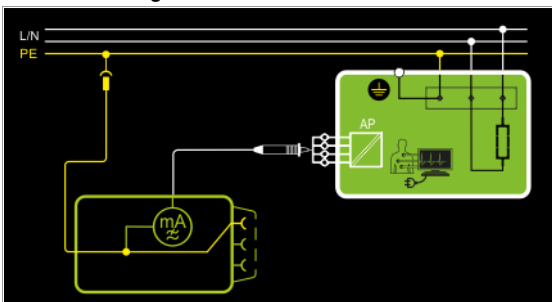

Patient leakage current is measured between the short-circuited patient terminals (test probe P1) and PE at the mains connection. Power is supplied to the DUT via the DUT's permanent connection. The device under test (PC1) is operated with mains power. The fault condition **Normal State** is shown here.

Wiring Diagram

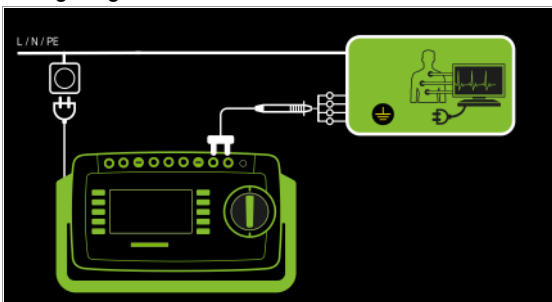

Direct Measuring Method

- Measurement type: permanent connection APP
- Permanent connection
- APPs to APP sockets

Schematic Diagram

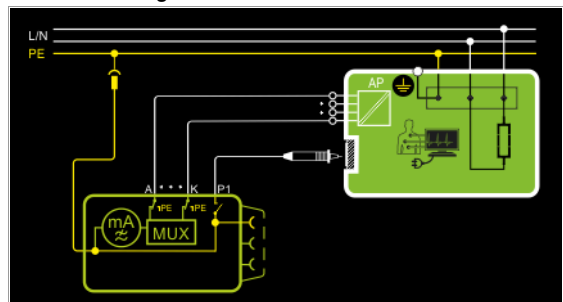

Patient leakage current is measured between the applied parts connected to the APP sockets at the test instrument and PE at the mains connection.

Power is supplied to the DUT via the DUT's permanent connection. The device under test (PC1) is operated with mains power. Accessible conductive parts which are not connected to the housing must be contacted with test probe P1. The fault condition **Normal State** is shown here.

Wiring Diagram

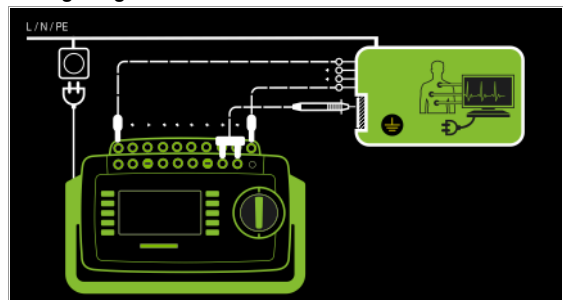

– Special Case, Single Fault: Voltage at Applied Parts

Schematic Diagram

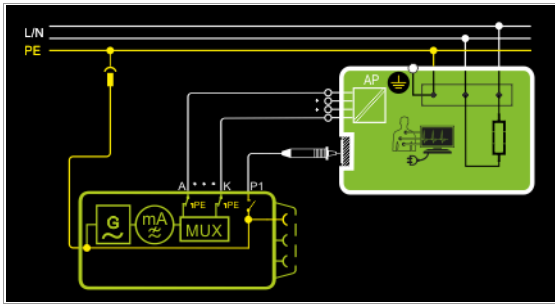

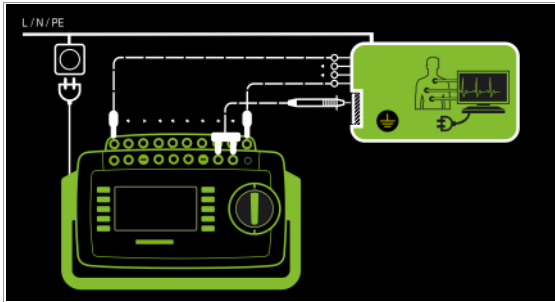

The fault condition **Voltage at Applied Parts** between APP and PE is shown here.

Wiring Diagram



Setting Measuring Parameters for IP



Measuring Parameter	Meaning	
<b>Measurement Type</b>		 <b>Suitable for DUT Connection via</b>
<b>Direct P1</b>	Direct measuring method (via test socket) with test probe P1	Test socket
<b>Direct APP</b>	Direct measuring method (via test socket) via selected APP socket(s).	Test socket
<b>Perm. conn. P1</b>	Measurement at permanently installed DUT with test probe P1	Permanent connection
<b>Perm. conn. APP</b>	Measurement at permanently installed DUT via selected APP socket(s).	Permanent connection
<b>Test conditions – for measurement type with APP only</b>		
None		
APP > PE: Connect applied part to PE – all APP sockets are connected to PE potential when this option is activated.		
Housing > PE: Connect housing to PE		
APP/Housing > PE: Connect housing and applied part to PE		
<b>APP – applied parts</b>		
Individual selection: A / B / C / D / E / F / G / H / I / K, respectively via on/off		
<b>Single fault (SFC)</b>		
Normal state / N interrupted / PE interrupted / voltage at APPs		
<b>Polarity</b>		Only with direct measurement type
<b>L/N or N/L</b>	Selection of polarity for mains voltage to the test socket	











**Note**

The currently selected **single fault** and the **test condition** are displayed on the initial page. In order to change them, they have to be selected and set via the measuring parameters menu .

The measurements have to be conducted under all fault conditions. Selection is made in the measuring parameters menu under **Single Fault**.

## Test Sequence

- ⇨ Before conducting any leakage current measurements, make sure that the “Ref. voltage L-PE” and “Alt. Test Freq.” measurement parameters have been correctly set in SETUP (see section 6.2).
- ⇨ Set the rotary switch to the  $I_p$  position.
- ⇨ Connect the DUT to the test socket.
- ⇨ In the case of measurement type APP: Connect the applied parts.
- ⇨ Select the measurement type:
  - By setting the parameters
  - or
  - Directly via the **Measurement Type** key 
- ⇨ Selected a single fault. 
- ⇨ In the case of measurement type APP: Additionally select the respective applied parts by setting the utilized sockets to “on” and the unused sockets to “off”.
- ⇨ In the case of **direct measurement P1**, measurement must be performed with mains plug polarity in both directions. Select the respective polarity to this end by pressing the **NL/LN** key. 
- ⇨ **Start the test:** press the **START/STOP** key. 
- ⇨ After each reconnection to the mains, and as soon as the first test is started, a mains connection test is executed.
- ⇨ **In the case of measurement type direct P1 or direct APP:** Acknowledge the warning which indicates that line voltage will be connected to the test socket. 
- ⇨ Switch the device under test on.
- ⇨ Contact the short-circuited inputs for the applied parts with test probe P1.
- ⇨ The measured values are displayed. The measured value recording symbol shown at the right appears. Each time this key is pressed, the currently displayed measured value is saved to buffer memory. 
- ⇨ Turn off the device under test.
- ⇨ **End the test:** press the **START/STOP** key. The save symbol appears (floppy disk showing the number of measured values stored to buffer memory) and prompts you to save the measured values to an ID number.   

- ⇨ Read the measured values and compare them with the table of permissible limit values.
- ⇨ Press the **ESC** key in order to discard the measured values stored to buffer memory and acknowledge by pressing the key shown at the right. 

## Maximum Permissible Limit Values for Leakage Current in mA

Test Standard		$I_p$		
		Type B	Type BF	Type CF
IEC 62353 (VDE 0751-1)	Direct current	0.01	0.01	0.01
	Alternating current	0.1	0.1	0.01
EN 60601	Direct current	0.01	0.01	0.01
	Alternating current	0.1	0.1	0.01

See section 14.8 for further limit values.

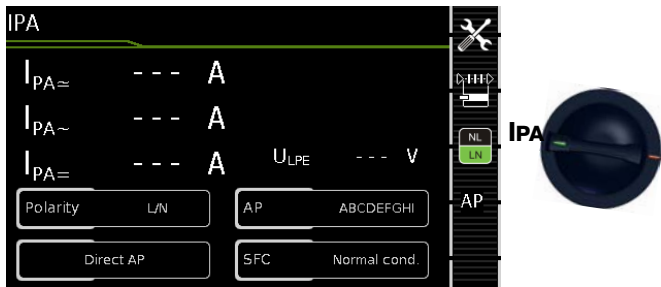
## 8.7.6 Patient Auxiliary Current – IPA



Single measurements, rotary switch level: green

Switch Position	Measurement Type With Mains to Test Socket	Measurement Type Without Mains to Test Socket	Measuring Functions
I <sub>PA</sub>	Direct APP	Perm. conn. APP	$I_{PA\approx}$ Patient auxiliary current, TRMS $I_{PA\sim}$ AC component $I_{PA=}$ DC component $U_{LPE}$ Test voltage

This isn't a leakage current measurement, for which reason reference voltage  $U_{L-PE}$  isn't converted.

### Direct Measuring Method

- Measurement type: direct APP
- DUT mains plug (PC1) connected to test socket
- APPs to APP sockets

### Schematic Diagram

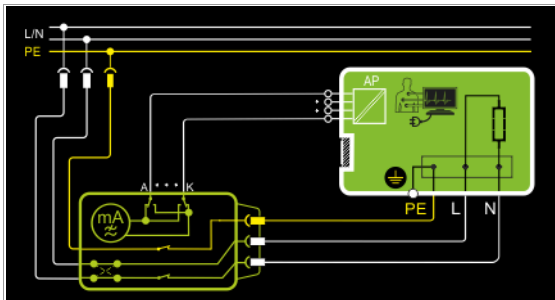

Measurement is conducted from the respectively selected applied part socket to all other applied part sockets after activating **test voltage** and **line voltage**.

Power is supplied to the DUT via the test instrument. The device under test (PC1) is operated with mains power.

The measurements must be performed with mains plug polarity in both directions. Polarity is reversed with the **NL/LN** key.

Measurements are conducted with fixed fault condition **Normal State**.

The measurements have to be conducted under all fault conditions. Selection is made in the measuring parameters menu under **Single Fault**.

### Wiring Diagram

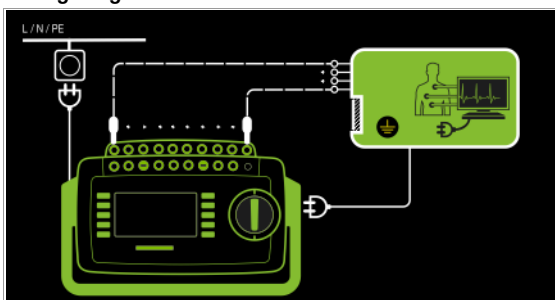

### Direct Measuring Method

- Measurement type: permanent connection APP
- Permanent connection
- APPs to APP sockets

### Schematic Diagram

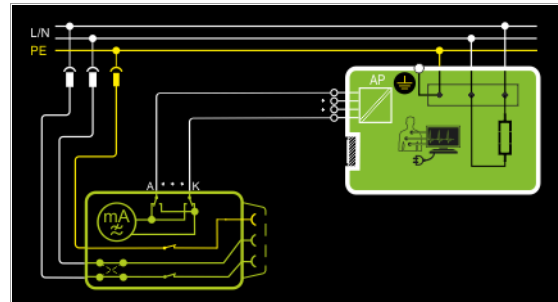

Measurement is conducted from the prospectively selected applied part socket to all other applied part sockets.

Power is supplied to the DUT via the DUT's permanent connection. The device under test (PC1) is operated with mains power.

### Wiring Diagram

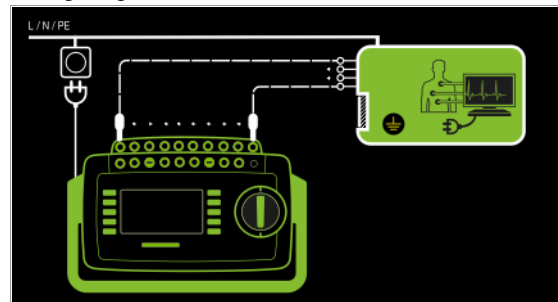

## Setting Measuring Parameters for IPA



Measuring Parameter	Meaning	
<b>Measurement Type</b>		<b>Suitable for DUT Connection via</b>
<b>Direct APP</b>	Direct measurement (via test socket) from the selected APP socket to all others.	Test socket
<b>Perm. conn. APP</b>	Measurement at the permanently installed DUT from the selected APP socket to all others.	Permanent connection
<b>APP – applied parts</b>		
A / B / C / D / E / F / G / H / I / K, each individually (via on/off) to all other APPs		
<b>Single fault (SFC) – only with direct measurement type</b>		
Normal state / N interrupted / PE interrupted		
<b>Polarity</b>		Only with direct measurement type
<b>L/N or N/L</b>	Selection of polarity for mains voltage to the test socket	



### Note

The currently selected **single fault** is displayed on the initial page. In order to change it, it has to be selected and set via the measuring parameters menu.



## Test Sequence

- ⇨ Set the rotary switch to the **I<sub>PA</sub>** position.
- ⇨ Connect the DUT in accordance with the selected measuring type.
- ⇨ Connect the applied parts.
- ⇨ Select the measurement type:
  - By setting the parameters
  - or
  - Directly via the **Measurement Type** key
- ⇨ Select the respective applied parts by setting the utilized sockets to “on” and the unused sockets to “off”.
- ⇨ In the case of **direct measurement P1**, measurement must be performed with mains plug polarity in both directions. Select the respective polarity to this end by pressing the **NL/LN** key.
- ⇨ **Start the test:** press the **START/STOP** key.
- ⇨ After each reconnection to the mains, and as soon as the first test is started, a mains connection test is executed.
- ⇨ **In the case of measurement type direct APP:**
  - ⇨ Acknowledge the warning which indicates that line voltage will be connected to the test socket.
  - ⇨ Switch the device under test on.
  - ⇨ The measured values are displayed. The measured value recording symbol shown at the right appears. Each time this key is pressed, the currently displayed measured value is saved to buffer memory.
  - ⇨ Turn off the device under test.
  - ⇨ **End the test:** press the **START/STOP** key. The save symbol appears (floppy disk showing the number of measured values stored to buffer memory) and prompts you to save the measured values to an ID number.
  - ⇨ Read the measured values and compare them with the table of permissible limit values.
  - ⇨ Press the **ESC** key in order to discard the measured values stored to buffer memory and acknowledge by pressing the key shown at the right.

See limit values in section 14.8.

## 8.8 Probe Voltage – U



### Single measurements, rotary switch level: green

Switch Position	Measurement Type With Mains to Test Socket	Measurement Type Without Mains to Test Socket	Measuring Functions
U		PE - P1	$U_{\sim}$ Probe voltage, RMS $U_{\sim}$ Alternating voltage component $U_{=}$ Direct voltage component
	PE - P1 (with mains)		$U_{\sim}$ Probe voltage, RMS $U_{\sim}$ Alternating voltage component $U_{=}$ Direct voltage component

### Mains to Test Socket

#### Schematic Diagram

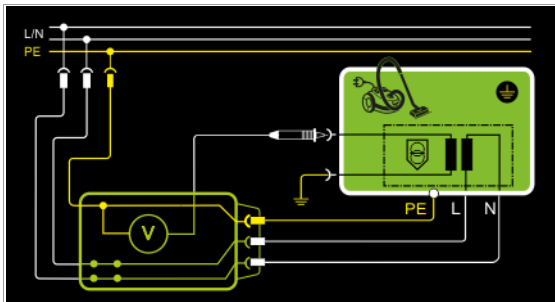

#### Wiring Diagram

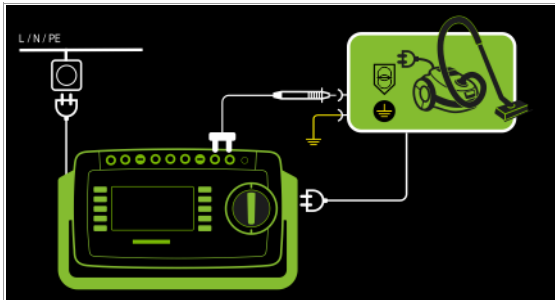

### Permanently connected DUT

#### Schematic Diagram

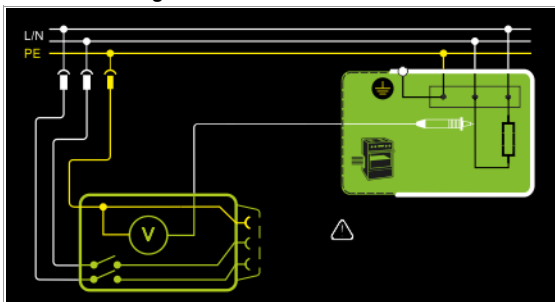

### Wiring Diagram

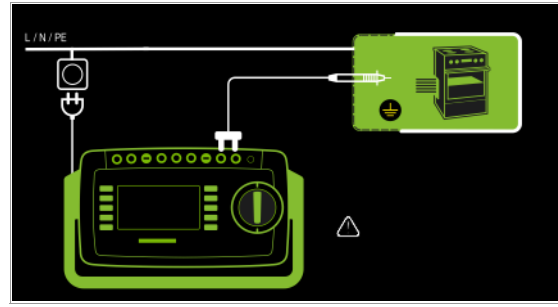

Direct, alternating and pulsating voltages of up to 253 V can be measured. Two connection types are available, one of which has to be selected in the parameters menu.

### Setting Measuring Parameters for $U_{\text{Probe}}$

Measuring Parameter	Meaning	
<b>Measurement Type</b>		Suitable for DUT Connection via
PE-P1	Measurement of voltages with reference to PE, test socket remains voltage-free	Permanent connection
PE-P1 (with mains)	Measurement of voltages with reference to PE, line voltage is applied to the test socket	Test socket
<b>Polarity</b>		Only for PE-P1 (with mains)
L/N or N/L	Selection of polarity for mains voltage to the test socket	

### Test Sequence

- Set the rotary switch to the **U** position.
- Connect the DUT's mains plug to the test instrument's test socket.
- **Start the test:** press the **START/STOP** key.



- **PE-P1 (with mains):** Acknowledge the warning which indicates that line voltage will be connected to the test socket.
- Switch the device under test on.
- Contact the ungrounded output for safety extra-low voltage with test probe P1.
- Polarity can be set via direct selection immediately before measurement is started, without having to switch to the parameters menu.
- The measured values are displayed. The measured value recording symbol shown at the right appears. Each time this key is pressed, the currently displayed measured value is saved to buffer memory.



- Turn off the device under test.
- **End the test:** press the **START/STOP** key. The save symbol appears (floppy disk showing the number of measured values stored to buffer memory) and prompts you to save the measured values to an ID number.
- Press the **ESC** key in order to discard the measured values stored to buffer memory and acknowledge by pressing the key shown at the right.



## 8.9 Measuring Voltage – U (feature I01)

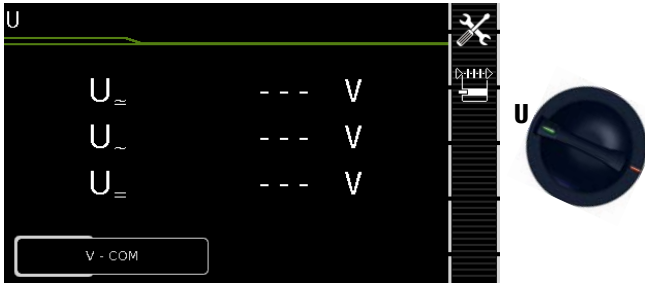

### Single measurements, rotary switch level: green

Switch Position	Measurement Type With Mains to Test Socket	Measurement Type Without Mains to Test Socket	Measuring Functions
U		V – COM	$U_{\sim}$ Measuring voltage, RMS $U_{\sim}$ Alternating voltage component $U_{=}$ Direct voltage component
	V - COM (with mains)		$U_{\sim}$ Measuring voltage, RMS $U_{\sim}$ Alternating voltage component $U_{=}$ Direct voltage component

### Mains to Test Socket

#### Schematic Diagram

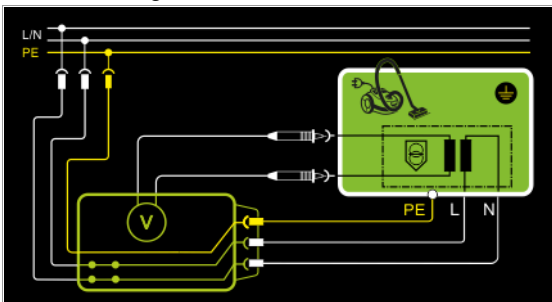

#### Wiring Diagram

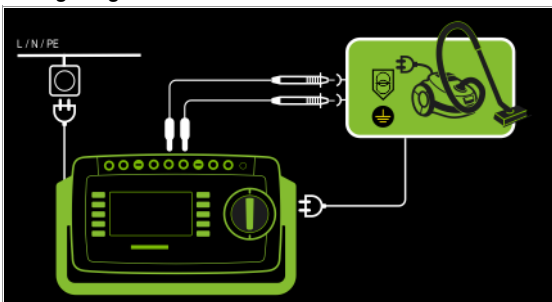

### Permanently connected DUT

#### Schematic Diagram

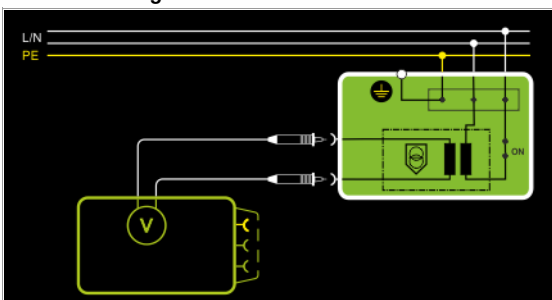

### Wiring Diagram

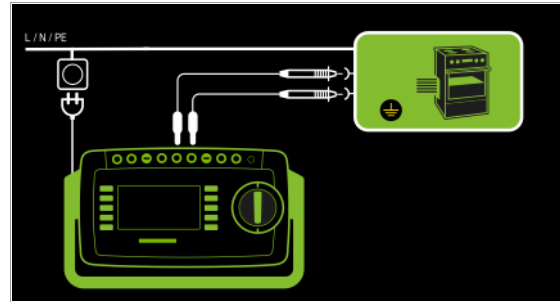

Direct, alternating and pulsating voltages of up to 253 V can be measured between the **V** and **COM** socket terminals.

- Measurements with the voltage measuring input of the volt-meter function (V-COM), electrically isolated from the mains

### Setting Measuring Parameters



Measuring Parameter	Meaning	
<b>Measurement Type</b>		Suitable for DUT Connection via
<b>V – COM</b>	Display: RMS value + AC + DC	Permanent connection
<b>V – COM (with mains)</b>	Display: RMS value + AC + DC; with mains to test socket, e.g. for measuring protective extra-low voltage at power packs	Test socket

### Test Sequence, DUT at Test Socket (e.g. for measuring safety extra-low voltage at power packs or chargers)

- Set the rotary switch to the **U** position.
- Set the parameter to **V – COM (with mains)**.
- Connect the DUT's mains plug to the test instrument's test socket.



#### Attention!

Use only the included, contact-protected KS17-ONE measurement cables when measuring dangerous voltage.

- Connect the DUT's output sockets to the **V** and **COM** sockets, e.g. in order to be able to measure a **safety extra-low voltage** at the DUT's output.
- **Start the test:** press the **START/STOP** key.



- **V-COM (with mains):** Acknowledge the warning which indicates that line voltage will be connected to the test socket.
- Switch the device under test on.
- The measured values are displayed. The measured value recording symbol shown at the right appears. Each time this key is pressed, the currently displayed measured value is saved to buffer memory.
- Turn off the device under test.
- **End the test:** press the **START/STOP** key.



The save symbol appears (floppy disk showing the number of measured values stored to buffer memory) and prompts you to save the measured values to an ID number.



- Press the **ESC** key in order to discard the measured values stored to buffer memory and acknowledge by pressing the key shown at the right.





## 8.10 Function Test – P

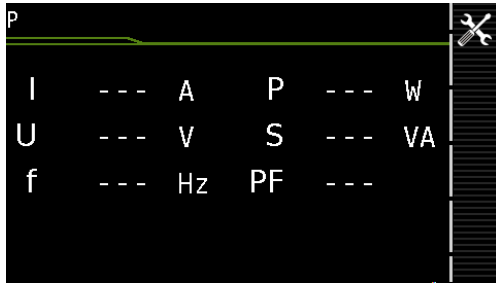

The device under test can be subjected to a function test with mains voltage via the integrated test socket.

The test socket is tested for short-circuiting before switching to line voltage (a statement resulting from the short-circuit test can only be made regarding the DUT itself when a single-phase DUT is being tested).

In addition to testing with the selector switch in the function test position, a function test can also be performed immediately after safety testing has been passed in accordance with the selected standard (not possible for protection class III devices).

### Test Sequence



#### Attention!

The function test may only be performed after the DUT has successfully passed the safety test.



#### Attention!

Refer to the safety precautions on page 7 with regard to **switching power consumers**.



#### Attention!

#### Starting the Function Test

For reasons of safety, the device under test must be switched off before the function test is started. This precaution prevents inadvertent start-up of a DUT which may represent a hazard during operation, e.g. a circular saw or a disc grinder.

#### Ending the Function Test

After completion of the function test, DUTs must be turned off with their own switch – especially devices with relatively high inductivity.

- Set the rotary switch to the **P** position.
- Connect the DUT's mains plug to the test instrument's test socket.
- **Start the test:** press the **START/STOP** key.



- Acknowledge the warning which indicates that line voltage will be connected to the test socket.
- Switch the device under test on.
- The measured values are displayed. The measured value recording symbol shown at the right appears. Each time this key is pressed, the currently displayed measured value is saved to buffer memory.
- Turn off the device under test.



- **End the test:** press the **START/STOP** key. The save symbol appears (floppy disk showing the number of measured values stored to buffer memory) and prompts you to save the measured values to an ID number.
- Press the **ESC** key in order to discard the measured values stored to buffer memory and acknowledge by pressing the key shown at the right.



Single measurements, rotary switch level: green			
Switch Position	Measuring Functions	Measurement Type With Mains to Test Socket	
P	<b>Function test at the test socket</b>		
	I	Current between L and N	Selection of polarity for mains voltage
	U	Voltage between L and N	
	f	Frequency	
	P	Active power	
	S	Apparent power	
PF	Power factor		

### Schematic Diagram

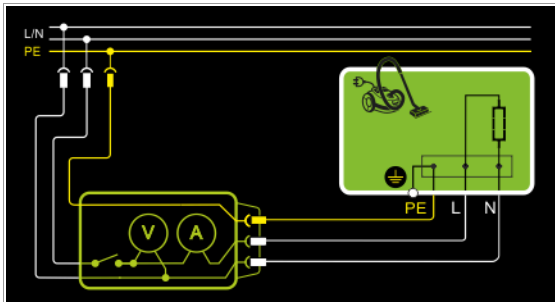

### Wiring Diagram

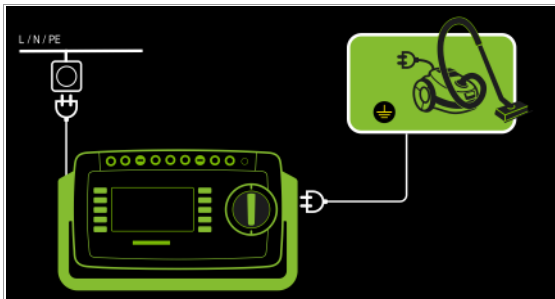

### Setting Measuring Parameters for P



Measuring Parameter	Meaning
<b>Polarity</b>	
LN	Phase L – neutral conductor N
NL	Neutral conductor N – phase L

### The following connection types are possible:

- Test socket
- CEE adapter (only for connection via single-phase CEE or "caravan socket")
- AT3 adapter (AT3-IIIE, AT3-IIS, AT3-IIS32)
- AT16DI/AT32DI



#### Note

These or similar adapters can be used for the function test (initial start-up of the DUT), but measurement of apparent and active power, power factor and current consumption is only possible when the DUT is directly connected to the test socket or via the CEE adapter (single-phase CEE socket only).

## 8.11 Testing Extension Cords for Correct Function – EL1

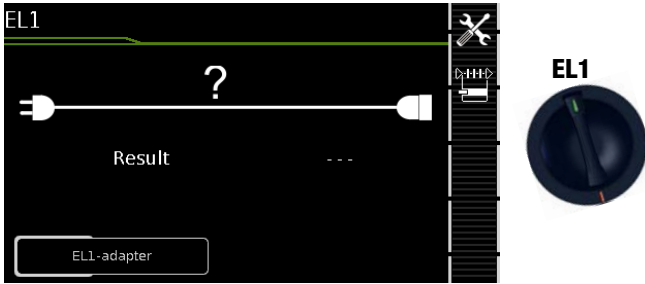

### Single measurements, rotary switch level: green

Switch Position	Measuring Functions	Measurement Type Without Mains to Test Socket
EL1	Extension cord test with adapter for single or 3-phase extension cords for testing for: <ul style="list-style-type: none"> <li>– Continuity</li> <li>– Short-circuit</li> <li>– Incorrect polarity (reversed wires *)</li> </ul>	EL1 adapter AT3-III-E adapter VL2E adapter

\* No checking for reversed polarity takes place when the EL1 adapter is used.

Testing for	Continuity L(1/2/3), N	Short-circuiting between: L(1/2/3), N	Polarity reversal / clockwise phase sequence
EL1 adapter	X	X	—
VL2E adapter	X	X	X
AT3-III-E adapter	X	X	X



### Attention!

This function permits an evaluation of the continuity of the active conductors L(1, 2, 3) and N of an extension cord. The PE conductor isn't tested in this case.

### Measurement at Single-Phase Extension Cords with EL1

#### Schematic Diagram

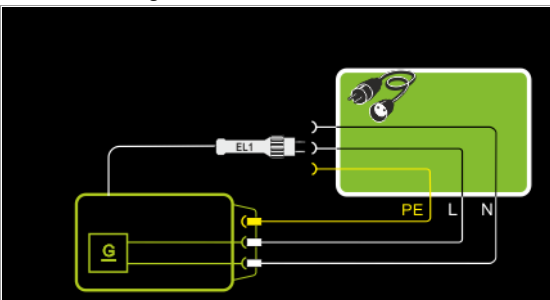

#### Wiring Diagram

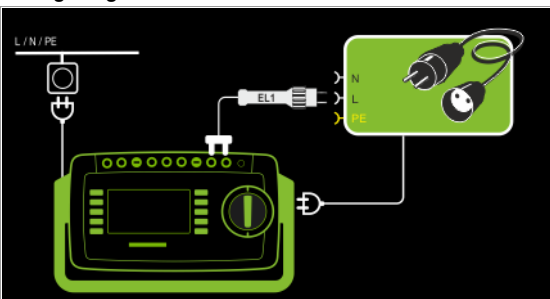

### Measurement at Single and 3-Phase Extension Cords with VL2E

#### Schematic Diagram

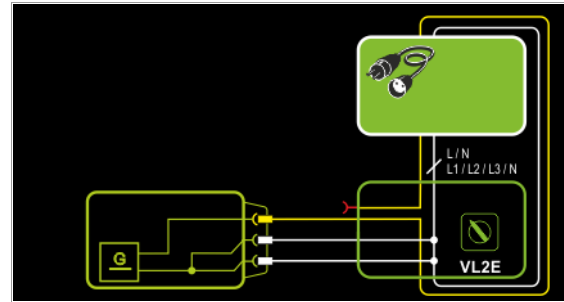

#### Wiring Diagram

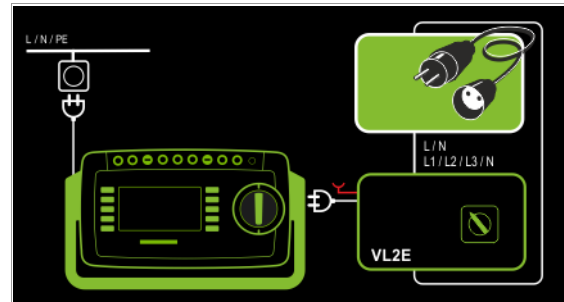

### Measurement at Single and 3-Phase Extension Cords with AT3-III-E

#### Schematic Diagram

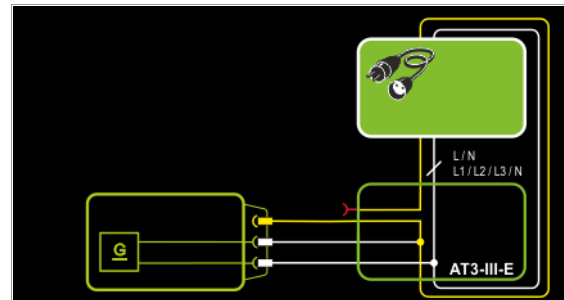

#### Wiring Diagram

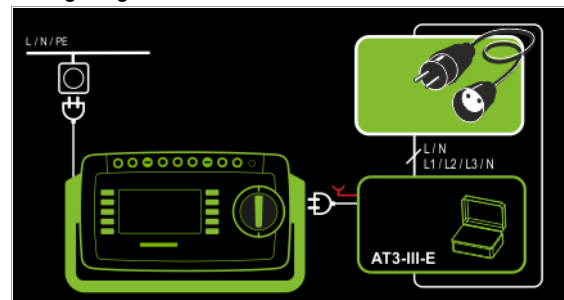

## Setting Measuring Parameters



Testing for	Continuity L(1/2/3), N	Short-circuiting between: L(1/2/3), N	Polarity reversal / clockwise phase sequence
EL1 adapter	X	X	—
VL2E adapter	X	X	X
AT3-III E adapter	X	X	X

See corresponding single measurements for the testing of RPE and RINS.



### Note

See section 10, "Test Sequences in Accordance with Standards" (switch setting A8) with regard to testing extension cords per DIN VDE 0701-0702, for which RPE and RINS are measured.



### Attention!

If the EL1 continuity test is conducted for an extension cord in combination with a "travel adapter", results provided by the test instrument indicating the correctness of the extension cord's polarity cannot be relied upon!





### Note

**In the case of cables with indicator lamp** (usually a glow lamp in the switch), the results of the continuity test for L and N may be distorted due to additional resistance caused by the glow lamp.

In case of doubt, perform a continuity test for L and N by means of resistance measurement (R-PE or R-INS): R-PE between probe 1 and probe 2.

## Test Sequence with EL1 Adapter

- ⇨ Set the rotary switch to the **EL1** position.
- ⇨ Select the **EL1 adapter** connection type directly via the key shown at the right. 
- ⇨ Connect the EL1 adapter to the P1 sockets at the test instrument.
- ⇨ Connect the plug at the end of the extension cord to the test socket.
- ⇨ Connect the coupling socket at the end of the extension cord to the plug at the EL1 adapter.
- ⇨ **Start the test:** press the **START/STOP** key. 

- ⇨ The measured values are displayed. The measured value recording symbol shown at the right appears. Each time this key is pressed, the currently displayed measured value is saved to buffer memory. 

- ⇨ **End the test:** press the **START/STOP** key. The save symbol appears (floppy disk showing the number of measured values stored to buffer memory) and prompts you to save the measured values to an ID number.   

- ⇨ Press the **ESC** key in order to discard the measured values stored to buffer memory and acknowledge by pressing the key shown at the right. 

## Test Sequence with VL2E Adapter

- ⇨ Set the rotary switch to the **EL1** position.
- ⇨ Select the **VL2E adapter** connection type directly via the key shown at the right. 
- ⇨ Connect the cable from the VL2E adapter to the test socket at the SECUTEST....
- ⇨ Connect the extension cord's plug and socket to the VL2E adapter.



- ⇨ **Start the test:** press the **START/STOP** key. 

- ⇨ Set the rotary selector switch on the VL2E adapter to position 2 and retain this position. The measured values are displayed.



### Note

The test instrument only indicates whether or not the cable is **OK** or **not OK**. In the case of "not OK", the inspector has to determine whether or not an interruption or a short-circuit is involved on his own by means of further measurements.

- ⇨ **End the test:** press the **START/STOP** key. The save symbol appears (floppy disk showing the number of measured values stored to buffer memory) and prompts you to save the measured values to an ID number.   

- ⇨ Press the **ESC** key in order to discard the measured values stored to buffer memory and acknowledge by pressing the key shown at the right. 

## Test Sequence with AT3-III E Adapter



### Attention!

Please observe the operating instructions for the AT3-III E regarding correct connection of the test adapter and the device under test, as well as peculiarities involved in the test sequence.

## 9 Special Functions – EXTRA

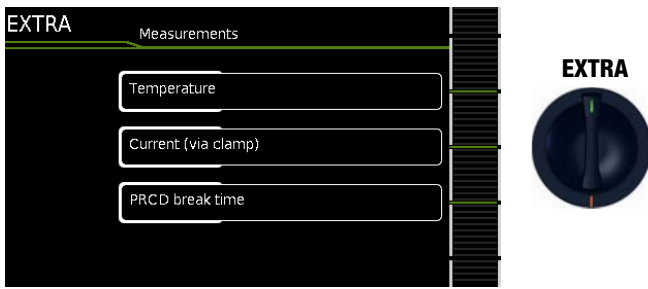

Single measurements, <i>rotary switch level: green</i>		
Switch Position	Measuring Functions	Measurement Type
EXTRA	ta – PRCD time to trip for 10/30 mA PRCD	
	Temp. – temperature	V-COM
	IZ – current clamp	V-COM

The rotary switch's **EXTRA** position includes additional functions.

- ⇒ Select the desired measuring function.

## Measuring Time to Trip for RCDs of the Type PRCD – $t_A$

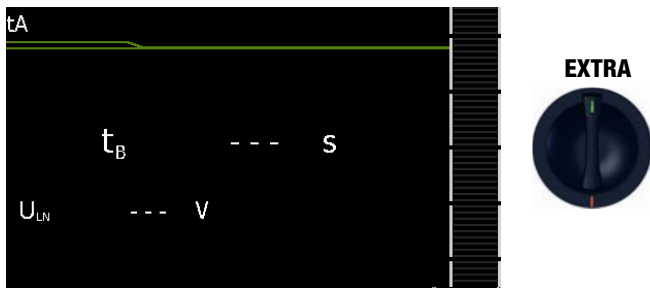

### Single measurements, rotary switch level: green

Switch Position	Measuring Functions	Measurement Type With Mains to Test Socket
$t_A$	$t_a$ PRCD time to trip for 10/30 mA PRCD	
	$U_{LN}$ Line voltage at the test socket	

## Test Sequence

- Set the rotary switch to the  $t_A$  position.
- Plug the PRCD into the test socket at the test instrument and connect the test probe to P1.

- Start the test:** press the **START/STOP** key.



- Acknowledge the warning which indicates that line voltage will be connected to the test socket.



Execute the following steps when prompted to do so:



### Note

Please note that test probe P1 is in continuous contact with the phase conductor from the point in time at which the PRCD is plugged in until it trips. Premature disconnection of the test probe may result in erroneous measured values.

## Schematic Diagram

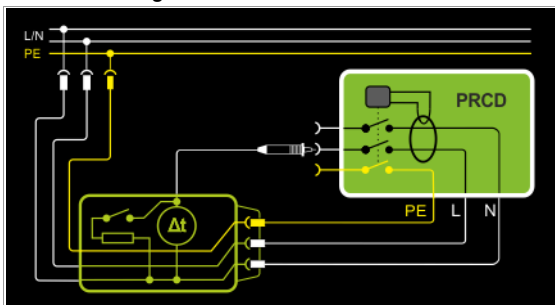

## Wiring Diagram

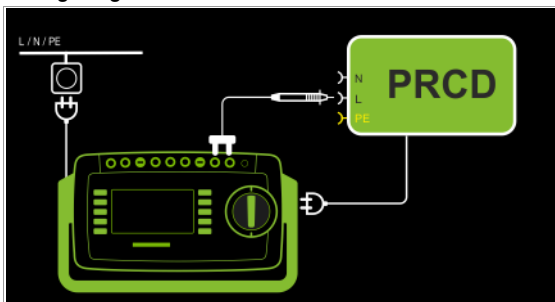

- After each reconnection to the mains, and as soon as the first test is started, a mains connection test is executed.
- If the probe test has revealed that probe P1 was not connected: connect probe P1 as described above.
- Switch the PRCD on after connection to line voltage (e.g. reset button on PRCD).
- Contact neutral conductor L at the PRCD with test probe P1 (ascertain by trial and error if necessary).
- The test is automatically ended and time to trip is displayed after the PRCD is tripped.
- The save symbol appears and prompts you to save the measured values to an ID number.
- Press the **ESC** key in order to discard the measured values stored to buffer memory and acknowledge by pressing the key shown at the right.



## Definition

According to DIN VDE 0100-600:2008, verification must be provided that RCCBs are tripped within the time period specified in DIN VDE 0100-410.

**PRCD** Portable residual current device

## Applications

The PRCD under test is plugged into the test socket at the test instrument. The PRCD's phase conductor must be contacted with test probe P1 in order to trip the PRCD.



### Note

Testing of PRCDs (test sequences and time to trip) is only possible for DUTs with a nominal voltage of 230 V.



### Note

Measurement of time to trip isn't possible in IT systems.

## Measurements with Temperature Sensor (feature F01)

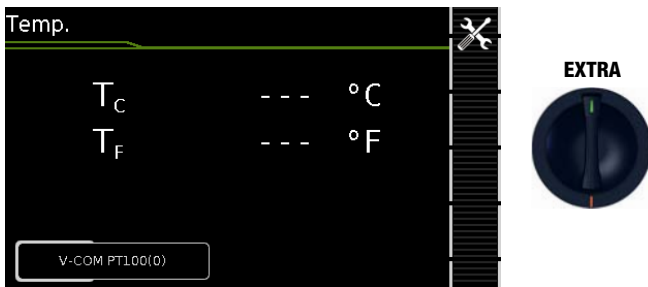

Temperature measurement is conducted with either a Pt100 or a Pt1000 temperature sensor – the sensor type is automatically detected internally.



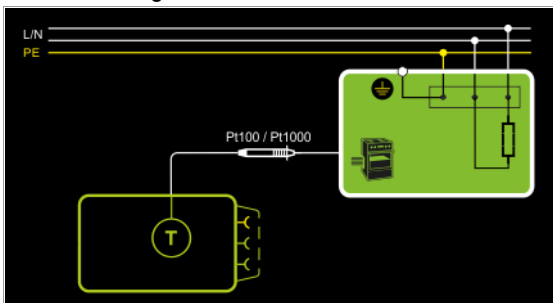

### Schematic Diagram

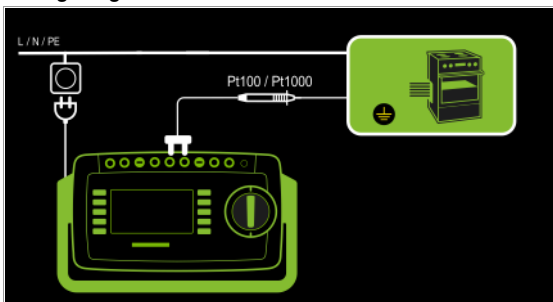

### Wiring Diagram



### Test Sequence with Temperature Sensor

- ⇨ Set the rotary switch to the **EXTRA** position.
- ⇨ Select the **Temperature** measurement type:
- ⇨ Connect the temperature sensor's plug to the V-COM sockets at the test instrument.
- ⇨ Contact the device under test.
- ⇨ **Start the test:** press the **START/STOP** key. 
- ⇨ The measured values are displayed. The measured value recording symbol shown at the right appears. Each time this key is pressed, the currently displayed measured value is saved to buffer memory. 
- ⇨ **End the test:** press the **START/STOP** key. The save symbol appears (floppy disk showing the number of measured values stored to buffer memory) and prompts you to save the measured values to an ID number.   

- ⇨ Press the **ESC** key in order to discard the measured values stored to buffer memory and acknowledge by pressing the key shown at the right. 

## Measurements with Current Clamp Sensor (feature F01)

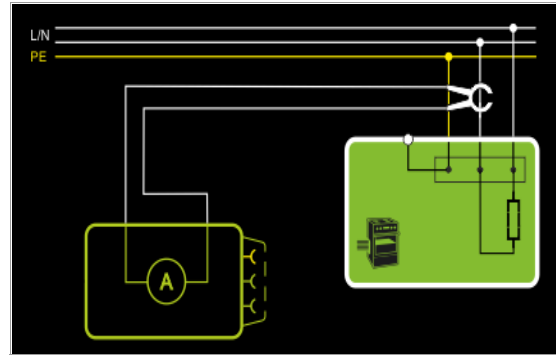

Current clamp measurement is possible in this case independent of measuring functions  $R_{PE}$ ,  $I_{PE}$  and  $I_E$ , e.g. for measuring current at permanently installed devices.

## Schematic Diagram – Permanent Connection



The current of a permanently connected consuming device can be measured with the current clamp sensor.

## Schematic Diagram – Mains to Test Socket

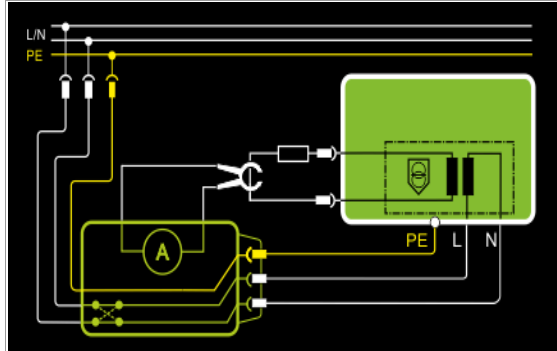

The current of a consuming device connected to the extra-low voltage output can be measured with the current clamp sensor.

## Wiring Diagram – Permanent Connection

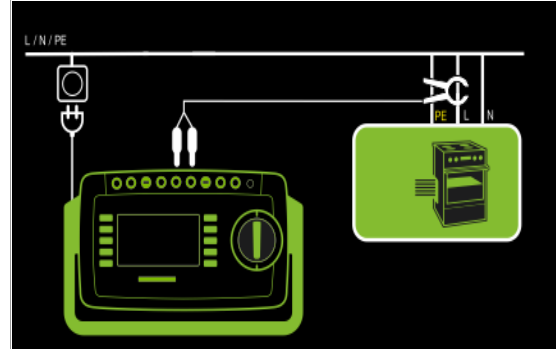

## Wiring Diagram – Mains to Test Socket

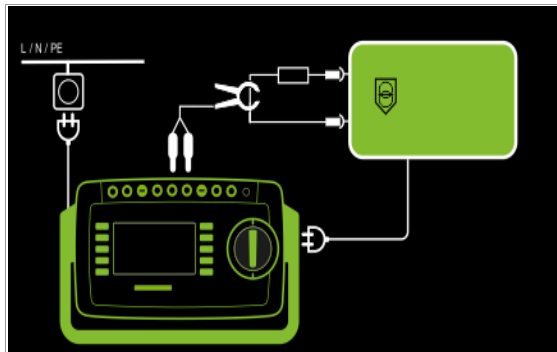







## Setting Measuring Parameters for a Current Clamp Sensor



Measuring Parameter	Meaning	
<b>Measurement Type</b>		<b>Suitable for DUT Connection via</b>
V – COM	Display: A AC	Permanent connection
V – COM (with mains)	Display: A AC: with mains to test socket, e.g. for measuring protective extra-low voltage at power packs	Test socket
<b>Polarity – only for PE-P1 (with mains)</b>		
L/N or N/L	Selection of polarity for mains voltage to the test socket	
<b>Clamp factor</b>		
<b>At tester</b>	<b>Clamp transformation ratio</b>	<b>Suitable clamps</b>
1 V : 1000 A (1 : 1000)	1 mV / 1 A	WZ12C, Z3512A, METRAFLEX 3000
1 V : 100 A (1 : 100)	10 mV / 1 A	WZ11B, Z3512A, METRAFLEX 3000/300M
1 V : 10 A (1 : 10)	100 mV / 1 A	WZ12B, WZ11B, Z3512A, METRAFLEX 3000/300M
1 mV : 1 mA (1 : 1)	1000 mV / 1 A	WZ12C, Z3512A, METRAFLEX 300M
10 mV : 1 mA (10 : 1)		
100 mV : 1 mA (100 : 1)	100 mV : 1 mA	<b>SECUTEST CLIP</b>
1 V : 1 mA (1000 : 1)		



## Test Sequence with Current Clamp Sensor

- ⇨ Set the rotary switch to the **EXTRA** position.
- ⇨ Select the **Current (via clamp)** measuring function.
- ⇨ Set the clamp factor at the current clamp sensor.
- ⇨ **Clamp factor:** Set clamp factor at the test instrument to the same value as at the current clamp sensor. 
- ⇨ Connect the current clamp to the V-COM sockets at the test instrument.
- ⇨ Enclose the consuming device's cable with the current clamp sensor as shown in the schematic diagrams.
- ⇨ **Start the test:** press the **START/STOP** key. 
- ⇨ The measured values are displayed. The measured value recording symbol shown at the right appears. Each time this key is pressed, the currently displayed measured value is saved to buffer memory. 
- ⇨ **End the test:** press the **START/STOP** key. The save symbol appears (floppy disk showing the number of measured values stored to buffer memory) and prompts you to save the measured values to an ID number.   

- ⇨ Press the **ESC** key in order to discard the measured values stored to buffer memory and acknowledge by pressing the key shown at the right. 

## Setting Measuring Range at the Clamp and Parameters at the Test Instrument

Test Instrument	Current Clamp Sensor		Test Instrument
Clamp Factor	Transformation Ratio (switch *)	Measuring Range	Display Range with Clamp
<b>WZ12C</b>			
<b>1000 mV : 1 A</b>	1000 mV : 1 A	1 mA ... <b>15 A</b>	0 A ... 300 A
<b>1 mV : 1 A</b>	1 mV : 1 A	1 A ... <b>150 A</b>	1.0 A ... 300 A
<b>WZ12B</b>			
<b>100 mV : 1 A</b>	100 mV : 1 A	10 mA ... <b>100 A</b>	0 A ... 300 A
<b>WZ11B</b>			
<b>100 mV : 1 A</b>	100 mV : 1 A	0.5 A ... <b>20 A</b>	0 A ... 300 A
<b>10 mV : 1 A</b>	10 mV : 1 A	5 A ... <b>200 A</b>	0 A ... 300 A
<b>Z3512A</b>			
<b>1000 mV : 1 A</b>	1000 mV : 1 A	0.001 A ... <b>1 A</b>	0 A ... 300 A
<b>100 mV : 1 A</b>	100 mV : 1 A	0.01 A ... <b>10 A</b>	0 A ... 300 A
<b>10 mV : 1 A</b>	10 mV : 1 A	0.1 A ... <b>100 A</b>	0 A ... 300 A
<b>1 mV : 1 A</b>	1 mV : 1 A	1 A ... 1000 A	0 A ... <b>300 A</b>
<b>METRAFLEX 3000</b>			
<b>100 mV : 1 A</b>	100 mV : 1 A	0.01 A ... <b>30 A</b>	0 A ... 300 A
<b>10 mV : 1 A</b>	10 mV : 1 A	0.1 A ... 300 A	0 A ... <b>300 A</b>
<b>1 mV : 1 A</b>	1 mV : 1 A	1 A ... 3000 A	0 A ... <b>300 A</b>
<b>METRAFLEX 300M</b>			
<b>1000 mV : 1 A</b>	1000 mV : 1 A	0.001 A ... <b>3 A</b>	0 A ... 300 A
<b>100 mV : 1 A</b>	100 mV : 1 A	0.01 A ... <b>30 A</b>	0 A ... 300 A
<b>10 mV : 1 A</b>	10 mV : 1 A	0.1 A ... 300 A	0 A ... <b>300 A</b>
<b>100 mV : 1 mA</b>	<b>SECUTEST CLIP</b>		
	100 mV : 1 mA	0.1 ... <b>25 mA</b>	0.01 mA ... 3.00 A

# 10 Test Sequences

## Default Settings

Automatic test sequences, rotary switch level: orange					
Switch Setting	Standard / Test Sequence	Measurement Type	Connection	Protection class	Freely Configurable Depending on Selected Configuration (protection class, type of applied part)
<b>Preconfigured (freely adjustable) test sequences</b>					
A1	IEC 62353 <sup>1</sup>	Passive	Test socket, 1 group BF APPs A-K	PC I	Short-circuit test – visual inspection – RPE – RINS PC I – RINS APP – RINS LN <> APP F – RINS PE <> APP F – IE PC I – IT Alt. <sup>4</sup> – IA BF – function test
A2	IEC 62353 <sup>1</sup>	Passive	Test socket, 1 group BF APPs A-K	PC II	Short-circuit test – visual inspection – RINS PC II – RINS APP – RINS LN <> APP F – RINS PE <> APP F – IE PC I – IT Alt. <sup>4</sup> – IA BF – function test
A3	IEC 62353 <sup>1</sup>	Passive	Test socket, 1 group BF APPs A-K	PC I + PC II	Short-circuit test – visual inspection – RPE – RINS PC I – RINS PC II – RINS APP – RINS LN <> APP F – RINS PE <> APP F – IE PC I – IT Alt. <sup>4</sup> – IA BF – function test
A4	IEC 62353 <sup>1</sup>	Active	Auto-detection, 1 group BF APPs A-K	PC I	Short-circuit test – visual inspection – RPE – RINS PC I – RINS APP – RINS LN <> APP F – RINS PE <> APP F – IE NL PC I – IT NL <sup>4</sup> – IA NL BF – IE LN PC I – IT LN <sup>4</sup> – IA LN BF – function test
A5	IEC 62353 <sup>1</sup>	Active	Auto-detection, 1 group BF APPs A-K	PC II	Short-circuit test – visual inspection – RINS PC II – RINS APP – RINS LN <> APP F – RINS PE <> APP F – IE NL PC I – IT NL <sup>4</sup> – IA NL BF – IE LN PC I – IT LN <sup>4</sup> – IA LN BF – function test
A6	IEC 62353 <sup>1</sup>	Active	Auto-detection, 1 group BF APPs A-K	PC I + PC II	Short-circuit test – visual inspection – RPE – RINS PC I – RINS PC II – RINS APP – RINS LN <> APP F – RINS PE <> APP F – IE NL PC I – IT NL <sup>4</sup> – IA NL BF – IE LN PC I – IT LN <sup>4</sup> – IA LN BF – function test
A7 KA00	VDE 0701-0702 ÖVE E 8701 SNR 462638 <sup>1</sup>	Passive	Auto-detection	PC I + PC II	Short-circuit test – visual inspection – RPE – RINS PC I – RINS PC II <sup>4</sup> – RINS APP – IPE NL – IT NL <sup>4</sup> – IPE LN – IT LN <sup>4</sup> – function test
A8 KA00	VDE 0701-0702 ÖVE E 8701 SNR 462638 <sup>1</sup>	Active	Auto-detection	PC I + PC II	Short-circuit test – visual inspection – RPE – RINS PC I – RINS PC II <sup>4</sup> – RINS APP – IPE NL – IT NL <sup>4</sup> – IPE LN – IT LN <sup>4</sup> – function test
A9 KA00	VDE 0701-0702 ÖVE E 8701-EDV SNR 462638-EDV <sup>1</sup>	Active	Auto-detection	PC I + PC II	Short-circuit test – visual inspection – RPE – IPE NL – IT NL <sup>4</sup> – IPE LN – IT LN <sup>4</sup> – function test
A7 KA01	IEC 60601 3 <sup>rd</sup> edition <sup>1</sup>	Active	Auto-detection, 1 group BF APPs A-K	PC I	Short-circuit test – visual inspection – RPE – RINS PC I <sup>2</sup> – RINS APPs <sup>2</sup> – IPE – IT – IP – function test
A8 KA01	IEC 60601 3 <sup>rd</sup> edition <sup>1</sup>	Active	Auto-detection, 1 group BF APPs A-K	PC II	Short-circuit test – visual inspection – RPE – RINS PC I <sup>2</sup> – RINS PC II <sup>2</sup> – RINS APPs <sup>2</sup> – IPE <sup>3</sup> – IT <sup>3</sup> – IP <sup>3</sup> – function test
A9 KA01	IEC 60601 3 <sup>rd</sup> edition <sup>1</sup>	Active	Auto-detection, 1 group BF APPs A-E 1 group CF APPs F-K	PC I + PC II	Short-circuit test – visual inspection – RPE – RINS PC I <sup>2</sup> – RINS PC II <sup>2</sup> – RINS APPs <sup>2</sup> – IPE <sup>3</sup> – IT <sup>3</sup> – IP <sup>3</sup> – function test

<sup>1</sup> Depending on the setting for the “Measuring Sequences” parameter in SETUP

<sup>2</sup> RINS is deactivated as a default setting – can be activated via the sequence parameters.

<sup>3</sup> Measurement under special test conditions deactivated as a default setting – can be activated via the sequence parameters.

<sup>4</sup> Additional testing of conductive/metallic parts which are not connected to the protective conductor

**Auto-detection** = parameter for automatic detection of the DUT’s connection (see page 78)

### 10.1 General

If the same sequence of single tests will be run frequently (one after the other with subsequent report generation), for example as specified in the standards, it’s advisable to make use of test sequences (also called measuring sequences).

Limit values have been entered for test sequences in accordance with the standards. And thus a go/no-go evaluation takes place during measurement based on worst-case assessment. If the momentary measured value is displayed in green, it lies within the limit values specified in the standard. If the measured value is red, it doesn’t fulfill the requirements set forth in the standard.



#### Note

The go/no-go evaluation of the measured values is performed with greater accuracy than the value which appears at the display, which may lead to the fact that, due to the missing decimal places, a measured value which appears at the display may seem to correspond exactly to the limit value although it’s highlighted in red (as a limit value violation) due to the places to the right of the decimal point.

If the measured value is orange, further entries are required after the test step (e.g. cable length), which are decisive as to whether or not the test has been passed. Even if the DUT fails just one single measurement, the test sequence is aborted and testing in accordance with the selected standard is failed.

Automatic test sequences are run in rotary switch positions A1 through A9.

Test sequences A1 through A9 are preconfigured at the factory. We recommend assigning frequently used test sequences to A1 through A9 for which parameters often need to be adjusted.

The measurements are evaluated automatically by the test instrument. Evaluation is based on the worst-case and, depending on settings, in consideration of measuring uncertainty.

Settings for the test sequences can be entered to the test instrument in two different ways:

- **SETUP switch position:** general settings can be entered which apply to all test sequences (regardless of the respectively selected standard).
- **Switch positions A1 through A9:** classification and sequence parameters can be entered which only apply to the selected switch position.

#### Test Sequences in AUTO Rotary Switch Positions (A1 to A9)

The following test sequences are included in the test instrument’s rotary switch positions as a standard feature:

- **DIN VDE 0701-0702**  
Periodic testing and testing after repair and modification of electrical equipment
- **IEC 62353**  
Medical electrical equipment – Recurrent test and test after repair of medical electrical equipment (applied parts with test probe P1)
- **IEC 60601 (3<sup>rd</sup> edition)**  
Medical electrical equipment  
– Part 1: General requirements for basic safety and essential performance

The individual sequences are selected with the softkeys.

## User-Defined Test Sequences

Up to 24 customer-specific (user-defined) test sequences can be saved to the test instrument and assigned to the AUTO rotary switch positions, i.e. A1 to A9. These sequences are created at the PC with the help of **IZYTRONIQ** software. The measurements and parameters available in your SECULIFE version are loaded from the test instrument and made available in the PC software for this purpose. Finally, the created test sequence can be loaded directly to the SECULIFE (prerequisite: database extension, feature KB01, "Z853R – SECUTEST DB+") and saved to the computer as an XML file. As a rule, customer-specific (user-defined) test sequences are identified with a preceding asterisk (\*) at the test instrument's user interface.

## 10.2 User-Defined Test Sequences / Remote Control (only with feature KB01, "Z853R – SECUTEST DB+")

### 10.2.1 General

When creating user-defined test sequences, the author of the test sequence can define and configure individual test steps himself, and specify the order in which they're run.

With the help of **IZYTRONIQ** PC software, test sequences can be created at the PC and transferred to the test instrument via a USB port.



#### Note

Up to 1200 test steps can be distributed to as many as 24 test sequences and saved to memory at the test instrument.

Similar options are available to the user when the test instrument is remote controlled (e.g. via **IZYTRONIQ** IZY remote test sequences).

Some of the test steps necessitate advance testing in the form of inspections or test instructions, for example so that the inspector has enough time to contact the respective location with the probe at the point in time of test execution, or to set the DUT to the appropriate state.

If user-created test sequences are created and/or used, or in the case of remote control of the test instrument, the creator of the test sequences or the user/inspector assumes responsibility for standards-compliant test steps and execution of advance tests in the correct order.



#### Attention!

If you change or shorten the default test sequences for the respective standards, the danger exists that they will no longer be compliant and will thus become invalid as verification of operating safety in accordance with DGUV regulation 3 or BetrSichV, or will no longer fulfil these standards.

### 10.2.2 Testing of Probe Connection P1 and Probe Fuse P1

If probe P1 is used in a test sequence, a "Probe Test" step with "Probe: Probe Connection P1" must be included in the respective test sequence. Background: In addition to assuring that a probe is connected to probe connection P1, the probe test at connection P1 also determines whether or not the probe's fuse link is intact.



#### Attention!

If the fuse at test probe P1 is defective, all subsequent measurements using this measuring path are incorrectly evaluated as good!

### 10.2.3 APP Fuse Test

If the APP sockets are used during a test sequence (regardless of whether the connections are used for measurement or in order to implement the "APP > PE" test condition [applied part to ground]), the "APP fuse test" step must be additionally conducted. This test step ensures that both APP fuses are intact.



#### Attention!

If measurements are conducted for which the APP connections are used, and if one or both of the APP fuses are defective, incorrect measured values may result.

### 10.3 General Settings (Setup: auto measurements parameter)

The following settings can be entered for all test sequences in the **SETUP** switch position on menu page 1/3 under the **auto measurements** parameter (see section 4.3):

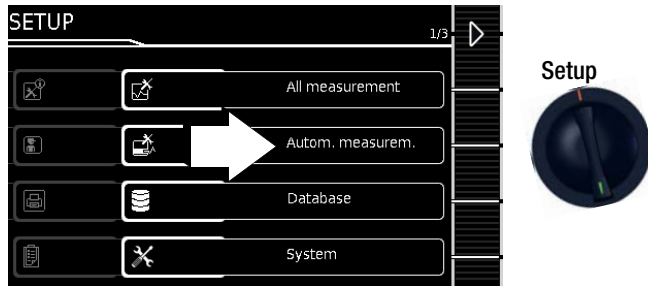

#### Automatic Measurements (1/3)

##### ❑ At the End of the Sequence

At the end of a sequence, either the save symbol appears in order to prompt storage ("memory screen" parameter), or the results list ("results list" parameter) is displayed.

##### ❑ Considering Measuring Uncertainty

If **Yes** is selected, measuring uncertainty is taken into consideration when the measurement results are displayed. The final result which appears at the display is downgraded by an amount equal to measuring uncertainty.

##### ❑ Auto Measuring Point

If **Yes** is selected, the test instrument detects whether or not the protective conductor is contacted with the probe during the protective conductor resistance measurement of an automatic test sequence and automatically starts recording a new measuring point. Statuses are indicated by various, continuous acoustic signals. The protective conductor test can thus be conducted without using the keys on the instrument.

##### Note

The "Auto Measuring Point" function is only activated during test steps of the "multiple measurement" type. If you want to use this function ...

- in the case of integrated test sequences: Make sure that the "multiple measurement" test parameter (see page 54) is selected for the RPE test step.
- in the case of user-defined test sequences (only with database extension, feature KB01, "Z853R – SECUTEST DB+"): make sure that the RPE test step has been entered to the sequence as a "multiple measurement".

#### Automatic Measurements (2/3)

##### ❑ Initial Window Style

Selection can be made here between a tree view and a detail view for the first page of the test sequence (see section 10.4).

##### ❑ Limit Value Mode

If you want to use only the limit values specified in the standards to evaluate the measurements, set the parameter to **Normal**.

When set to **Expert**, the **LIMIT** softkey appears next to the "measurement failed" popup if the measurement has not been passed. This key makes it possible to enter a user-defined limit value (as a rule a limit value specified by the manufacturer which deviates from the standard), in order to allow the test to be passed under these new conditions.

##### Note

Entry of a user defined limit value isn't possible if "Continue" is selected for the "Limit Violation" option.

##### ❑ Limit Value Violation (only with feature KD01, "Z853S – SECUTEST DB COMFORT")

With its **"Try Again"** operating mode, the test instrument makes it possible to immediately restart the failed test step and repeat the measurement in the event that a limit value is violated.

In the **"Continue"** mode, the test instrument doesn't terminate the test sequence in the event of a limit value of violation, and instead continues testing despite any individual steps which have failed.

##### Note

If a limit value violation occurs during the test sequence, the respective test step designation appears in red in the header for all following test steps, so that it's already made apparent during the test sequence that a limit value violation has occurred during one of the previous test steps, and that the device under test will not pass testing.

#### Automatic Measurements (3/3)

##### ❑ Measuring Sequences

The following standards can be selected here:  
VDE, OVE (Dutch version: NEN)

The instrument is restarted if the setting for "Measuring Sequences" has been changed and the "Auto Measurements" menu is exited.

##### Note

The test instrument must be restarted after changing the measuring sequences.  
Database structure and content remain unchanged.

##### ❑ Autostore (feature KD01, "Z853S – SECUTEST DB COMFORT")

If this function is activated ("on"), the test results for the automatic test sequence are immediately saved under the test object (= device or ME equipment (medical electrical equipment)) which is currently selected in the database.

If you haven't yet selected a test object in memory management (MEM key), a message appears informing you that automatic storage of the current test isn't possible.

You're prompted to enter an object ID via the scanner or the softkeys, or to select one from the database (MEM key). In this case you have to save the test manually to the database via the "Save" softkey.

##### ❑ Skip steps

Here you can configure whether or not the user is allowed to skip test steps **during** a test sequence ("on").

This does **not** apply to inspection test steps that can be omitted (which have no relevance with regard to the standard)!

## Meaning of Symbols in the User Interface – Test Sequence

Sym- bol	Softkey Variants, Test Sequence
	Test for Protection Class I Devices Exposed, conductive parts are connected to the protective conductor so that they're not charged with voltage if the basic insulation should fail.
	Test for Protection Class II Devices These devices are equipped with double insulation or reinforced insulation.
	Test for Protection Class III Devices These devices are supplied with safety extra-low voltage (SELV). Beyond this, no voltages are generated which exceed SELV.
	Type B applied parts (body) (see also section 14.7.2)
	Type BF applied parts (body float) (see also section 14.7.2)
	Type CF applied parts (cardiac float) (see also section 14.7.2)
	"Applied part type" key: A group of applied parts can be assigned to a type (B, BF or CF). Prerequisite: The classification parameter and then the applied parts menu have been accessed, and a group has been created via the "Expand Group" key.
	"Expand Group" key: Each time the key is activated, a further applied part socket is assigned to the group. Prerequisite: The classification parameter and then the applied parts menu have been accessed.
	"Reduce Group" key: Each time the key is activated, an applied part socket is removed from the group. Prerequisite: The classification parameter and then the applied parts menu have been accessed.
	"Next Group" key: Each time the key is activated, the input frame jumps to a position which has not yet been assigned or to an already assigned position, depending on whether you want to create a new group or edit an existing group. Prerequisites: The classification parameter and then the applied parts menu have been accessed. At least one group has already been created.
	Configure sequence parameters (see page 83)
	Set classification parameters
	Assess visual inspection or function test with <b>OK</b> or <b>not OK</b> (toggle key)
	Enter a comment, e.g. for the visual inspection or function test
	Continue test, next test step in the test sequence
	Stop <b>continuous measurement</b> , next test in test sequence
	Accept changed parameter, return to memory view
	Stop test sequence
	– Repeat inspection (if it has been failed). – Repeat test step
	– Skip inspection test step – Skip individual tests within the test sequence This option can be enabled for the user in SETUP under "Auto Measurements".
	Start evaluation – record measured value. Each time this softkey is pressed, an additional measured value is saved and the number is increased by one.
	Start evaluation sequence during a <b>continuous measurement</b> . The number blinks.
	Record measured value during the evaluation sequence of a <b>continuous measurement</b> .

Sym- bol	Softkey Variants, Test Sequence
	Repeat measured value recording
	Delete measured value
	Display measured values
	Display details from the results list
	Hide details from the results list
	The ID number to which the measurement(s) will be stored can be entered here.
	Valid measured values have been obtained for a test sequence. This measurement can be saved.
	Save measurement data as (with display of directory path / ID or new entry of an ID other than the preselected one)
	Transmit measurement data to a PC, e.g. in order to save them to <b>IZYTRONIQ</b> report generating software (push-print function) – refer to <b>IZYTRONIQ</b> online help for a description
	Read-out of a complete test report at the end of a test sequence
	Read-out of a summarized test report at the end of a test sequence
	Read-out of all failed test steps instead of a test report at the end of the test sequence

## 10.4 Selecting and Configuring a Test Sequence

### Sample: Initial Page of a Test Sequence – Tree View Standard / Test Sequence

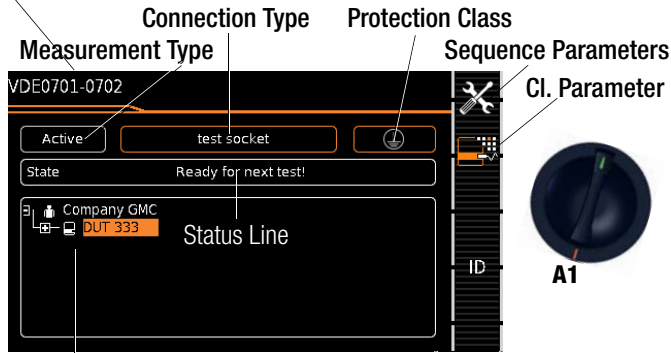

Tree View \*

### Sample: Initial Page of a Test Sequence – Detail View and Applied Standard / Test Sequence

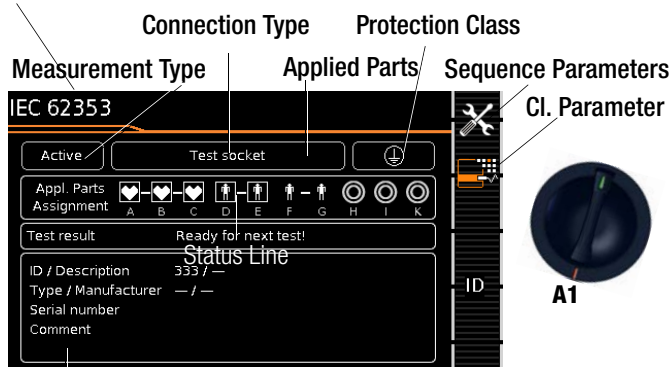

Detail View \*

#### Part

\* SETUP switch position:  
Setup Menu 1/3 > Auto Measurements > 2/2 > Initial Window Style:  
**Tree** or **Detail View**

#### Test instruments with feature E01 (touchscreen)

The display can be switched back and forth between the “tree view” and the “detail view” (see above) via “Touch Click”, i.e. by briefly tapping within the bottom frame.

#### Classification Parameter – Auto-Detection

If the settings for certain classification parameters are automatically detected by the test instrument, this is indicated in each case by an orange frame. Descriptions of these parameters are listed in the following tables relative to the respective switch positions.



##### Automatic Detection Active for Protection Class

When connecting or disconnecting a DUT, the protection class can be changed without prior authorization.



##### Automatic Detection Inactive for Protection Class

The test instrument retains the selected protection class setting when a DUT is connected or disconnected.

## Conveniently Changing Classification Parameters (feature E01, “touchscreen”)

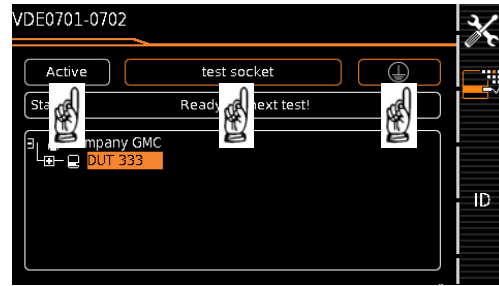

- The corresponding selection menu appears after touch clicking (briefly tapping) the respective classification parameters window.
- The display is automatically returned to the start menu after selecting the desired parameter.

### Classification Parameter – VDE 0701-0702



Parameter	Setting Options / Meaning
<b>1/2</b>	
<b>Standard</b>	<b>VDE 0701-0702</b> VDE 0701-0702-EDV, see following table IEC 60601, 2 <sup>nd</sup> edition, see table below EC 60601, 3 <sup>rd</sup> edition, see table below IEC 62353, see table below VDE 0701-0702-VLTG, see table below VDE 0701-0702-PRCD, see table below IEC 60974-4, see table below
<b>Protection class</b> <sup>1, 2</sup>	PCI, PCII, PCI+II, PCI+III, PCII+III, PCI+II+III
<b>Connection type</b> <sup>1, 2</sup>	Test socket Permanent connection Adapter: AT16/32-DI adapter Adapter: VL2E Adapter: AT3-Adapter (feature I01) Permanent connection: P1+P2 (only with feature H01)
<b>2/2</b>	
<b>Measurement type (MT)</b> <sup>1</sup>	Passive Active
<b>Auto-detection</b>	Connection & PC & MT Connection & PC Connection & MT Connection only PC & measurement type Protection class only (PC) Measurement type only (MT) <b>Disabled: No auto-detection:</b> All classification parameters such as connection, protection class and measurement type must be entered manually.

<sup>1</sup> These parameters must be entered manually if they're not automatically detected, or if they're detected incorrectly.

<sup>2</sup> The limit value for protective conductor resistance is determined on the basis of length and cross-section. Data remain in memory until a new entry is made.





Parameter	Setting Options / Meaning
<b>1/2</b>	
<b>Standard</b>	VDE 0701-0702, see previous table <b>VDE 0701-0702-EDV</b> IEC 60601, 2 <sup>nd</sup> edition, see following table EC 60601, 3 <sup>rd</sup> edition, see table below EC 60601, 3 <sup>rd</sup> edition GPA, see table below IEC 62353, see table below VDE 0701-0702-VLTG, see table below VDE 0701-0702-PRCD, see table below IEC 60974-4, see table below
<b>Protection class</b> <sup>1, 2</sup>	PCI, PCII, PCI+II, PCI+III, PCII+III, PCI+II+III
<b>Connection type</b> <sup>1, 2</sup>	Test socket Permanent connection Adapter: AT16/32 Adapter: AT3-Adapter (feature I01)
<b>2/2</b>	
<b>Measurement type (MT)</b> <sup>1</sup>	Active
<b>Auto-detection</b>	Connection & PC & MT Connection & PC Connection & MT Connection only PC & measurement type Protection class only (PC) Measurement type only (MT) <b>Disabled: No auto-detection:</b> All classification parameters such as connection, protection class and measurement type must be entered manually.

<sup>1</sup> These parameters must be entered manually if they're not automatically detected, or if they're detected incorrectly.

<sup>2</sup> The limit value for protective conductor resistance is determined on the basis of length and cross-section. Data remain in memory until a new entry is made.



Parameter	Setting Options / Meaning
<b>1/2</b>	
<b>Standard</b>	VDE 0701-0702, see table below VDE 0701-0702-EDV, see previous table <b>IEC 60601, 2<sup>nd</sup> edition<sup>2</sup></b> EC 60601, 3 <sup>rd</sup> edition, see following table EC 60601, 3 <sup>rd</sup> edition GPA, see table below IEC 62353, see table below VDE 0701-0702-VLTG, see table below VDE 0701-0702-PRCD, see table below IEC 60974-4, see table below
<b>Protection class</b> <sup>1</sup>	PCI, PCII or PCI+II
<b>Connection type</b> <sup>1</sup>	Test socket Permanent connection Adapter: AT16/32-DI adap. Adapter: AT3-Adapter Permanent connection: P1+P2 (only with feature H01)
<b>2/2</b>	
<b>Measurement type (MT)</b> <sup>1</sup>	Active
<b>Applied parts</b>	Applied parts: none, B, BF, CF or combinations <b>Type B (body):</b> Devices of this type are suitable for both internal and external patient applications, except for use in direct proximity to the heart. The following protection classes are permissible: I, II, III or devices with internal electrical power supply. <b>Type BF (body float):</b> Same as type B, but with type F insulated applied parts. <b>Type CF (cardiac float)</b> Devices of this type are suitable for use directly at the heart. The applied part may not be grounded. The following protection classes are permissible: I, II or devices with internal electrical power supply. See page 81 concerning selection of applied parts for the test sequence.
<b>Auto-detection</b>	Connection & PC & MT Connection & PC Connection & MT Connection only PC & measurement type Protection class only (PC) Measurement type only (MT) <b>Disabled: No auto-detection:</b> All classification parameters such as connection, protection class and measurement type must be entered manually.

<sup>1</sup> These parameters must be entered manually if they're not automatically detected, or if they're detected incorrectly.

<sup>2</sup> Measurement in accordance with limit values specified in the 2<sup>nd</sup> edition. Measurement of individual patient leakage current (configure APP grouping accordingly)





Parameter	Setting Options / Meaning
<b>1/2</b>	
<b>Standard</b>	VDE 0701-0702, see table below VDE 0701-0702-EDV, see table above IEC 60601, 2 <sup>nd</sup> edition, see previous table <b>EC 60601, 3<sup>rd</sup> edition</b> <sup>2</sup> EC 60601, 3 <sup>rd</sup> edition GPA, see following table IEC 62353, see table below VDE 0701-0702-VLTG, see table below VDE 0701-0702-PRCD, see table below IEC 60974-4, see table below
<b>Protection class</b> <sup>1</sup>	PCI, PCII or PCI+II
<b>Connection type</b> <sup>1</sup>	Test socket Permanent connection Adapter: AT16/32-DI adap. Adapter: AT3-Adapter Permanent connection: P1+P2 (only with feature H01)
<b>2/2</b>	
<b>Measurement type (MT)</b> <sup>1</sup>	Active
<b>Applied parts</b>	Applied parts: none, B, BF, CF or combinations <b>Type B (body):</b> Devices of this type are suitable for both internal and external patient applications, except for use in direct proximity to the heart. The following protection classes are permissible: I, II, III or devices with internal electrical power supply. <b>Type BF (body float):</b> Same as type B, but with type F insulated applied parts. <b>Type CF (cardiac float)</b> Devices of this type are suitable for use directly at the heart. The applied part may not be grounded. The following protection classes are permissible: I, II or devices with internal electrical power supply. See page 81 concerning selection of applied parts for the test sequence.
<b>Auto-detection</b>	Connection & PC & MT Connection & PC Connection & MT Connection only PC & measurement type Protection class only (PC) Measurement type only (MT) <b>Disabled: No auto-detection:</b> All classification parameters such as connection, protection class and measurement type must be entered manually.

<sup>1</sup> These parameters must be entered manually if they're not automatically detected, or if they're detected incorrectly.

<sup>2</sup> Measurement in accordance with limit values specified in the 3<sup>rd</sup> edition. Measurement of individual patient leakage current (configure APP grouping accordingly)



Parameter	Setting Options / Meaning
<b>1/2</b>	
<b>Standard</b>	VDE 0701-0702, see table below VDE 0701-0702-EDV, see table above IEC 60601, 2 <sup>nd</sup> edition, see table above EC 60601, 3 <sup>rd</sup> edition, see previous table <b>EC 60601, 3<sup>rd</sup> edition GPA</b> <sup>2</sup> IEC 62353, see following table VDE 0701-0702-VLTG, see table below VDE 0701-0702-PRCD, see table below IEC 60974-4, see table below
<b>Protection class</b> <sup>1</sup>	PCI, PCII or PCI+II
<b>Connection type</b> <sup>1</sup>	Test socket Permanent connection Adapter: AT16/32-DI adap. Adapter: AT3-Adapter Permanent connection: P1+P2 (only with feature H01)
<b>2/2</b>	
<b>Measurement type (MT)</b> <sup>1</sup>	Active
<b>Applied parts</b>	Applied parts: none, B, BF, CF or combinations <b>Type B (body):</b> Devices of this type are suitable for both internal and external patient applications, except for use in direct proximity to the heart. The following protection classes are permissible: I, II, III or devices with internal electrical power supply. <b>Type BF (body float):</b> Same as type B, but with type F insulated applied parts <b>Type CF (cardiac float)</b> Devices of this type are suitable for use directly at the heart. The applied part may not be grounded. The following protection classes are permissible: I, II or devices with internal electrical power supply. See page 81 concerning selection of applied parts for the test sequence.
<b>Auto-detection</b>	Connection & PC & MT Connection & PC Connection & MT Connection only PC & measurement type Protection class only (PC) Measurement type only (MT) <b>Disabled: No auto-detection:</b> All classification parameters such as connection, protection class and measurement type must be entered manually.

<sup>1</sup> These parameters must be entered manually if they're not automatically detected, or if they're detected incorrectly.





<sup>2</sup> Measurement in accordance with limit values specified in the 3<sup>rd</sup> edition. Measurement of overall patient leakage current (configure APP grouping accordingly)

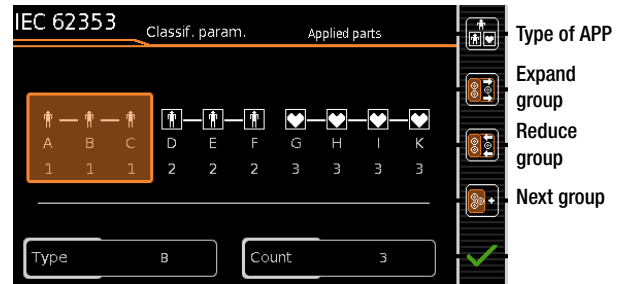
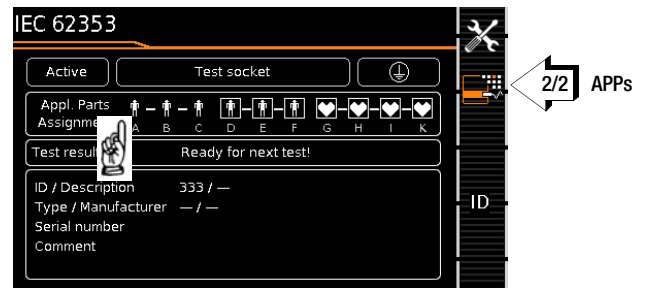

Parameter	Setting Options / Meaning
<b>1/2</b>	
<b>Standard</b>	VDE 0701-0702, see table below VDE 0701-0702-EDV, see table above IEC 60601, 2 <sup>nd</sup> edition, see table above EC 60601, 3 <sup>rd</sup> edition, see table above EC 60601, 3 <sup>rd</sup> edition GPA, see previous table <b>IEC 62353</b> VDE 0701-0702-VLTG, see following table VDE 0701-0702-PRCD, see table below IEC 60974-4, see table below
<b>Protection class</b> <sup>1</sup>	PCI, PCII or PCI+II
<b>Connection type</b> <sup>1</sup>	Test socket Permanent connection Adapter: AT16/32-DI adap. Adapter: AT3-Adapter Permanent connection: P1+P2 (only with feature H01)
<b>2/2</b>	
<b>Measurement type (MT)</b> <sup>1</sup>	Passive Active
<b>Applied parts</b>	Applied parts: none, B, BF, CF or combinations <b>Type B (body):</b> Devices of this type are suitable for both internal and external patient applications, except for use in direct proximity to the heart. The following protection classes are permissible: I, II, III or devices with internal electrical power supply. <b>Type BF (body float):</b> Same as type B, but with type F insulated applied parts <b>Type CF (cardiac float)</b> Devices of this type are suitable for use directly at the heart. The applied part may not be grounded. The following protection classes are permissible: I, II or devices with internal electrical power supply. See page 81 concerning selection of applied parts for the test sequence.
<b>Auto-detection</b>	Connection & PC & MT Connection & PC Connection & MT Connection only PC & measurement type Protection class only (PC) Measurement type only (MT) <b>Disabled: No auto-detection:</b> All classification parameters such as connection, protection class and measurement type must be entered manually.

<sup>1</sup> These parameters must be entered manually if they're not automatically detected, or if they're detected incorrectly.



- Press the “**Classification Parameter**” key. 
- Go to page 2/2.
- Press the “**Applied Parts**” key. The screen shown above appears.
- **Touch click operation:** Alternatively, this submenu can be accessed by touching the “APP Allocation” field.
- Select the desired applied part sockets with the “**Expand Group**” key. A red frame identifies the currently selected sockets, always beginning with socket A. A socket is added each time the key is pressed. The current number of selected sockets appears in the field at the bottom right. 
- The number of selected sockets can be reduced by pressing the “**Reduce Group**” key. 
- After the sockets have been selected, assign the respective type using the “**APP Type**” key. The corresponding icons are allocated to the selected sockets and the type appears in the field at the bottom left. 
- After selecting the applied parts and assigning a type, further groups can be created by pressing the “**Next Group**” key. An already created group can be edited after selecting it with the help of the input frame. 

**Note**  
 creation of additional groups with the help of the key is only possible if a type has been assigned to an already selected group.



Parameter	Setting Options / Meaning
<b>1/2</b>	
<b>Standard</b>	VDE 0701-0702, see table below VDE 0701-0702-EDV, see table above IEC 60601, 2 <sup>nd</sup> edition, see table above EC 60601, 3 <sup>rd</sup> edition, see table above EC 60601, 3 <sup>rd</sup> edition GPA, see table above IEC 62353, see previous table <b>VDE 0701-0702-VLTG</b> VDE 0701-0702-PRCD, see following table IEC 60974-4, see table below
<b>Protection class</b> <sup>1, 2</sup>	PCI
<b>Connection type</b> <sup>1, 2</sup>	Test socket Adapter: AT3-III E Adapter: EL1 adapter Adapter: VL2E adapter
<b>2/2</b>	
<b>Measurement type (MT)</b> <sup>1</sup>	VLTG <sup>2</sup>
<b>Auto-detection</b>	Connection & PC & MT Connection & PC Connection & MT Connection only PC & measurement type Protection class only (PC) Measurement type only (MT) <b>Disabled: No auto-detection:</b> All classification parameters such as connection, protection class and measurement type must be entered manually.

<sup>1</sup> These parameters must be entered manually if they're not automatically detected, or if they're detected incorrectly.

<sup>2</sup> The limit value for protective conductor resistance is determined on the basis of length and cross-section (length only in the case of EL1). Data remain in memory until a new entry is made.



Parameter	Setting Options / Meaning
<b>1/2</b>	
<b>Standard</b>	VDE 0701-0702, see table below VDE 0701-0702-EDV, see table above IEC 60601, 2 <sup>nd</sup> edition, see table above EC 60601, 3 <sup>rd</sup> edition, see table above EC 60601, 3 <sup>rd</sup> edition GPA, see table above IEC 62353, see table above VDE 0701-0702-VLTG, see previous table <b>VDE 0701-0702-PRCD</b> <sup>2</sup> IEC 60974-4, see following table
<b>Protection class</b> <sup>1, 2</sup>	PCI, PCI+II
<b>Connection type</b> <sup>1, 2</sup>	Test socket
<b>2/2</b>	
<b>Measurement type (MT)</b> <sup>1</sup>	PRCD <sup>3</sup>
<b>PRCD type</b> <sup>3</sup>	PRCD (standard) PRCD (SPE) PRCD-S (SPE) PRCD-K (SPE)
<b>Auto-detection</b>	Connection & PC & MT Connection & PC Connection & MT Connection only PC & measurement type Protection class only (PC) Measurement type only (MT) <b>Disabled: No auto-detection:</b> All classification parameters such as connection, protection class and measurement type must be entered manually.

<sup>1</sup> These parameters must be entered manually if they're not automatically detected, or if they're detected incorrectly.

<sup>2</sup> The limit value for protective conductor resistance is determined on the basis of length and cross-section. Data remain in memory until a new entry is made.

### <sup>3</sup> New classification parameters “PRCD type”

(only displayed if “Standard  
VDE 0701-0702-PRCD” parameter is selected):

- **PRCD (standard):**  
For the testing of simple circuit breaker safety adapters in which the protective conductor is permanently connected.
- **PRCD (SPE):**  
(SPE = switched protective earth) for testing PRCDs in which the protective conductor is only connected in switched-on condition.
- **PRCD-S (SPE):**  
For testing type PRCD-S circuit breaker safety adapters.
- **PRCD-K (SPE):**  
For testing type PRCD-K circuit breaker safety adapters.



#### Note

The standard or standard variant associated with the respective selector switch position corresponds to the default setting.  
Ax means that the standard variant, VDE 0701-0702-PRCD, can be selected in each of the preset switch positions.



#### Note

For more information on testing single-phase and 3-phase type S and K PRCDs by simulating faults see “PROFITEST PRCD test adapter” on our website.



#### Note

Testing of PRCDs (test sequences and time to trip) is only possible for DUTs with a nominal voltage of 230 V.



Parameter	Setting Options / Meaning
<b>1/2</b>	
<b>Standard</b>	VDE 0701-0702, see table below VDE 0701-0702-EDV, see table above IEC 60601, 2 <sup>nd</sup> edition, see table above EC 60601, 3 <sup>rd</sup> edition, see table above EC 60601, 3 <sup>rd</sup> edition GPA, see table above IEC 62353, see table above VDE 0701-0702-VLTG, see table above VDE 0701-0702-PRCD, see previous table <b>IEC 60974-4</b>
<b>Protection class</b> <sup>1</sup>	PCI, PCII or PCI+II
<b>Connection type</b> <sup>1</sup>	Test socket Permanent connection Adapter: AT16/32-DI adap. Adapter: AT3-Adapter
<b>2/2</b>	
<b>Measurement type (MT)</b> <sup>1</sup>	Active
<b>Voltage, rating plate</b>	Voltage from rating plate, U(R) RMS (RMS limit value, variably adjustable) or open-circuit voltage U0 DC (limit value = 113 V DC)
<b>Auto-detection</b>	Connection & PC & MT Connection & PC Connection & MT Connection only PC & measurement type Protection class only (PC) Measurement type only (MT) <b>Disabled: No auto-detection:</b> All classification parameters such as connection, protection class and measurement type must be entered manually.

<sup>1</sup> These parameters must be entered manually if they're not automatically detected, or if they're detected incorrectly.

## Sequence Parameters



The default test sequences can be adapted to your application or test standard via the sequence parameters. The entered sequence parameter settings are only valid for the currently selected switch position (A1 to A9) and are retained until they are changed. Not all of the parameters are relevant, depending on the selected DUT classification (protection class etc.).

Sequence Parameters	Meaning
<b>Visual inspection (1)</b>	Visual inspection (standard): on: activate off: deactivate
<b>Visual inspection 2 (IEC 60974-4)</b>	Visual inspection, function test, welding units on: activate off: deactivate
<b>Function test</b>	Function test: on: activate off: deactivate
<b>Protective conductor resistance test</b>	
<b>RPE</b>	Protective conductor resistance test: on: activate off: deactivate
<b>RPE IP</b>	Protective conductor resistance at test socket: Select test current IP: ±200 mA= / 200 mA~ / Feature G01: 10 A~ / feature G02: 25 A~
<b>RPE IP permanent connection</b>	Protective conductor resistance with permanent connection: Select test current IP: ±200 mA= / 200 mA~ / Feature G01: 10 A~ / feature G02: 25 A~
<b>RPE as</b>	Protective conductor resistance test: Execute as individual or multiple measurement. Multiple measurement: Repeat testing of various conductive parts as often as desired, in the event that it's not clear as to whether or not all accessible, conductive parts are connected to each other or to the protective conductor.
<b>RPE measurement duration</b>	Protective conductor resistance test: A measurement duration within a range of 0 to 60 seconds can be entered here.
<b>Insulation resistance test</b>	
<b>RINS PC I</b>	Insulation resistance tests for PCI: on: activate off: deactivate
<b>RINS PC II</b>	Insulation resistance tests for PCII: on: activate off: deactivate
<b>RINS PC I and II (VDE 0701-0702) (IEC 60974-4)</b>	Insulation resistance tests for PCI and II: on: activate off: deactivate
<b>RINS at AP</b>	Insulation resistance tests at applied parts: on: activate off: deactivate
<b>Measurement duration RINS probe</b>	Insulation resistance test via probe: A measurement duration within a range of 0 to 60 seconds can be entered here. Default setting: 3 s
<b>Measurement duration RINS AP</b>	Insulation resistance tests at applied parts: A measurement duration within a range of 0 to 60 seconds can be entered here. Default setting: 3 s
<b>RINS pri./sec. (VDE 0701-0702) (IEC 60974-4)</b>	Insulation resistance test between the primary and secondary sides of PCIII DUTs on: activate off: deactivate
<b>RINS PC II as (VDE 0701-0702) (IEC 60974-4)</b>	Insulation resistance test: Execute as individual or multiple measurement. Multiple measurement: Insulation resistance is measured between short-circuited mains terminals (L-N) and accessible, conductive parts which can be contacted with test probe P1 and are not connected to the housing, repeat as often as desired.
<b>Measurement duration RINS PC II</b>	Insulation resistance test: A measurement duration within a range of 0 to 60 seconds can be entered here. Default setting: 3 s
<b>RINS sec./PE (VDE 0701-0702) (IEC 60974-4)</b>	Insulation resistance test between the secondary side and PE of PCIII DUTs: on: activate off: deactivate

Sequence Parameters	Meaning
<b>Leakage current tests</b>	
<b>Reverse polarity</b>	Leakage current tests: On: Measurements are conducted with both polarities. Off: Measurement is only conducted with one/momentary polarity.
<b>IPE</b> (VDE 0701-0702) (IEC 60974-4)	Protective conductor current: on: activate off: deactivate
<b>IPE measurement type (active)</b> (VDE 0701-0702)	Protective conductor current test (mains to test socket): Measuring method: Direct or differential
<b>IPE measurement duration</b> (VDE 0701-0702) (IEC 60974-4)	Protective conductor current test: A measurement duration within a range of 0 to 60 seconds can be entered here. Default setting: 3 s
<b>IE</b> (IEC 62353)	Device leakage current test: on: activate off: deactivate
<b>IE measurement type (active)</b> (IEC 62353)	Device leakage current test (mains to test socket): Measuring method: Direct or differential
<b>IE measurement duration</b> (IEC 62353)	Device leakage current test: A measurement duration within a range of 0 to 60 seconds can be entered here. Default setting: 3 s
<b>IT measurement type (active)</b> (VDE 0701-0702)	Touch current test (mains to test socket): Measuring method: Direct P1 or differential P1 The "Differential P1" method is only advisable in this case if the device under test has ground connections which cannot be disconnected for testing.
<b>IT</b> (IEC 62353) (IEC 60601)	Touch current test on: activate off: deactivate
<b>IT as</b> (IEC 62353)	Touch current test: Execute as individual or multiple measurement. Multiple measurement: Various accessible, conductive parts are contacted with test probe P1 in order to measure current flowing to the protective conductor via the probe – repeat as often as desired.
<b>IT measurement duration</b> (IEC 62353)	Touch current test: A measurement duration within a range of 0 to 60 seconds can be entered here. Default setting: 3 s
<b>IT welding circuit</b> (IEC 60974-4)	Touch current test at welding circuit: on: activate off: deactivate
<b>IT PC II as</b> (IEC 60974-4)	Touch current test at welding circuit: Execute as individual or multiple measurement.
<b>IT PC II measurement duration</b> (IEC 60974-4)	Touch current test at welding circuit: A measurement duration within a range of 0 to 60 seconds can be entered here. Default setting: 3 s
<b>IP AC</b> (IEC 60601)	Patient leakage current AC: on: activate off: deactivate
<b>IP DC</b> (IEC 60601)	Patient leakage current DC: on: activate off: deactivate
<b>IP measurement duration</b> (IEC 60601)	Patient leakage current: A measurement duration within a range of 0 to 60 seconds can be entered here. Default setting: 3 s
<b>Test conditions / fault conditions</b>	
<b>APP &gt; PE</b> (IEC 60601)	Applied part to ground: On: Test steps with this test condition are executed. Off: Test steps with this test condition are skipped.
<b>Housing &gt; PE</b> (IEC 60601)	Housing to ground: On: Test steps with this test condition are executed. Off: Test steps with this test condition are skipped.
<b>APP/Housing &gt; APP</b> (IEC 60601)	Applied part / housing to applied part: On: Test steps with this test condition are executed. Off: Test steps with this test condition are skipped.
<b>SFC voltage at APPs</b> (IEC 60601)	Single fault: Voltage at applied part On: Test steps with this single fault are executed. Off: Test steps with this single fault are skipped
<b>SFC PE interrupted</b> (IEC 60601)	Single fault: PE interrupted On: Test steps with this single fault are executed. Off: Test steps with this single fault are skipped
<b>IA</b> (IEC 62353)	Leakage current test at applied part: on: activate off: deactivate
<b>Measurement duration IA AP</b> (IEC 62353)	Leakage current test at applied part: A measurement duration within a range of 0 to 60 seconds can be entered here. Default setting: 3 s

Sequence Parameters	Meaning
<b>Connection and fuse tests</b>	
<b>Short-circuit test L-N</b>	Short-circuit test between L and N <sup>1</sup> on: activate off: deactivate
<b>Short-circuit test LN-PE</b>	Short-circuit test between LN and PE1 <sup>1</sup> on: activate off: deactivate
<b>Display test instructions</b>	Test instructions which are not necessarily required for experienced inspectors. on: activate off: deactivate
<b>Fuse test</b>	Testing the fuses: Mains fuses, test probe fuse P1, applied part fuses
<b>Other parameters</b>	
<b>Open-circuit voltage</b> (IEC 60974-4)	Open-circuit voltage at welding unit on: activate off: deactivate
<b>Supply voltage PC III</b> (VDE 0701-0702)	Supply voltage measurement (with PCIII DUTs, for measurement type "Active" only) on: activate off: deactivate
<b>Testing of extension cords – additional parameters (VDE 0701-0702-VLTG)</b>	
<b>Continuity test</b>	Testing of conductors (L, N, PE) for continuity with the help of the EL1/VL2E/AT3-IIIIE adapter on: activate off: deactivate
<b>Testing of PRCDs – additional parameters (VDE 0701-0702-PRCD)</b>	
<b>RPE IP (standard PRCD)</b>	Protective conductor resistance test with standard PRCDs: Select test current IP: ±200 mA= / 200 mA~ / Feature G01: 10 A~ / feature G02: 25 A~
<b>Varistor test PRCD-K</b>	Varistor test at type K PRCDs: on: activate off: deactivate
<b>Sensor surface test</b>	Testing of the sensor surface of the PRCD: on: activate off: deactivate
<b>Manual tripping test</b>	Manual tripping of the PRCD: on: activate off: deactivate
<b>Time to trip</b>	Tripping of the PRCD after xx seconds: on: activate off: deactivate

### ❑ Suppressing Test Steps

Depending on the selected test standard, some of the following test steps can be suppressed:

Parameter	Suppressible test steps
Visual inspection (1)	Visual inspection, standard
Visual inspection 2	Visual inspection, function test, welding units
Function test	Function test
RPE	Protective conductor resistance test
RINS PCI+II	Insulation resistance tests for PCI and PCII
RINS pri./sec.	Insulation resistance test between the primary and secondary sides of PCIII DUTs
RINS sec./PE	Insulation resistance test between the secondary side and PE of PCIII DUTs
Polarity reversal	All leakage current measurements with reversed polarity
IPE measurement type (active)	Protective conductor current test
IT	Touch current test
IT welding circuit	Touch current test at welding circuit
Display test instructions	Test instructions which are not necessarily required for experienced inspectors.
Short-circuit test L-N	Short-circuit test between L and N <sup>1</sup>
Short-circuit test LN-PE	Short-circuit test between LN and PE1 <sup>1</sup>
Open-circuit voltage (IEC 60974-4)	Open-circuit voltage at welding unit
Continuity test (VLTG test only)	Continuity test with EL1/VL2E/AT3-III E adapter
PCIII supply voltage	Supply voltage measurement (with PCIII DUTs, for measurement type "Active" only)

<sup>1</sup> Before switching line voltage to the device under test, a short-circuit test is conducted regardless of this setting.

### ❑ Setting Measuring Parameters for Individual Test Steps

Depending on the selected test standard, some of the following test steps can be selected:

Parameter	Meaning
RPE IP	Select test current for protective conductor resistance test: 200 mA AC, ±200 mA DC, 10 A AC <sup>1</sup> or 25 A AC <sup>2</sup>
IPE measurement type (active)	Set measurement type of the protective conductor current measurement for the active device test (differential/direct)
IE measurement type (active) (IEC 62353)	Set measurement type of the device leakage current measurement for the active device test (differential/direct)

<sup>1</sup> Feature G01

<sup>2</sup> Feature G02

### ❑ Selecting Between Single and Multiple Measurement for Individual Test Steps

Parameter	Meaning
RPE as	Switch the "protective conductor resistance" test step back and forth between multiple and single measurement

Parameter	Meaning
RINS PC II as	Switch back and forth between multiple and single measurement for the insulation resistance measurement at PC II parts (measurements at applied parts and welding outputs are not affected)
IT as	Switch back and forth between multiple and individual measurement for the touch current measurement
IT PC II as	(IEC 60974 only) Switch back and forth between multiple and individual measurement for touch current measurement at PC II parts

### ❑ Setting Measurement Duration for Individual Test Steps

Testing time for the respective measurement can be influenced with these parameters. If a test step for a single measurement is involved, the entire test step has a duration of the time entered in seconds. If a test step for a multiple measurement is involved, the measurement duration for each measuring point is influenced.

If 0 seconds is selected, continuous measurement is conducted which can only be ended by pressing a key.

Parameter	Meaning
RPE measurement duration <sup>1</sup>	Set testing time for the protective conductor resistance measurement (0 to 60 seconds)
IPE measurement duration	Set testing time for the protective conductor current measurement (0 to 60 seconds)
IE measurement duration	Set testing time for the device leakage current measurement (0 to 60 seconds)

<sup>1</sup> In the case of test sequence VDE 0701-0702-PRCD with a setting of "PRCD type: PRCD (SPE)", measurement duration **cannot** be influenced. The measurement duration which has been set here only affects the RPE measurement with PRCD types "PRCD (standard)" and "PRCD-S (SPE)".

Parameter	Meaning
IT measurement duration	Set testing time for touch current measurement (0 to 60 seconds)
IT PC II measurement duration	(for IEC 60974 only) Set testing time for touch current measurement at PC II parts (with the exception of welding outputs) (0 to 60 seconds)
RINS PC II measurement duration	Set testing time for RINS measurements at PC II parts (0 to 60 seconds)

## 10.5 Connecting the DUT

- ⇨ Connect the DUT to the test instrument in accordance with the selected test sequence.
  - Test socket
  - Permanent connection
  - Adapter

### Note concerning use of the AT3-IIIE test adapter

Please note that polarity reversal with the help of the utilized test instrument isn't active when the AT3-IIIE adapter is used for testing single-phase DUTs (socket 3 / earthing contact). In this case, all leakage current measurements must be performed manually with the plug in **both** directions.

### Switch Settings A1 ... A9



Connection depends on the type of DUT (see the respective connection type in the classification parameters tables).

### VDE 0701-0702-VLTG

For testing extension cords in accordance with standards: connection to the test socket via the following adapter:

- **EL1:** for single-phase extension cords
- **VL2E:** for single and 3-phase extension cords

## 10.6 Selecting a Test Object

- ⇨ If no DUT has been selected in the initial display, enter its ID number (for example using a barcode scanner) after selecting ID.
- ⇨ Alternatively, activate the database view with the **MEM** key. 
- ⇨ Select the DUT for the test sequence with the scroll keys. 
- ⇨ Return to the measuring view by pressing the **ESC** key. 

## 10.7 Checking Connection and Starting the Test Sequence

- ⇨ Trigger the connection test and the test sequence by pressing the **START** key. 

The following checks are run automatically before the test sequence is started:

- P1 probe test (determines whether or not test probe P1 is connected and fuse link P1 is intact)



### Attention!

If the fuse at test probe P1 is defective, all subsequent measurements using this measuring path are incorrectly evaluated as good!

- Insulation test (whether or not the DUT is set up in a well-insulated fashion)
- On test and short-circuit test (prerequisite: sequence parameter for "short-circuit test L-N" is preset to "on". In order to be able to detect a short-circuit at the DUT, testing is conducted between L and N, as well as LN and PE.



### Note

If you deselect important test steps under sequence parameters (set to off), the test sequence might not fulfill the requirements stipulated by the standard any more.

If you have set the "**Detected classification**" parameter for the respective test sequence to "Always accept" and the "**Auto-detection of**" parameter to "Connection and PC" (before triggering **Start**), the following additional checks will be run before the test sequence is started:



- Protection class detection for DUTs with protective conductor \*

- Connection test \*: Checks whether the DUT is connected to the test socket. In the case of protection class I: whether or not the two protective conductor terminals are short-circuited.



\* Applies to **M7050** with feature B00 and B09 and B49

## 10.8 Executing and Evaluating Test Steps

### Manual Evaluation of Visual Inspection

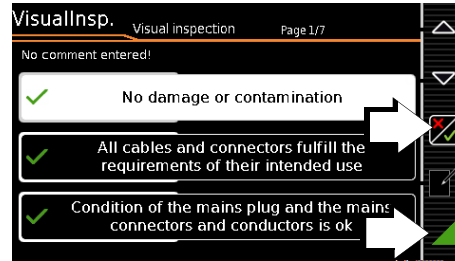
(prerequisite: "visual inspection" sequence parameter is preset to "on".)



- ⇨ Evaluate the visual inspection. 
- ⇨ If you mark even one visual inspection as not passed with the key shown at the right, the sequence is aborted and the test is evaluated as not passed.
- ⇨ Resume the test sequence. 



### Connecting Line Voltage

Connecting line voltage to the test socket at the test instrument and performance of a function test are only permissible if the DUT has already passed all **safety test steps!** Depending on the DUT's protection class, this means that visual inspection, as well as measurement of protective conductor resistance and insulation resistance, must have been passed.

Do not start measurements at your test instrument unless the test instrument and the DUT are in plain view. Do not connect line voltage to the test socket of your test instrument before the surrounding area has been secured.

### Test Steps with Manual Evaluation (e.g. R<sub>PE</sub>)



- ⇨ Observe instructions which appear at the display, e.g. prompting to contact parts with test probe P1.
- If the measured value appears green at the display, it lies within the limits specified by the standard.
- ⇨ The measured value recording symbol appears in the softkey bar. The 0 indicates that no measured values have thus far been saved to buffer memory. 
- ⇨ Each time this key is pressed, the measuring or evaluation procedure is restarted.
- ⇨ Initially the digit blinks (here a 1 without icon) until the measured value settles in. The evaluation cycle is visualized as follows: the progress bar starts at the left-hand edge of the display and moves to the right. When it reaches the rightmost position, evaluation has been completed and the symbol shown at the right appears with the current number. 
- ⇨ Depending on whether you want to delete the last value saved to the clipboard or all values, press the symbol with the wastebasket shown at the right an appropriate number of times. 



- Proceed to the next measurement by pressing the key shown at the right.



### Attention!

#### Limit Value Violation

If the measured value appears red at the display, a limit value has been violated. If you nevertheless start the evaluation procedure, an error message appears. You have the option of repeating the evaluation procedure.

If **Continue** is selected for the "Limit Violation" option in SETUP (Auto Measurements 2/3), the test instrument continues testing despite any limit value violations. In this case, the device under test is operated with line voltage despite any insulation faults or the like. Make sure that the device under test is secured, in particular against contact during the testing process.



### Test Steps with Automatic Evaluation (R<sub>INS</sub>, I<sub>PE</sub>)

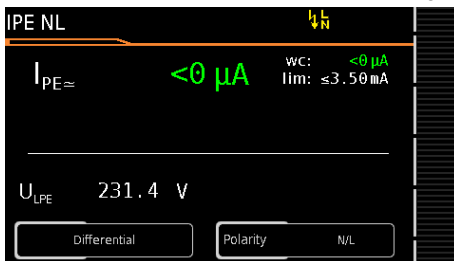

The measured value is ascertained automatically within a specified period of time. The evaluation cycle is visualized as follows: the progress bar starts at the left-hand edge of the display and moves to the right. When it reaches the rightmost position, evaluation has been completed. The test sequence is then automatically resumed.

### Manual Evaluation of the Function Test

(prerequisite: "function test" sequence parameter is preset to "on".)

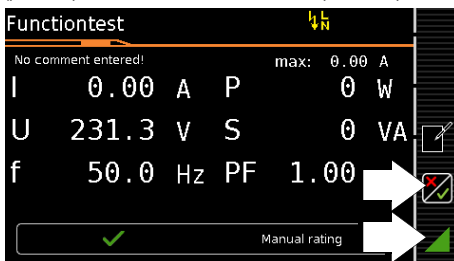

- Evaluate the function test:
- If you mark the function test as not passed with the softkey shown at the right, the sequence is aborted and the test is evaluated as not passed.
- If you evaluate the function test as passed, you can simply continue with the test sequence.



In either case you can enter a comment, which can be subsequently edited as well.

### 10.9 Setting Limit Values Manually

If "Expert" is selected instead of "Normal" in setup under "Auto Measurements" in the "Limit Value Mode" submenu, the LIMIT softkey appears next to the "measurement failed" popup. This key makes it possible to enter a user-defined limit value (as a rule a limit value specified by the manufacturer which deviates from the standard):



#### Note

Selecting "continue" or "Try Again" rules out the possibility of entering a limit value.

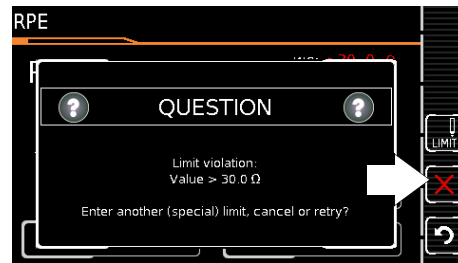

### 10.10 Ending the Test Sequence

"Sequence finished" appears at the display.

#### Initial Display (memory screen)

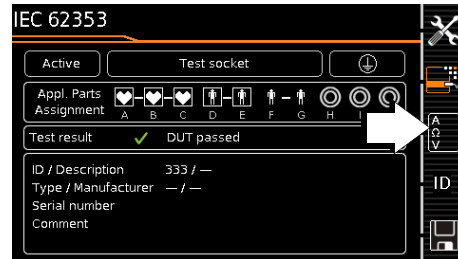

Display of the memory screen depends on the setting in the setup menu in the **SETUP** switch position:

Setup 1/3 > Auto Measurements > At End of Sequence > "Memory Screen".

If set to **Results list**, the above display is skipped and the results list shown below is displayed.

You can also access the results list by pressing the key shown at the right.



#### Results List Display

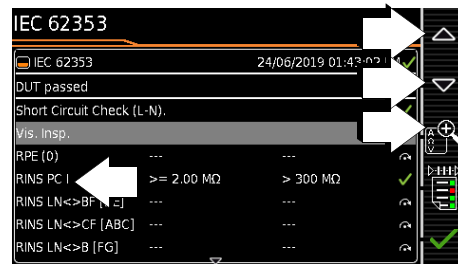

- Select the desired test step with the scroll keys.
- If you want to view details for the selected test step, press the **magnifying glass+** key.
- You can still select from amongst 3 report views (see below).





Filter Icon	Meaning of the Selectable Report View
	During report display: show complete test report
	During report display: show summarized (abridged) test report *
	During report display: show failed test steps only

\* Skipped test steps are not shown in the abridged view – only the worst measured value for each measurement type is shown.

Taking measuring error into consideration depends on the setting in the setup menu in the **SETUP** switch position: Setup 1/3 > Auto Measurements > Error Considered. > **Yes**

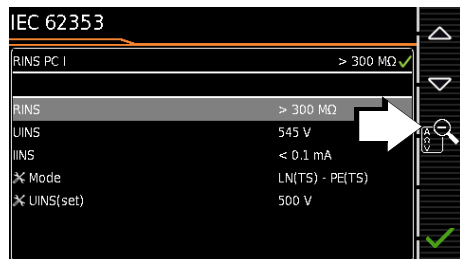
## Display of Details for Individual Test Steps



- ⇒ The display is returned to the list of test steps by pressing the **magnifying glass**- key. 
- ⇒ The memory screen is displayed again after acknowledging the list. 

### 10.11 Saving Test Results

- ⇒ Save the results of a successful test sequence by pressing the **Save** key. 

Or with feature **KD01**, “**Z853S – SECUTEST DB COMFORT**”:

- 1  Transmit measurement data to PC via USB or *Bluetooth*<sup>®</sup> (**feature M01**), e.g. for saving to **IZYTRONIQ** report generating software (push-print function) (see **IZYTRONIQ** online help for description)

Observe notes regarding storage in section 7.

## 11 Warnings, Error Messages and Notes

Error messages or notes regarding the individual tests or test sequences are displayed as popups.

Differentiation is made amongst 5 types of messages:

- Fatal error
- Error
- Warning
- Note – INFO
- Question

### Fatal Error

This message indicates an extraordinary error. Fatal errors have to be acknowledged or cleared by pressing the **OK** key, and the cause of error must be eliminated before the test or the test sequence can be resumed.



### Error

This message indicates, for example, operator errors. These errors have to be acknowledged or cleared by pressing the **OK** key, and the cause of error must be eliminated before the test or the test sequence can be resumed.

Examples:

- Object cannot be created. General database error!

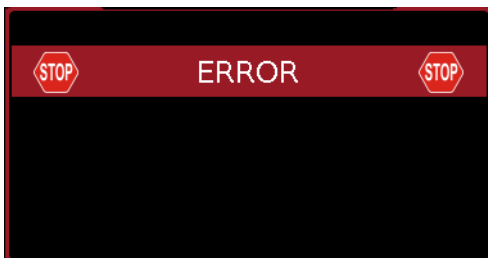

### Warning

Warnings indicate hazards which, if not avoided, may result in severe injury. **Single test:** The warning has to be acknowledged or cleared by pressing the **OK** key before the test or the test sequence can be resumed.

**Test sequence:** The test sequence can be aborted or resumed without acknowledging.

Examples:

- Caution: Line voltage will be switched to the test socket!
- Caution: Line voltage polarity will be reversed at the test socket!



### Note – INFO

A note is either information regarding the functions executed by the test instrument or instructions which may have to be acknowledged or can be skipped by pressing the **OK** key.

Examples:

- Probe test
- Set up in a well-insulated fashion?
- On test
- Short-circuit test (L-N)
- Short-circuit test (LN-PE)
- Prompt: Contact with test probe P1 ...
- Prompt: Switch the DUT on/off with its own mains switch ...
- Prompt: Start up / shut down the DUT ...





### Question



Questions must be answered by pressing **Yes** or **No** before the single test or test sequence is resumed.

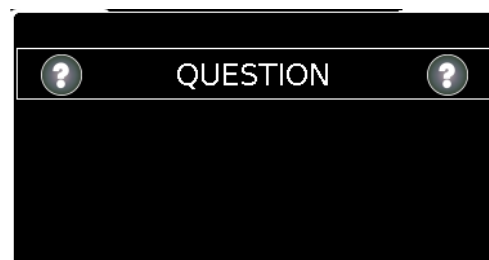

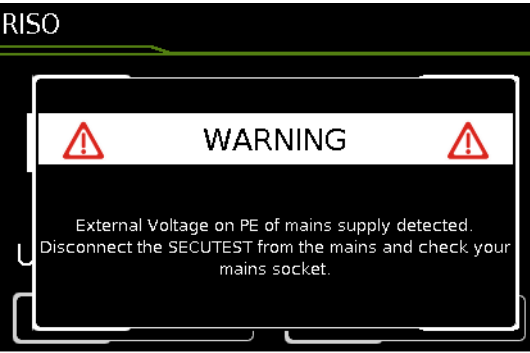
Example:

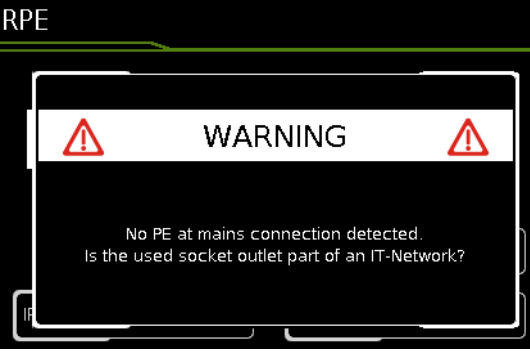
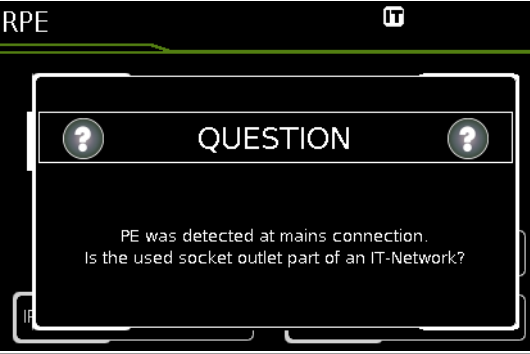
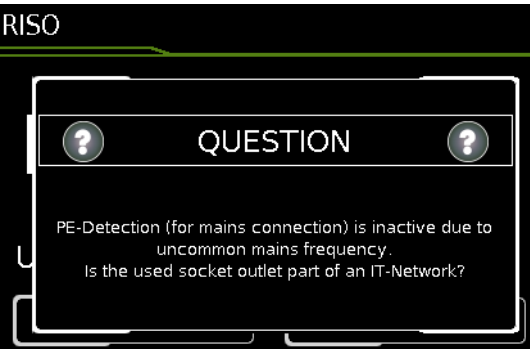
- Device not found!  
Create new object/database?

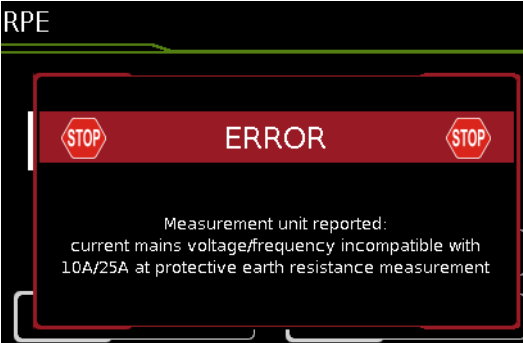
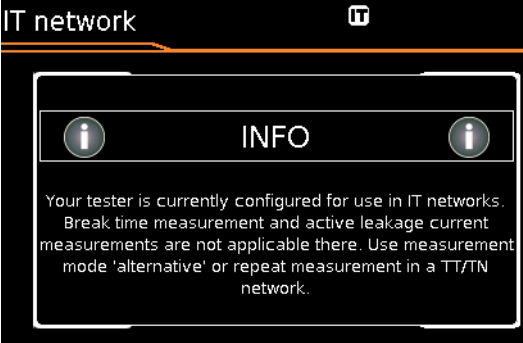

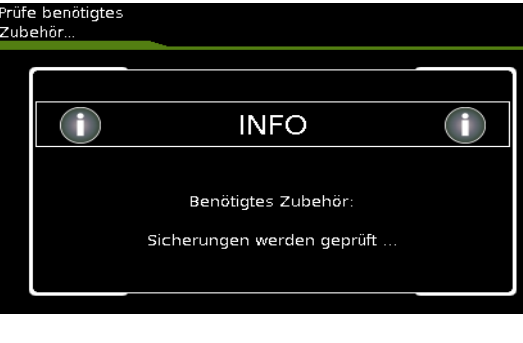
Error Messages	Possible Causes	Corrective Measures
<b>Mains Connection Errors</b>		
<p>RISO</p> 	<ul style="list-style-type: none"> <li>– Protective conductor PE at the mains outlet at which the test instrument is being operated is conducting voltage! This detection function makes use of the metalized START/STOP key on the test instrument. In order for detection to function correctly, it must be possible to establish reference to earth potential via the user's finger.</li> </ul> <p> <b>Note</b> If the user's finger is insulated from the key when it's pressed, this error message may occur although the installation is OK (see "Automatic Recognition of Mains Connection Errors" on page 13).</p>	<ul style="list-style-type: none"> <li>⇨ Please remove the test instrument's mains plug from this outlet and arrange to have the outlet/installation inspected by a qualified electrician without delay. Do not operate any other devices at this electrical outlet before this inspection has been completed.</li> <li>⇨ In order to ensure that detection functions reliably, repeat the interference voltage test and observe the following tips:             <ul style="list-style-type: none"> <li>– Unplug all USB devices from the test instrument's USB ports.</li> <li>– Remain in contact with a grounded object while pressing the START/STOP key (e.g. a heating pipe).</li> <li>– Do not contact the START/STOP key with an object or while wearing gloves.</li> </ul> </li> </ul>
<p>RPE</p> 	<p>PE connection not detected (at the outlet at which the test instrument is being operated):</p> <ul style="list-style-type: none"> <li>– If the installation is defective!</li> <li>– In the case of special types of TT systems; detection may fail in this case.</li> <li>– If the test instrument is being operated in an IT system</li> </ul>	<ul style="list-style-type: none"> <li>⇨ If the test instrument is being operated in an IT system: Acknowledge the question by pressing <b>✓</b> – the IT system option is activated in this case.</li> <li>⇨ If it's not an IT system: remove the mains plug from the outlet and inspect the installation without delay!</li> <li>⇨ If it's a TT system without neutral conductor, press <b>✗</b>; direct leakage current measurements are possible. (Please make absolutely sure that direct leakage current measurements are possible in your current mains type!)</li> </ul>
<p>RPE</p> 	<p>As opposed to the previously used mains connection, PE was detected while the IT system option was activated in setup.</p>	<ul style="list-style-type: none"> <li>⇨ Operation in an IT system: Respond to the question by pressing <b>✓</b>. The IT system option remains active as a result.</li> <li>⇨ Operation in TN or TT system: Respond to the question by pressing <b>✗</b>. The IT system option is deactivated as a result.</li> </ul>
<p>RISO</p> 	<p>Line frequency is less than 48 or greater than 62 Hz</p>	<ul style="list-style-type: none"> <li>⇨ PE detection does not function in this case: select <b>✓</b> or <b>✗</b> depending on whether or not the utilized system is an IT system.</li> </ul>

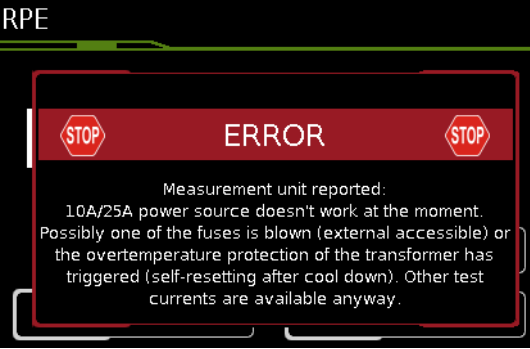
Error Messages	Possible Causes	Corrective Measures
	<ul style="list-style-type: none"> <li>– Momentary line voltage at the test instrument is outside of the permissible range (110 to 120 V or 220 to 240 V) for a 10 A/25 A <math>R_{PE}</math> measurement.</li> </ul>	<ul style="list-style-type: none"> <li>⇒ The 10 A/25 A <math>R_{PE}</math> measurement is only available when line voltage is between 220 and 240 V at 50 or 60 Hz, or between 110 and 120 V at 50 or 60 Hz.</li> <li>⇒ If you're using the test instrument in an electrical system which does not lie within one of these voltage ranges, use the 200 mA test current in order to determine protective conductor resistance.</li> </ul>
	<ul style="list-style-type: none"> <li>– IT system option (see section 4.1.1, "Measurements in IT Systems") is activated. An attempt has been made to start an active leakage current measurement or a measurement with reference to PE at the mains connection end (or a test sequence which includes such measurements).</li> </ul>	<ul style="list-style-type: none"> <li>⇒ Select measurement type "passive".</li> <li>or</li> <li>⇒ Conduct the desired tests in a TT/TN system instead of an IT system and configure the test instrument accordingly.</li> <li>or</li> <li>⇒ Deactivate leakage current measurements in the sequence parameters if possible.</li> </ul>
<b>Connection Error at the Applied Part Connections</b>		
	<ul style="list-style-type: none"> <li>– At least one of the two fuse links for applied part connections A through K is missing or defective.</li> <li>– Test results are invalid.</li> </ul>	<ul style="list-style-type: none"> <li>⇒ Stop the test.</li> <li>⇒ Disconnect the test instrument from the mains.</li> <li>⇒ Check the fuse links for the applied part connections.</li> </ul>
	<ul style="list-style-type: none"> <li>– <b>In the event that this message does not just appear briefly, but rather persists uninterruptedly:</b> At least one of the two fuse links for applied part connections A through K is missing or defective.</li> </ul>	<ul style="list-style-type: none"> <li>⇒ Stop the test.</li> <li>⇒ Disconnect the test instrument from the mains.</li> <li>⇒ Check the fuse links for the applied part connections.</li> </ul>

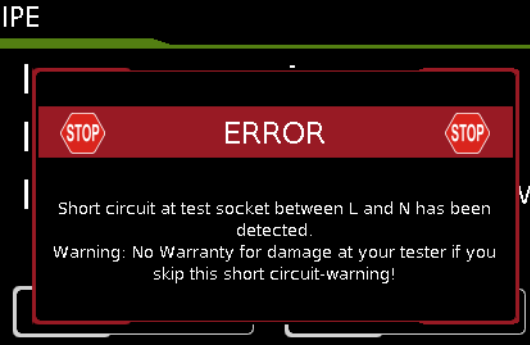
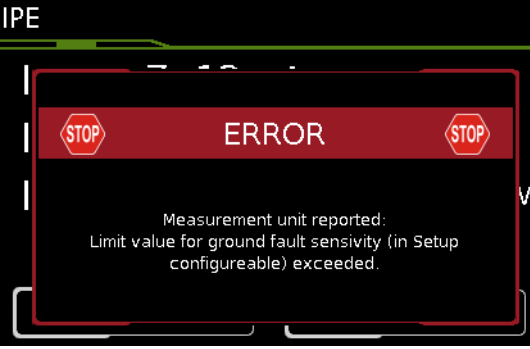
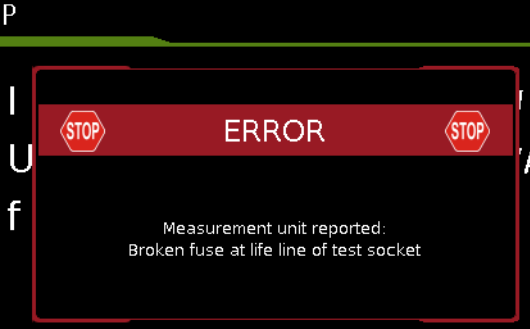
Error Messages	Possible Causes	Corrective Measures
<b>Connection Error at the Test Socket</b>		
	<ul style="list-style-type: none"> <li>– Test probe P1 isn't connected.</li> <li>or</li> <li>– The test instrument's 10 A/25 A transformer is overheated.</li> <li>or</li> <li>– One of the fuses has blown (fuse holder in close proximity to the mains input).</li> </ul>	<ul style="list-style-type: none"> <li>⇨ Repeat measurement with probe P1 connected.</li> <li>⇨ Check the fuses and replace if necessary.</li> <li>⇨ Select a different test current (e.g. 200 mA) or wait until the transformer has cooled down and then repeat the measurement.</li> </ul> <div style="border: 1px solid black; padding: 5px; margin-top: 10px;">  <p><b>Attention!</b> The 10 A/25 A measurement isn't suitable for continuous operation!</p> </div>
	<ul style="list-style-type: none"> <li>– A short-circuit has been detected at the test socket between L and N.</li> </ul>	<ul style="list-style-type: none"> <li>⇨ Determine whether or not the device under test is defective.</li> <li>⇨ In the case of DUTs which are intended for operation at an outlet that's protected with a 16 A fuse, a short-circuit may be detected under certain circumstances if, for example, they include a PTC thermistor (e.g. large floodlights). Be sure to use a 3-phase test adapter in order to test devices of this sort (e.g. the AT3-III E).</li> <li>⇨ You can skip this short-circuit message at your own risk and place the device under test into service. Any damage resulting from skipping this warning is excluded from the guarantee!</li> </ul>
	<ul style="list-style-type: none"> <li>– A device under test, whose leakage current (measured by means of the differential current method) exceeds the limit value specified in SETUP, is connected to the test instrument and has been started up.</li> </ul>	<ul style="list-style-type: none"> <li>⇨ If the device under test normally generates a leakage current of greater than 10 mA (e.g. large heaters), temporarily increase the "residual current protection" value selected in setup to 30 mA and try again.</li> <li>⇨ If values of this magnitude are not to be expected for the respective device under test, or if the "residual current protection" value has already been set to 30 mA in Setup, there may be a ground fault at the DUT.</li> </ul>
	<ul style="list-style-type: none"> <li>– The fuse for the test socket's L conductor has blown (fuse link 2).</li> </ul>	<ul style="list-style-type: none"> <li>⇨ Disconnect the test instrument from the mains and inspect the fuses next to the it's mains connection.</li> </ul>

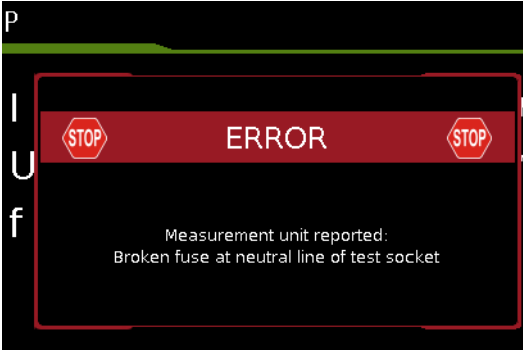
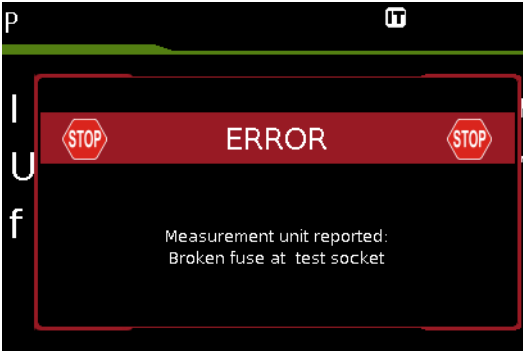
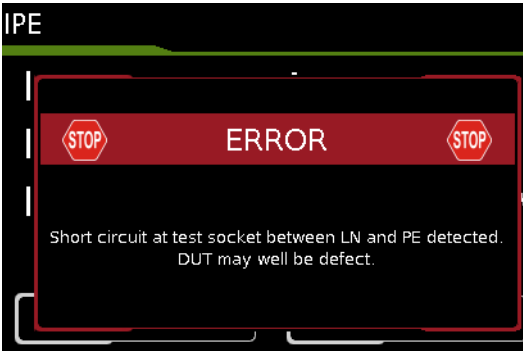
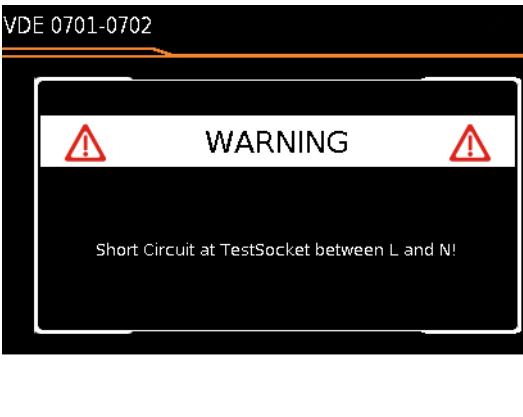
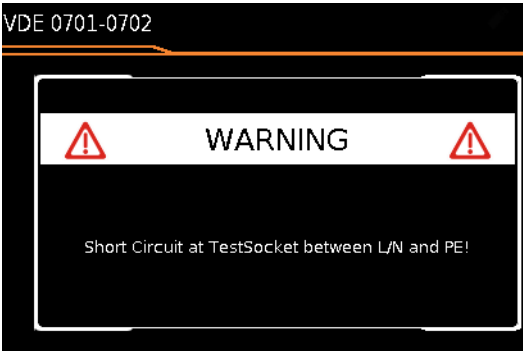
Error Messages	Possible Causes	Corrective Measures
	<ul style="list-style-type: none"> <li>- The fuse for the test socket's N conductor has blown (fuse link 1).</li> </ul>	<ul style="list-style-type: none"> <li>⇒ Disconnect the test instrument from the mains and inspect the fuses next to the it's mains connection.</li> </ul>
	<ul style="list-style-type: none"> <li>- One of the two fuses for the test socket has blown (fuse link 1 or 2).</li> </ul>	<ul style="list-style-type: none"> <li>⇒ Disconnect the test instrument from the mains and inspect the fuses next to the it's mains connection.</li> </ul>
	<ul style="list-style-type: none"> <li>- A short-circuit has been detected at the test socket between L/N and PE.</li> </ul>	<ul style="list-style-type: none"> <li>⇒ Determine whether or not the device under test is defective. Repeat the visual inspection.</li> </ul>
	<ul style="list-style-type: none"> <li>- A short-circuit has been detected at the test socket between L and N.</li> </ul>	<ul style="list-style-type: none"> <li>⇒ Determine whether or not the device under test is defective.</li> <li>⇒ In the case of DUTs which are intended for operation at an outlet that's protected with a 16 A fuse, a short-circuit may be detected under certain circumstances if, for example, they include a PTC thermistor (e.g. large floodlights). Be sure to use a 3-phase test adapter in order to test devices of this sort (e.g. the AT3-IIIIE).</li> <li>⇒ You can deactivate this short-circuit test in the sequence parameters at your own risk.</li> </ul>
	<ul style="list-style-type: none"> <li>- A short-circuit has been detected at the test socket between L/N and PE.</li> </ul>	<ul style="list-style-type: none"> <li>⇒ Determine whether or not the device under test is defective. Repeat the visual inspection.</li> </ul>



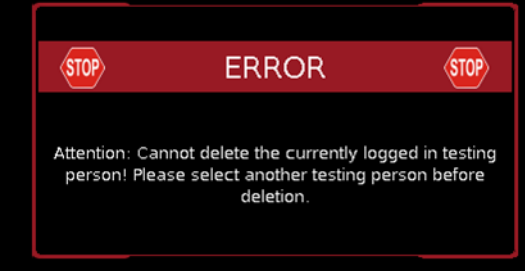
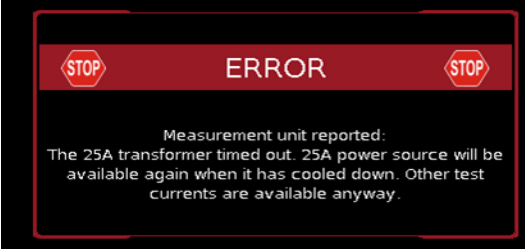
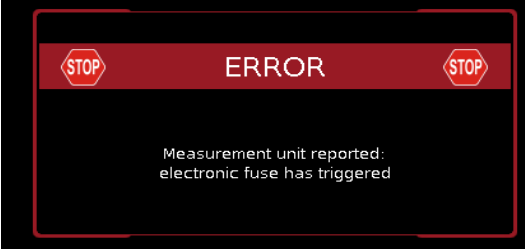

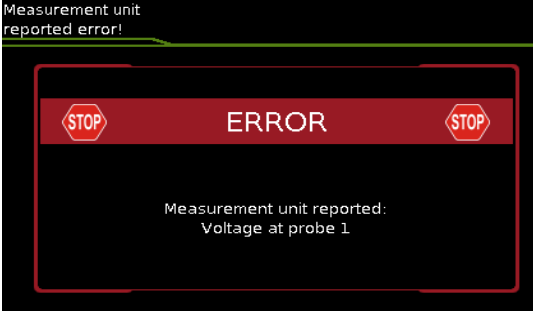

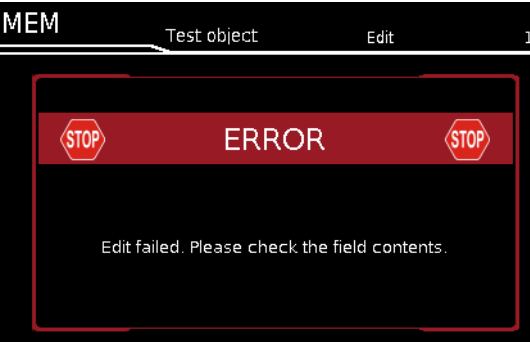
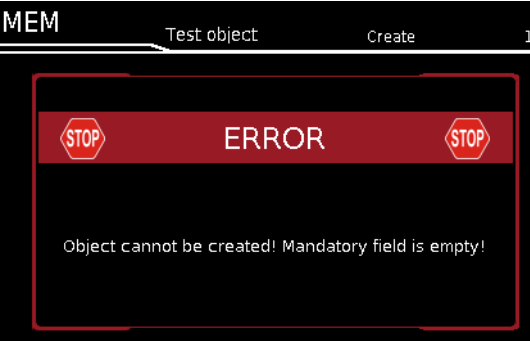
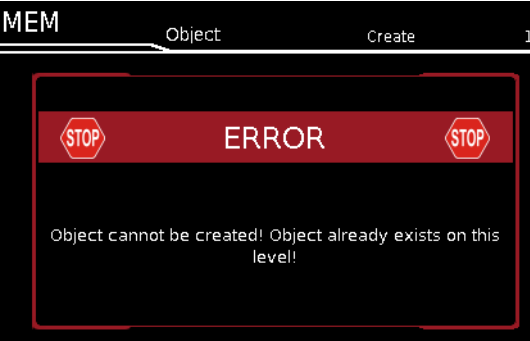
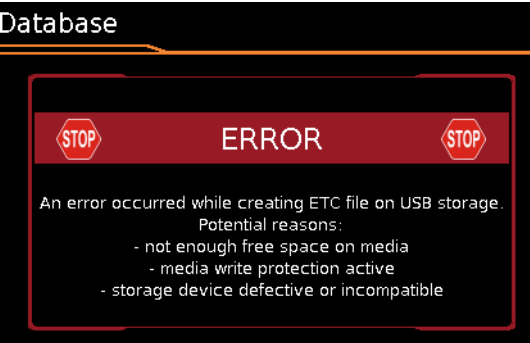

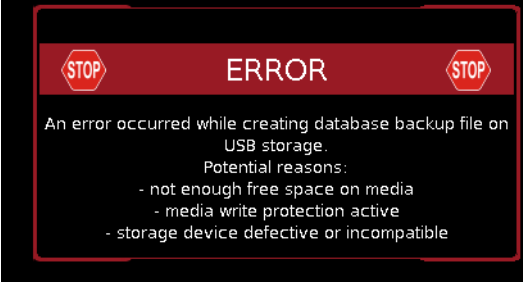
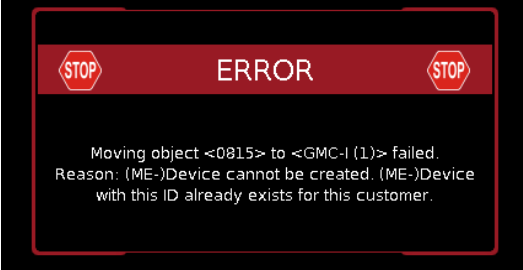
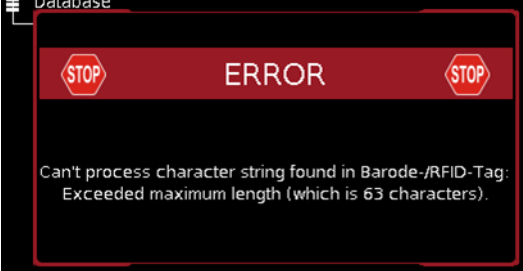
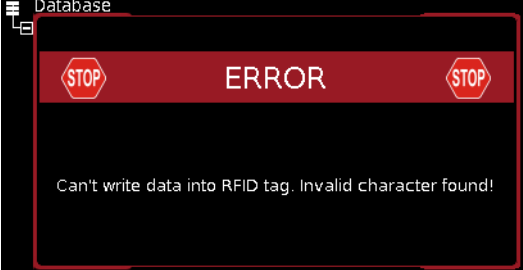
Error Messages	Possible Causes	Corrective Measures
<b>General Application Errors</b>		
<p>Testing persons management</p> 	<ul style="list-style-type: none"> <li>- The inspector to be deleted is currently selected and thus cannot be deleted!</li> </ul>	<ul style="list-style-type: none"> <li>⇒ Activate a different inspector before deleting.</li> </ul>
<p>Measurement unit reported error!</p> 	<ul style="list-style-type: none"> <li>- The 25 A measurements takes too long.</li> <li>or</li> <li>- The 25 A measurement has been executed too often (without pauses).</li> </ul>	<ul style="list-style-type: none"> <li>⇒ Wait until the test instrument has cooled down and then restart the measurement.</li> </ul>
<p>Measurement unit reported error!</p> 	<ul style="list-style-type: none"> <li>- Overvoltage at test probe 1 or the applied part sockets (only with feature J01)</li> </ul>	<ul style="list-style-type: none"> <li>⇒ If this problem occurs during a <b>leakage current measurement</b>, be sure to check the DUT for insulation faults between housing and voltage conducting parts!</li> <li>⇒ If this problem occurs during a <b>protective conductor resistance measurement</b>, check the test setup. No voltage conducting parts may be contacted with test probe P1 during this measurement.</li> <li>⇒ If this error occurs frequently despite correct (voltage-free) test setup, please contact our service department.</li> <li>⇒ Regardless of the utilized measuring function, the possibility cannot be ruled out that the <b>fuse link</b> for the probe socket (measurement with test Pro P1) or one of the fuse links for the applied part sockets (only with feature J01) has blown. Check and replace fuses if necessary.</li> </ul>

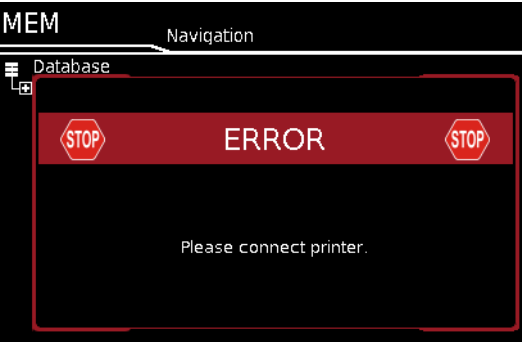
Error Messages	Possible Causes	Corrective Measures
	<ul style="list-style-type: none"> <li>- Excessive (touch) voltage at test probe P1</li> <li>- Test probe P1 was contacted although this is NOT specified for the selected measurement type.</li> </ul>	<ul style="list-style-type: none"> <li>⇒ Determine whether or not use of test probe P1 is permissible in the currently selected measurement type (if applicable on the basis of the illustration in the help image). If the test probe was contacted erroneously, make sure it's disconnected from the measuring circuit before restarting the measurement.</li> </ul> <p>Otherwise:</p> <ul style="list-style-type: none"> <li>⇒ If this problem occurs during a <b>leakage current measurement</b>, be sure to check the DUT for insulation faults between housing and voltage conducting parts!</li> <li>⇒ If this problem occurs during a <b>protective conductor resistance measurement</b>, check the test setup. No voltage conducting parts may be contacted with test probe P1 during this measurement.</li> <li>⇒ If this error occurs frequently despite correct (voltage-free) test setup, please contact our service department.</li> <li>⇒ Regardless of the utilized measuring function, the possibility cannot be ruled out that the <b>fuse link</b> for the probe socket (measurement with test Pro P1) or one of the fuse links for the applied part sockets (only with feature J01) has blown. Check and replace fuses if necessary.</li> </ul>

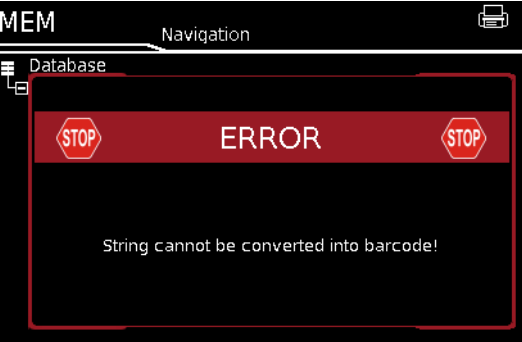
Error Messages	Possible Causes	Corrective Measures
<b>Database Processing Error</b>		
 <p>MEM Test object Edit 1</p> <p>ERROR</p> <p>Edit failed. Please check the field contents.</p>	<ul style="list-style-type: none"> <li>One of the fields was filled in with invalid content while processing an existing database object.</li> </ul>	<ul style="list-style-type: none"> <li>Please be certain to complete all mandatory fields (identified in red).</li> <li>If necessary, check your entries to the fields for invalid special characters.</li> </ul>
 <p>MEM Test object Create 1</p> <p>ERROR</p> <p>Object cannot be created! Mandatory field is empty!</p>	<ul style="list-style-type: none"> <li>The ID field was not filled in while creating a new device.</li> </ul>	<ul style="list-style-type: none"> <li>Fill in the ID field.</li> </ul>
 <p>MEM Object Create 1</p> <p>ERROR</p> <p>Object cannot be created! Object already exists on this level!</p>	<ul style="list-style-type: none"> <li>There's already an object with the same ID under the "Customer" database object.</li> </ul>	<ul style="list-style-type: none"> <li>An incorrect barcode has been selected.</li> <li>Assign another ID.</li> </ul>
 <p>Database</p> <p>ERROR</p> <p>An error occurred while creating ETC file on USB storage. Potential reasons: - not enough free space on media - media write protection active - storage device defective or incompatible</p>	<p><b>Error while writing the "secu" file to the USB flash drive</b></p> <p>There's not (no longer) enough available memory space on the storage medium.</p> <ul style="list-style-type: none"> <li>In particular in the case of FAT16 formatted USB flash drives: too many files on the USB flash drive</li> <li>Power consumption of the utilized USB flash drive exceeds 500 mA.</li> <li>The USB flash drive has been disconnected during data import.</li> <li>The USB flash drive is defective or incompatible with the test instrument.</li> </ul>	<ul style="list-style-type: none"> <li>Make sure that at least 100 MB is available on the USB flash drive and delete any data files which are no longer required.</li> <li>If the problem persists, save the data from the USB flash drive to another storage device and reformat the USB flash drive (FAT32).</li> <li>Only use USB flash drives with power consumption of less than 500 mA in combination with the test instrument.</li> <li>Make sure that the USB flash drive isn't disconnected or moved until the entire data export process has been completed.</li> <li>If none of these measures results in improvement, replace the USB flash drive. A list of tested USB flash drives is included in section 14.3.</li> </ul>

Error Messages	Possible Causes	Corrective Measures
<p><b>Database</b></p> 	<p><b>Error while writing the data backup file to the USB flash drive</b></p> <p>There's not (no longer) enough available memory space on the storage medium.</p> <ul style="list-style-type: none"> <li>- In particular in the case of FAT16 formatted USB flash drives: too many files on the USB flash drive</li> <li>- Power consumption of the utilized USB flash drive exceeds 500 mA.</li> <li>- The USB flash drive was disconnected during data import.</li> <li>- The USB flash drive is defective or incompatible with the test instrument.</li> </ul>	<ul style="list-style-type: none"> <li>⇒ Make sure that at least 100 MB is available on the USB flash drive and delete any data files which are no longer required.</li> <li>⇒ If the problem persists, save the data from the USB flash drive to another storage device and reformat the USB flash drive (FAT32).</li> <li>⇒ Only use USB flash drives with power consumption of less than 500 mA in combination with the test instrument.</li> <li>⇒ Make sure that the USB flash drive isn't disconnected or moved until the entire data backup process has been completed.</li> <li>⇒ If none of these measures results in improvement, replace the USB flash drive. A list of tested USB flash drives is included in section 14.3.</li> </ul>
<p><b>Move object</b></p> 	<p><b>Moving of an object has failed</b></p> <p>Moving a test object would lead to an ID conflict. The ID already exists for this customer.</p>	<ul style="list-style-type: none"> <li>⇒ Delete the object with duplicate ID.</li> <li>⇒ Select another customer as a relocation target.</li> </ul>
<p><b>Errors During Operation with Barcode or RFID Scanner</b></p>		
<p>Barcode/RFID Processing-Error</p> 	<ul style="list-style-type: none"> <li>- The scanned barcode is too long.</li> </ul>	
<p>MEM Navigation</p> 	<ul style="list-style-type: none"> <li>- While writing an RFID tag an attempt was made to write an ID to the tag with vowel mutations such as ä, ü or ö, or with special characters.</li> </ul>	<ul style="list-style-type: none"> <li>⇒ Change vowel mutations such as ä to ae.</li> <li>⇒ Avoid the use of special characters in the ID.</li> </ul>

Error Messages	Possible Causes	Corrective Measures
<b>Printer Connection Error</b>		
	<ul style="list-style-type: none"> <li>- The printer isn't connected.</li> <li>- An incompatible printer has been connected.</li> </ul>	<ul style="list-style-type: none"> <li>⇒ Connect the printer to the USB port before pressing the <b>PRINT</b> key.</li> <li>⇒ Make sure that the utilized printer is listed in section 14.1, "List of Suitable Printers with USB Port".</li> </ul>
	<ul style="list-style-type: none"> <li>- No recording chart in the thermal printer.</li> <li>- The printer is defective.</li> </ul>	<ul style="list-style-type: none"> <li>⇒ Insert a new recording chart.</li> </ul>
	<ul style="list-style-type: none"> <li>- The device ID to be printed as a barcode contains an inadmissible character, for example vowel mutation or special character, or it fails to conform to the conventions which apply to the selected barcode encryption type (e.g. EAN 13: only numeric characters, overall length 13 characters, last character as check digit only).</li> </ul>	<ul style="list-style-type: none"> <li>⇒ Select other barcode encryption (SETUP =&gt; Printer =&gt; Z721E =&gt; Printer Settings =&gt; Encryption)</li> <li>⇒ Change vowel mutations such as ä to ae.</li> <li>⇒ Avoid the use of special characters in the ID.</li> <li>⇒ Adjust the ID to the specified length for the selected type of barcode encryption.</li> </ul>
	<ul style="list-style-type: none"> <li>- A 3.5 or 6 mm tape cartridge has been inserted into the printer.</li> <li>- These tape sizes are inappropriate for 2D code printing.</li> </ul>	<ul style="list-style-type: none"> <li>⇒ Insert a cartridge with a tape width of 9 mm (or preferably 12 mm or more) and repeat printing.</li> <li>or</li> <li>⇒ Change to CODE128, CODE39 or EAN13 in SETUP.</li> </ul>
	<ul style="list-style-type: none"> <li>- A 9 mm tape cartridge has been inserted into the printer – this tape size is inappropriate for QR code label printing.</li> </ul>	<ul style="list-style-type: none"> <li>⇒ Insert a cartridge with a tape width of 12 mm and repeat printing.</li> <li>or</li> <li>⇒ Change to another output format in SETUP (MicroQR code, DataMatrix, Aztec, Code128, Code39 or EAN13).</li> </ul>

Error Messages	Possible Causes	Corrective Measures
<p data-bbox="151 129 240 165">Printer</p> 	<ul style="list-style-type: none"> <li data-bbox="699 120 1094 174">– The ID is too long to be printed as a Micro QR code.</li> </ul>	<ul style="list-style-type: none"> <li data-bbox="1114 120 1511 228">⇒ Shorten the ID or change to another output format in SETUP (QR Code, DataMatrix, Aztec, Code128, Code39, EAN13).</li> </ul>

## 11.2 List of Possible DUT Connections Depending on Measurement Type

Measurement Type	Suitable for DUT Connection via
<b>RPE</b>	
PE(TS) - P1 passive	Test socket, EL1 test socket, VL2E, AT3-IIIIE, AT3-IIS, AT3-IIS32, AT16DI/AT32DI
PE(TS) - P1 active	Test socket (for PRCDs)
PE(mains) - P1	Permanent connection
PE(mains) - P1 clamp	Permanent connection
P1 - P2	Permanent connection
<b>RINS</b>	
LN(TS) - PE(TS)	Test socket, EL1, VL2E, AT3-IIIIE, AT3-IIS, AT3-IIS32, AT16DI/AT32DI, CEE adapter
LN(TS) - P1	Test socket, VL2E, AT3-IIIIE, AT3-IIS, AT3-IIS32, AT16DI/AT32DI
P1 - P2	No connection (PC3)
PE(mains) - P1	Permanent connection
PE(TS) - P1	Test socket
LN(TS) - P1//PE(TS)	Test socket, VL2E, AT3-IIIIE, AT3-IIS, AT3-IIS32, AT16DI/AT32DI
LN(TS) - APP	Test socket and terminals for applied parts
PE(mains) - APP	Permanent connection and terminals for applied parts
PE(TS) - APP	Test socket and terminals for applied parts
P1//PE(TS) - APP	Test probe P1 / test socket and terminals for applied parts
P2 - APP	Test probe P2 and terminals for applied parts
<b>IPE</b>	
Direct	Test socket, AT16DI/AT32DI (direct or diff.)
Differential	Test socket
Alternative	Test socket, VL2E, AT3-IIIIE, AT3-IIS, AT3-IIS32, AT16DI/AT32DI
AT3 adapter	AT3-IIIIE, AT3-IIS, AT3-IIS32
Clamp	Permanent connection
<b>IT</b>	
Direct	Test socket, AT3-IIIIE, AT3-IIS, AT3-IIS32, AT16DI/AT32DI
Differential	Test socket
Alternative (P1)	Test socket, AT3-IIIIE, AT3-IIS, AT3-IIS32, AT16DI/AT32DI, VL2E
Perm. conn.	Permanent connection
Alternative (P1–P2)	No connection (PC3)
<b>IE</b>	
Direct	Test socket, AT16DI/AT32DI (only diff. is sensible)
Differential	Test socket
Alternative	Test socket, AT16DI/AT32DI
AT3 adapter	AT3-IIIIE, AT3-IIS, AT3-IIS32
Clamp	Permanent connection
<b>IA</b>	
Direct (P1)	Test socket
Direct APP	Test socket and terminals for applied parts
Alternative P1	Test socket
Alternative APP	Test socket and terminals for applied parts
Perm. conn. P1	Permanent connection
Perm. conn. APP	Permanent connection and terminals for applied parts
APP - P2	Test probe P2 and terminals for applied parts
<b>IP</b>	
Direct (P1)	Test socket
Perm. conn. (P1)	Permanent connection
Direct APP	Test socket and terminals for applied parts
Perm. conn. APP	Permanent connection and terminals for applied parts
<b>IPA</b>	
Direct APP	Test socket and terminals for applied parts
Perm. conn. APP	Permanent connection and terminals for applied parts

Measurement Type	Suitable for DUT Connection via
<b>U probe</b>	
PE - P1	Permanent connection
PE - P1 (with mains)	Test socket
<b>U meas.</b>	
V - COM	Permanent connection
V - COM (with mains)	Test socket
<b>tA</b>	
Mains to test socket	Test socket
<b>P</b>	
Function test	Test socket, AT3-IIIIE, AT3-IIS, AT3-IIS32, AT16DI/AT32DI, CEE adapter
<b>EL1</b>	
EL1 adapter	EL1 and test socket
AT3-IIIIE adapter	AT3-IIIIE
VL2E adapter	VL2E
<b>Temperature</b>	
V-COM PT100(0)	Permanent connection
<b>Current (via clamp)</b>	
V-COM	Permanent connection
V-COM (with mains)	Test socket
<b>PRCD time to trip</b>	
—	Test socket





## 12 Characteristic Values

Function	Measured Quantity	Display Range/ Nominal Range of Use	Resolution	Nominal Voltage $U_N$	Open-Circuit Voltage $U_0$	Nominal Current $I_N$	Short-Circuit Current $I_K$	Internal Resistance $R_I$	Reference Resistance $R_{REF}$	Measuring Uncertainty	Intrinsic Uncertainty	Overload Capacity		
												Value	Time	
Tests, 62638 (DIN VDE 071-0702) / IEC 62353 (VDE 0751)	Protective conductor resistance <b>RPE</b>	1 ... 999 m $\Omega$	1 m $\Omega$	—	< 24 V AC or DC	—	> 200 mA AC / DC > 10 A AC <sub>5</sub>	—	—	$\pm(15\% \text{ rdg.} + 10 \text{ d})$ > 10 d > 10.0 $\Omega$ : $\pm(10\% \text{ rdg.} + 10 \text{ d})$	$\pm(10\% \text{ rdg.} + 10 \text{ d})$ > 10 d	264 V 250 mA	Cont.	
		1.00 ... 9.99 $\Omega$	10 m $\Omega$									16 A AC <sub>5</sub>		
		10.0 ... 27.0 $\Omega$	100 m $\Omega$									> 42 A AC <sub>11</sub>	15 s	
	Insulation resistance <sup>9</sup> <b>RINS</b>	10 ... 999 k $\Omega$	1 k $\Omega$	50 ... 500 V DC	1.0 • $U_N$ ... 1.5 • $U_N$	> 1 mA	< 2 mA	—	—	$\pm(5\% \text{ rdg.} + 4 \text{ d})$ > 10 d $\geq 20 \text{ M}\Omega$ : $\pm(10\% \text{ rdg.} + 8 \text{ d})$	$\pm(2.5\% \text{ rdg.} + 2 \text{ d})$ > 10 d $\geq 20 \text{ M}\Omega$ : $\pm(5\% \text{ rdg.} + 4 \text{ d})$	264 V	Cont.	
		1.00 ... 9.99 M $\Omega$	10 k $\Omega$											
		10.0 ... 99.9 M $\Omega$	100 k $\Omega$											
	Leakage current, alternative measurement <sup>2</sup> <b>IPE, IT, IE, IA</b>	0 ... 99 $\mu$ A	1 $\mu$ A	—	50 ... 250 V~ –20/+10%	—	< 1.5 mA	> 150 k $\Omega$	1 k $\Omega$ $\pm 10 \Omega$	$\pm(5\% \text{ rdg.} + 4 \text{ d})$ > 10 d > 15 mA: $\pm(10\% \text{ rdg.} + 8 \text{ d})$	$\pm(2\% \text{ rdg.} + 2 \text{ d})$ > 10 d > 15 mA: $\pm(5\% \text{ rdg.} + 4 \text{ d})$	264 V	Cont.	
		100 ... 999 $\mu$ A	1 $\mu$ A											
		1.00 ... 9.99 mA	10 $\mu$ A											
	Leakage current, direct measurement <sup>3</sup> <b>IPE, IT, IE, IA, IP, IPA</b>	Only IP, IPA: 0.0 ... 99.9 $\mu$ A	100 nA	—	—	—	—	1 k $\Omega$ $\pm 10 \Omega$	1 k $\Omega$	$\pm(5\% \text{ rdg.} + 10 \text{ d})$ > 10 d	$\pm(2.5\% \text{ rdg.} + 5 \text{ d})$ > 10 d	264 V	Cont.	
		0 ... 99 $\mu$ A	1 $\mu$ A											
		100 ... 999 $\mu$ A	1 $\mu$ A											
		1.00 ... 9.99 mA	10 $\mu$ A											
	Leakage current, differential current measurement <sup>4</sup> <b>IPE, IT, IE</b>	0 ... 99 $\mu$ A	1 $\mu$ A	—	—	—	—	—	—	$\pm(5\% \text{ rdg.} + 10 \text{ d})$ > 10 d $\pm(5\% \text{ rdg.} + 4 \text{ d})$	$\pm(2.5\% \text{ rdg.} + 2 \text{ d})$ > 10 d	264 V	Cont.	
		100 ... 999 $\mu$ A	1 $\mu$ A											
		1.00 ... 9.99 mA	10 $\mu$ A											
		10.0 ... 30.0 mA	100 $\mu$ A											
	Function test at the test socket	Line voltage $U_{L-N}$ <sup>10</sup>	100.0 ... 240.0 V~	0.1 V	—	—	—	—	—	—	—	$\pm(2\% \text{ rdg.} + 2 \text{ d})$	264 V	Cont.
Load current $I_L$		0 ... 16.00 A <sub>RMS</sub>	10 mA	—	—	—	—	—	—	—	$\pm(2\% \text{ rdg.} + 2 \text{ d})$	16 A	Cont.	
Active power P		0 ... 3700 W	1 W	—	—	—	—	—	—	—	$\pm(5\% \text{ rdg.} + 10 \text{ d})$ > 20 d	264 V 20 A	Cont. 10 min.	
Apparent power S		0 ... 4000 VA	1 VA	Calculated value, $U_{L-N} \cdot I_V$								$\pm(5\% \text{ rdg.} + 10 \text{ d})$ > 20 d	264 V	Cont.
Power factor PF with sinusoidal waveform: $\cos\phi$		0.00 ... 1.00	0.01	Calculated value, P / S, display > 10 W								$\pm(10\% \text{ rdg.} + 5 \text{ d})$	264 V	Cont.
Line frequency f		0 ... 420.0 Hz	0.1 Hz	—	—	—	—	—	—	—	—	$\pm(2\% \text{ rdg.} + 2 \text{ d})$	264 V	Cont.
$t_{PRCD}$	Time to Trip	0.1 ... 999 ms	0.1 ms	—	—	30 mA	—	—	—	$\pm 5 \text{ ms}$	—	264 V	Cont.	
Voltage measurement	Probe voltage (probe P1 to PE) $\Rightarrow$ , $\sim$ and $\Rightarrow$	0.0 ... 99.9 V 100 ... 264 V	100 mV 1 V	—	—	—	—	3 M $\Omega$ 1 M $\Omega$	—	—	$\pm(2\% \text{ rdg.} + 2 \text{ d})$ $\pm(2\% \text{ rdg.} + 5 \text{ d})$ $\pm(5\% \text{ rdg.} + 5 \text{ d})$ > 10 kHz ... 20 kHz	264 V 300 V $\Rightarrow$ , $\sim$ and $\Rightarrow$	Cont.	
	Measuring voltage (V-COM sockets <sup>6</sup> ) $\Rightarrow$ , $\sim$ and $\Rightarrow$	0.0 ... 99.9 V 100 ... 300 V												
$I_{Leakage}$	Leakage current via AT3-III adapter Z745S <sup>6,8</sup>	0.00 ... 0.99 mA~	0.01 mA	—	—	—	—	—	—	—	$\pm(2\% \text{ rdg.} + 2 \text{ d})$ > 10 d without adapter	253 V	Cont.	
		1.0 ... 9.9 mA~	0.1 mA											
		10 ... 20 mA~	1 mA											
Temp	Temperature with Pt100 sensor	–200.0 ... +850.0 °C	0.1 °C	—	< 20 V–	—	1.1 mA	—	—	—	$\pm(2\% \text{ rdg.} + 1 \text{ }^\circ\text{C})$	10 V	Cont.	
	Temperature with Pt1000 sensor	–150.0 ... +850.0 °C												

Function	Measured Quantity	Display Range/ Nominal Range of Use	Resolution	Nominal Voltage $U_N$	Open- Circuit Voltage $U_0$	Nomi- nal Current $I_N$	Short- Circuit Current $I_K$	Internal Resis- tance $R_I$	Refer- ence Resis- tance $R_{REF}$	Measuring Uncertainty	Intrinsic Uncertainty	Overload Capacity	
												Value	Time
I <sub>Clamp</sub>	Current via current clamp sensor [1 mV : 1 mA] (V-COM sockets <sup>6,7</sup> )	1 ... 99 mA ~	1 mA (1 mV)	—	—	—	—	—	—	—	±(2% rdg.+2 d) > 10 d 20 Hz ... 20 kHz without clamp	253 V	Cont.
		0.1 ... 0.99 A ~	0.01 A (10 mV)										
		1.0 ... 9.9 A ~	0.1 A (100 mV)										
		10 ... 300 A ~	1 A (1 V)										
	Current via current clamp sensor [10 mV : 1 mA] (V-COM sockets <sup>6,7</sup> )	0.1 ... 9.9 mA ~	0.1 mA (1 mV)	—	—	—	—	—	—	—			
		10 ... 99 mA ~	1 mA (10 mV)										
		0.10 ... 0.99 A ~	0.01 A (100 mV)										
		1.0 ... 30.0 A ~	0.1 A (1 V)										
	Current via current clamp sensor [100 mV : 1 mA] (V-COM sockets <sup>6,7</sup> )	0.01 ... 0.99 mA ~	0.01 mA (1 mV)	—	—	—	—	—	—	—			
		1.0 ... 9.9 mA ~	0.1 mA (10 mV)										
		10 ... 99 mA ~	1 mA (100 mV)										
		0.10 ... 3.00 A ~	0.01 A (1 V)										
	Current via current clamp sensor [1000 mV : 1 mA] (V-COM sockets <sup>6,7</sup> )	1 ... 99 µA ~	1 µA (1 mV)	—	—	—	—	—	—	—			
		0.10 ... 0.99 mA ~	0.01 mA (10 mV)										
		1.0 ... 9.9 mA ~	0.1 mA (100 mV)										
		10 ... 300 mA ~	1 mA (1 V)										

<sup>2</sup> Known as equivalent leakage current or equivalent patient leakage current from previous standards

<sup>3</sup> Protective conductor current, touch current, device leakage current, patient leakage current

<sup>4</sup> Protective conductor current, touch current, device leakage current

<sup>5</sup> Only with feature F01

<sup>6</sup> Only with feature I01

<sup>7</sup> Measurement types IPE\_clamp and IG\_clamp

<sup>8</sup> Measurement type IPE\_AT3 adapter and IG\_AT3 adapter

<sup>9</sup> The upper range limit depends on the selected test voltage.

<sup>10</sup> Voltage at the test socket may be lower than measured line voltage due to components which limit inrush current.

<sup>11</sup> Only with feature G02

**Key:** rdg. = reading (measured value), d = digit(s)

### Testing Times, Automatic Sequence

Testing times ("measurement duration" parameter) can be set separately for each rotary switch position during configuration of the sequence parameters. Testing times are neither tested nor calibrated.

### Emergency Shutdown During Leakage Current Measurement

As of 10 mA of differential current (can also be set to 30 mA), automatic shutdown ensues within 500 ms. This shutdown does not take place during leakage current measurement with clamp meter or adapter.

### Influencing Quantities and Influence Error

ID	Influencing Quantity	RPE	RINS	IPE, It, IE, IA Alternative Leakage Current Measurement	IPE, It, IE, IA, Ip, IPA Direct Leakage Current Measurement	IPE, It, IE Differential Leakage Current Measurement
A	Intrinsic Uncertainty	±(10% rdg. + 10 d) > 10 d	±(2.5% rdg. + 2 d) > 10 d  ≥ 20 MΩ: ±(5% rdg. + 4 d)	±(2% rdg. + 2 d) > 10 d  > 15 mA: ±(5% rdg. + 4 d)	±(2.5% rdg. + 2 d) > 10 d	±(2.5% rdg. + 2 d) > 10 d
E1	Reference position ±90°	0%	0%	0%	0%	0%
E2	Supply voltage	2.5%	2.5%	2.5%	2.5%	2.5%
E3	Temperature 0 °C ... +40 °C	2.5%	2.5%	2.5%	2.5%	2.5%
E9	Mains harmonics				1%	1%
E11	Low frequency magnetic fields	2.5%	2.5%	2.5%	2.5%	2.5%
I12	Load current					2.5%

## Reference Ranges

Line voltage	230 V AC $\pm 0.2\%$
Line frequency	50 Hz $\pm 2$ Hz
Waveform	
Sine (deviation between effective and rectified value < 0.5%)	
Ambient temperature	+23 °C $\pm 2$ K
Relative humidity	40 ... 60%
Load resistance	Linear

## Nominal Ranges of Use

Nominal line voltage	100 V ... 240 V AC
Nominal line frequency	50 Hz ... 400 Hz
Line voltage waveform	Sinusoidal
Temperature	0 °C ... + 40 °C

## Ambient Conditions

Storage temperature	- 20 °C ... + 60 °C
Relative humidity	Max. 75%, no condensation allowed
Elevation	Max. 2000 m
Place of use	Indoors, except within specified ambient conditions

In order to avoid deviation due to excessive temperature fluctuation, e.g. after transport in low outdoor temperatures and subsequent operation in a warm indoor environment, it's advisable to wait until the test instrument has acclimatized before starting any measurements.

If the test instrument is colder than the ambient air, condensation may occur at high humidity, i.e. condensate may accumulate on components. This could result in the occurrence of parasitic capacitances and resistances which, in turn, affect the measuring circuit and measuring accuracy.

## Power Supply

Supply network	TN, TT or IT
Line voltage	100 V ... 240 V AC
Line frequency	50 Hz ... 400 Hz
Power consumption	200 mA DUT: Approx. 32 VA 10 A DUT: Approx. 105 VA 25 A DUT: Approx. 280 VA

Mains to test socket (e.g. during function test) Continuous max. 3600 VA, power is conducted through the instrument only, switching capacity  $\leq 16$  A, ohmic load, the AT3-IIS32 (Z745X) adapter (for example) can be used for current > 16 A AC

## USB data port

Type	USB slave for PC connection
Type	2 ea. USB master, for data entry devices * with HID boot interface, for USB flash drive for data backup, for USB flash drive for saving reports as HTML files, for printers *

\* See section 14 for compatible devices

## Bluetooth® data interface 2.1 + EDR (feature M01)

## Electrical Safety

Protection class	I per IEC 61010-1/DIN EN 61010-1/VDE 0411-1
Nominal voltage	230 V
Test voltage	2.3 kV AC 50 Hz or 3.3 kV DC (mains circuit / test socket to mains PE terminal, USB, finger contact, probe(s), APP sockets, test socket)
Measuring category	250 V CAT II
Pollution degree	2
Safety shutdown	At DUT differential current of > 10 mA, shutdown time: < 500 ms, can also be set to > 30 mA with following probe current during: – Leakage current measurement: > 10 mA~/< 500 ms – Protective conductor resistance measurement: > 250 mA~/< 1 ms in case of continuous current I > 16.5 A
Fuse Links	Mains fuses: 2 ea. FF 500V/16A Special fuse: M 250V/250mA <b>Feature G01:</b> 10 A RPE test current: 1 ea. FF 500V/16A <b>Feature J01:</b> Applied parts: 2 ea. M 250V/250mA

## Electromagnetic Compatibility

Product standard	DIN EN 61326-1:2013 DIN EN 61326 -2-2: 2013
------------------	--

Interference Emission		Class
EN 55011		B
IEC 61000-3-2		B
IEC 61000-3-3		B
Interference Immunity	Test Value *	Evaluation Criterion
EN 61000-4-2	Contact/atmos. – 4 kV/8 kV	B
EN 61000-4-3	10 V/m (80 MHz ... 1 GHz)	A
EN 61000-4-4	Mains connection – 2 kV	B
EN 61000-4-5	Mains connection – 1 kV (LN), 2 kV (LPE)	B
EN 61000-4-6	Mains connection - 3 V	A
EN 61000-4-8	30 A/m	A
EN 61000-4-11	0%: 1 period 0%: 250/300 periods 40%: 10/12 periods 70%: 25/30 periods	B C C C

## Mechanical Design

Display	4.3" multi-display (9.7 x 5.5 cm), backlit, 480 x 272 pixels at 24-bit color depth (true color)
Dimensions	W x H x D: 295 x 145 x 150 mm Height with handle: 170 mm
Weight	Feature G00/G01: approx. 2.5 kg Feature G02: approx. 4 kg
Protection	Housing: IP 40, Test socket: IP 20 per DIN VDE 0470, part 1/EN 60529 Table Excerpt Regarding Significance of IP Codes

IP XY (1 <sup>st</sup> digit X)	Protection Against Foreign Object Ingress	IP XY (2 <sup>nd</sup> digit Y)	Protection Against Water Ingress
2	$\geq 12.5$ mm $\varnothing$	0	Not protected
4	$\geq 1.0$ mm $\varnothing$	0	Not protected

### SECULIFE ST BASE(25):

Housing with antimicrobial properties per JIS standard Z 2801:2000

## 13 Maintenance

### 13.1 Housing Maintenance

No special maintenance is required for the housing. Keep outside surfaces clean. Use a slightly dampened cloth for cleaning. Avoid the use of cleansers, abrasives and solvents.

### 13.2 Testing the Color Display and the Buzzer (self-test parameter)

The color display can be tested for failure of individual segments and loss of color components on page 3/3 of the setup menu in the SETUP switch position under the self-test parameter.

Beyond this, the buzzer can be tested for 3 different frequencies.

### 13.3 Software Update (system info parameter)

The current firmware or software version can be queried via the system info parameter (Setup 3/3).

The test instrument's firmware can be updated via the USB port with the help of a PC. Updating is only possible via the proprietary **Firmware Update Tool** application.

- ⊘ Before updating your test instrument's firmware, make sure that your PC software is compatible with the current firmware version.



#### Attention!

Before updating the firmware, be sure to save the structures you have created and your measuring data, because they might be deleted during the update process (see section 5.2.3, "Backing Up and Restoring Test Structures and Measurement Data").



#### Note

Adjustment data are not overwritten during updating, and thus recalibration is unnecessary.

As a registered user (if you've registered your test instrument), you're entitled to download the **Firmware Update Tool** and the current firmware version free of charge from the **myGMC** page at [www.gossenmetrawatt.com](http://www.gossenmetrawatt.com).

You'll also find operating instructions for the **Firmware Update Tool** here.



#### Attention!

The interface cable may not be disconnected while updating the firmware via the USB port.



#### Attention!

The test instrument may not be disconnected from supply power while updating the firmware via the USB port.

---

### 13.4 Backup Battery for Real-Time Clock

The backup battery (lithium cell) should be replaced no later than after 8 years. Replacement can only be executed by the service department.

If backup battery voltage is too low, the date and time assigned to the test data no longer correspond to the actual time of recording. This may also influence sorting in the report generating software.

The instrument's database itself isn't affected by a depleted backup battery.

### 13.5 Fuse Replacement

The fuses may only be replaced when the instrument is voltage-free, i.e. the instrument must be disconnected from mains supply power and may not be connected to a measuring circuit.

The fuse type must comply with the specifications in the technical data or the labeling on the instrument.

### 13.6 Recalibration

The measuring tasks performed with your instrument, and the stressing it's subjected to, influence aging of its components and may result in deviation from the specified levels of accuracy.

In the case of strict measuring accuracy requirements, as well as in the event of use at construction sites with frequent stress due to transport and considerable temperature fluctuation, we recommend a relatively short calibration interval of once per year. If your instrument is used primarily in the laboratory and indoors without considerable climatic or mechanical stressing, a calibration interval of once every 2 to 3 years is sufficient as a rule.

During recalibration \* at an accredited calibration laboratory (DIN EN ISO/IEC 17025), deviations from traceable standards demonstrated by your measuring instrument are documented. Ascertained deviations are used to correct display values during later use of the instrument.

We would be happy to perform DAkkS or factory calibration for you at our calibration laboratory. Further information is available on our website:

[www.gossenmetrawatt.com](http://www.gossenmetrawatt.com) (→ Company → Quality and Certificates → DAkkS-Calibration Center → Calibration Questions and Answers).

According to DIN VDE 0701-0702, only test instruments which are tested and calibrated at regular intervals may be used for testing.

Recalibration of your instrument at regular intervals is essential for the fulfillment of requirements according to quality management systems per DIN EN ISO 9001.

\* Examination of the specification, as well as adjustment, are not included in calibration. However, in the case of our own products, any required adjustment is performed and adherence to the specification is confirmed.

### 13.7 Technical Safety Inspections

Conduct technical safety inspections on your test instrument at regular intervals. We recommend the same interval for inspections as is also used for recalibration.

The SECUTEST... is designed as a totally insulated device in accordance with IEC 61010 and IEC 61557-16/VDE 0413-16. The protective conductor is used for measuring purposes only, and is thus not always accessible. The protective conductor at the test socket can be tested as follows:

- Connect the SECUTEST... to a multiple distributor.
- Conduct a touch current measurement for permanently connected DUTs (nothing may be connected to the test socket).
- Measure protective conductor resistance between the neighboring socket at the multiple distributor and the test socket.
- The measured value may not exceed 0.3  $\Omega$ .

For technical reasons, insulation resistance between LN and PE inside the SECUTEST... is roughly 3 M $\Omega$ . This must be taken into consideration during technical safety inspections or, instead of the insulation resistance measurement, the protective conductor current measurement must result in a value of less than 3.5 mA (or less than 7 mA if the equivalent leakage current method is used).

There are also 4 accessible conductive parts on the SECUTEST..., at which the touch current measurement must result in a value of less than 0.5 mA:

- Connector for service plug (jack socket)
- USB ports
- Metallized start key
- Protective conductor bar in the test socket



#### Note

In order to prevent damage to the SECUTEST... test instrument, we recommend avoiding the performance of measurements at the USB ports.

### 13.8 Returns and Environmentally Sound Disposal

The instrument is a category 9 product (monitoring and control instrument) in accordance with ElektroG (German electrical and electronic device law). This device is subject to the RoHS directive. We also make reference to the fact that in this regard, the current status can be found on the Internet at [www.gossenmetrawatt.com](http://www.gossenmetrawatt.com) by entering the search term WEEE.

We identify our electrical and electronic devices in accordance with WEEE 2012/19/EU and ElektroG using the symbol shown at the right per DIN EN 50419.



These devices may not be disposed of with the trash.

Please contact our service department regarding the return of old devices (see address in section 15).

## 14 Appendix

### 14.1 List of Suitable Printers with USB Port

The following devices have been tested for use with the test instrument. We are unable to offer any guarantees regarding use with other devices.

- **Z721S thermal printer**
- **Z721E barcode printer**  
Setup options in the SETUP switch position (Setup (2/3) > Printer > Z721E > Printer settings)  
**Encryption:** Code39, Code128, EAN13, Text, QR Code, Micro QR Code, DataMatrix, Aztec  
The respective paper size is selected automatically (6, 9, 12, 18, 24 or 36 mm).



#### Note

##### Label Tapes

When using the label printer together with the test instrument, only TZ(e) tapes are supported with widths of 6, 9, 12, 18, 24 and 36 mm.



#### Note

##### 2D Code Labels

When printing 2D code labels (QR Code, MicroQR Code, DataMatrix, Aztec), we recommend label cartridges with tape widths of 12 mm or more, and in any case at least 9 mm.



#### Note

##### Text Encryption

Read-out to the CP1252 character set is limited in the "Text" print-out mode – characters which cannot be displayed are replaced by an underline (\_).

## 14.2 List of Suitable Barcode Readers and RFID Scanners with USB Port

The following devices have been tested for use with the test instrument. We are unable to offer any guarantees regarding use with other devices.

- **Z751A barcode reader**
- **Z751E RFID scanner (programmer)**

## 14.3 Use of USB Storage Devices

USB flash drives must be directly connected to the test instrument for various device functions (see sections 3.8 and 5.2).

The connected USB storage medium must fulfill at least the following requirements in order to be used with your test instrument:

- The file system on the USB flash drive must be FAT formatted (FAT32). NTFS and exFAT file systems, for example, are not compatible.
- Maximum current consumption of the USB storage medium via the USB port may not exceed 500 mA.
- Do not use USB storage devices with encrypting functions.

Furthermore, make sure that the USB drive includes an LED display which indicates whether or not write operations have been completed.

### List of recommended (tested) USB flash drives:

- Philips USB flash drive Snow Edition USB 3.0 (tested size: 64 GB)
- Toshiba TransMemory-MX U361 USB 3.0 (tested size: 64 GB)
- Corsair Flash Voyager Vega USB 3.0 (tested size: 16 GB)
- SanDisk Cruzer Glide USB 2.0/3.0 (tested size: 64 GB)



## 14.4 Bluetooth Interface (SECUTEST PRO BT (comfort) or feature M01)

The **Bluetooth**® interface permits use of the push-print function (see section 10.10).

**Setup 3/3**

**Menu selection for operating parameters, page 3 of 3**

**Bluetooth:** Menus for using the **Bluetooth**®-interface

**Menu selection for **Bluetooth**® operating parameters**

**Status:** Switch **Bluetooth**® interface on/off

**Device pairings \*:** Search/pair BT devices, view/edit existing pairings

**Device name \*:** The name of the test instrument displayed above the interface can be changed.

**Visibility \*:** Specifies whether the test instrument can be found by other **Bluetooth**®-devices.

\* These submenus only appear if status is set to on.

**List of already paired devices**

Paired device found (white frame) > rename or delete

Paired device found (blue frame) > rename or delete

Not yet paired device found (blue frame) > entry of pairing PIN

Search for **Bluetooth**® devices in close proximity

### Important Notes

- **Status/visibility:** For reasons of safety, we recommend deactivating the **Bluetooth**® interface if it's not needed. The "not visible" setting cannot be used as a substitute for shutting down the **Bluetooth**® interface, because invisible **Bluetooth**® devices can also be found using the appropriate means.
- **Device pairings** which will no longer be required for a lengthy period of time should be deleted.

- The DUT's **device name** is set to SECULIFE as a standard feature. If you access one PC with several test instruments, the name should be at least supplemented, for example SECULIFE1, SECULIFE2 etc.

## 14.5 Remote Control Interface

The test instrument's measuring functions can be remote controlled via the USB interface with the help of **IZYTRONIQ**. In this case, measured values do not appear at the test instrument's display and are instead transmitted via the respective data interface.

## 14.6 Entry via External USB Keyboard

Instead of using the touchscreen keyboard, characters can be entered directly with a USB keyboard which is connected to the test instrument. The touchscreen keyboard which appears at the display must be exited to this end.

### Switching from On-screen to USB Keyboard Entry

- ⇨ Press the **Return** key or the 4 softkey within a popup.
- ⇨ Alternatively, the **ESC** key can be pressed in order to exit a popup, MEM database management or the touchscreen keyboard.

### Switching Back and Forth Between USB Keyboard and On-Screen Entry (applies to versions with and without touch control)

Press the **TAB** key in order to switch back and forth between the external USB keyboard and on-screen entry.

#### 14.6.1 Additional Key Functions (Feature KD01, "Z853S – SECUTEST DB COMFORT")

If feature KD01 has been enabled, which is available for a fee, the following additional entry options are available:

**Print Screen** → PRINT

**ESC** → ESC

**F1** → HELP

**F2** → MEM

**F5** → Softkey 1

**F6** → Softkey 2

**F7** → Softkey 3

**F8** → Softkey 4

**F9** → Softkey 5

**F3** → Search for ID in the database (only in MEM database management, at the primary level of auto measurement screens and in green measurement screens)

**F4** → Search for "Text" in the database (only in MEM database management, at the primary level of auto measurement screens and in green measurement screens)

#### Additional key functions within MEM database management

**Cursor** → Navigation within the tree

**Home** → Jump to database root node

**End** → Jump to end of tree

**Tab** → Change location/customer tree

**Insert** → Create a new object

**Delete** → Delete object

↵ (Enter) → For editable objects: edit object,  
for measurements: test list view

⇧+Insert → Move object within tree  
(simultaneously press the shift and insert keys)

In the event that several objects have been found as a result of the search:

⇒ ⇐ → Scroll through found objects  
(right and left scroll keys)

#### Additional Key Functions in the Test List View (when the test report is shown at the display):

⇑⇓ → scroll (up and down scroll keys)

⇒ ⇐ → Switch to detail view or back to list of tests steps (right and left scroll keys)

**Tab** → Select filter type for test steps  
(abridged / failed test steps only / all)

↵ (Enter) → Exit test list view

## 14.7 Classification of DUTs

### 14.7.1 Protection Classes

Devices which are assigned to the following protection classes are all equipped with basic insulation, which assures protection against electric shock in combination with various additional precautions.

#### Protection Class I Devices

Exposed, conductive parts are connected to the protective conductor so that they're not charged with voltage if the basic insulation should fail.

#### Protection Class II Devices

These devices are equipped with double insulation or reinforced insulation.

#### Protection Class III Devices and Devices with Internal Power Supply

These devices are supplied with safety extra-low voltage (SELV). Beyond this, no voltages are generated which exceed SELV. These devices may not be connected to the mains.

#### Devices with Internal Power Supply

Devices with internal power supply are tested in the same way as permanently connected protection class II or III devices.

### 14.7.2 Applied Parts (electrical medical devices)

#### Type B Applied Parts (body)

Devices of this type are suitable for both internal and external patient applications, except for use in direct proximity to the heart. These devices provide for adequate protection against shock especially as regards:

- Reliable leakage current
- Reliable protective conductor connection if utilized

The following protection classes are permissible:  
I, II, III or devices with internal electric power supply.

#### Type BF Applied Parts (body float)

Same as type B, but with type F insulated applied parts.

#### Type CF Applied Parts (cardiac float)

Devices of this type are suitable for use directly at the heart. The applied part may not be grounded.

The following protection classes are permissible:  
I, II or devices with internal electric power supply.



## 14.9 Index

### Numerics

2nd Test Probe .....	3, 26
2-Pole Measurement (P1-P2) .....	26

### A

Alternative Test Frequency .....	25
Applied Parts	
Selection .....	81
Auto Measuring Point .....	76

### B

Backup Battery .....	105
Barcode Reader	
List .....	107
Barcode Scanner	
Configuration .....	10
Connection .....	10
Barcodes	
Read-In .....	10

### C

Calibration Data .....	15
Classification .....	109
Classification Parameter .....	78
Connection	
Prompts .....	26
Test Probe P1 or P2 .....	13
Tests .....	26
Connections	
Overview .....	3
Continuous Measurement	
Icon .....	77

### D

Detail View .....	78
Detection of Probes / Measurement Cables .....	26
Devices with Internal Power Supply .....	109
Dual-Lead Measurement (P1-P2) .....	26
DUT Connection Detection .....	26

### E

End of Sequence .....	76
Enter, Select, Delete or Protect Inspector with Password .....	14
Equivalent Leakage Current	
Limit Values .....	53
Error Displays .....	89
Error Messages .....	90

### F

Firmware Update Tool .....	105
Fuse	
APPs .....	75
Probe P1 .....	75
Fuses	
Characteristic Values .....	104
Location .....	3
Replacement .....	7, 105

### I

Initial Window	
Style .....	76
Insulation Resistance .....	6
Limit Values .....	40
IT Systems .....	12

### K

Keyboard Layout .....	10, 21
-----------------------	--------

### L

Language .....	10
Language Selection .....	10, 15
Limit Value Mode .....	76
Limit Value Violation .....	87

### M

Mains Connection	
Errors .....	13
Plug .....	12

Maintenance .....	105
Measuring Sequence	
With Pre-Selection of the DUT .....	29
With Subsequent Entry of the DUT .....	29
Measuring Sequences	
Standard Selection .....	76
Measuring Uncertainty .....	76
Multi-Print .....	10

### O

Offset Values .....	33
On Test .....	26
Overview	
Controls .....	2
Included Features .....	4

### P

Patient Leakage Current	
Limit Values .....	61
Periodic Testing .....	6
PRCD .....	31, 70
PRCD Type .....	82
Protection Class Detection .....	26
Protection Class I Devices .....	109
Protection Class II Devices .....	109
Protection Class III Devices .....	109
Protective Conductor Resistance .....	6
Protective Extra-Low Voltage .....	109

### R

Real-Time Clock .....	105
Recalibration .....	105
Recalibration Date .....	15, 30
Reference Voltage L-PE .....	25
Reports .....	10
Residual Current Monitoring .....	25
Retrieve (last) Measured Values	
Single Measurements .....	29
Retrieving (last) Measured Values	
Database Function .....	24
Returns .....	106
RFID Scanner	
List .....	107
RFID Tags	
Read .....	10
Write .....	11
RoHS Directive .....	106
Routine Tests .....	6

### S

Safety Precautions .....	7
Scope of Delivery .....	4
Scope of Functions .....	4
SECUTEST CLIP .....	43, 52
Self-Test .....	105
Sequence Parameters .....	83
Short-Circuit Test .....	26
Software	
Update .....	105
Version .....	3, 14
Switching Loads – Maximum Starting Current .....	7
Switching Power Consumers – Procedure .....	7
Symbols	
Object Creation .....	22
on the Instrument .....	9
User Interface	
Database Management .....	21
Single Measurements .....	29
Test Sequence .....	77

### T

Table of Single Measurements .....	6
Technical Safety Inspections .....	106
Testing After Repairs .....	6
Touch Click .....	78

Touch Current .....	26
Touchscreen .....	21
Tree View .....	78
Type B Applied Parts .....	109
Type BF Applied Parts .....	109
Type CF Applied Parts .....	109
<b>U</b>	
USB Flash Drive	
Database Backup .....	18
ETC File Export .....	18
ETC File Import .....	18
Restoring a Database .....	18
Saving Reports .....	11
USB Keyboard .....	21
<b>V</b>	
Voltage Measuring Inputs .....	3
<b>W</b>	
WZ12C .....	33, 43, 52

## 15 Repair and Replacement Parts Service Calibration Center \* and Rental Instrument Service

If required please contact:

GMC-I Service GmbH  
**Service Center**  
Beuthener Str. 41  
D-90471 Nuremberg, Germany  
Phone: +49-911-817718-0  
Fax: +49-911-817718-253  
e-mail [service@gossenmetrawatt.com](mailto:service@gossenmetrawatt.com)  
[www.gmci-service.com](http://www.gmci-service.com)

This address is only valid in Germany.  
Please contact our representatives or subsidiaries for service in  
other countries.

\* DAkkS calibration laboratory for electrical quantities, registration no.  
D-K-15080-01-01, accredited per DIN EN ISO/IEC 17025  
Accredited quantities: direct voltage, direct current value, direct current  
resistance, alternating voltage, alternating current value, AC active power,  
AC apparent power, DC power, capacitance, frequency and temperature

### Competent Partner

GMC-I Messtechnik GmbH is certified per DIN EN ISO 9001.

Our DAkkS calibration laboratory is accredited by the Deutsche  
Akkreditierungsstelle GmbH (national accreditation body of the  
Federal Republic of Germany) under registration number D-K-  
15080-01-01 in accordance with DIN EN ISO/IEC 17025.

We offer a complete range of expertise in the field of metrology:  
from test reports and factory calibration certificates right on up to  
DAkkS calibration certificates. Our spectrum of offerings is  
rounded out with free test equipment management.

An on-site DAkkS calibration station is an integral part of our ser-  
vice department. If errors are discovered during calibration, our  
specialized personnel are capable of completing repairs using  
original replacement parts.

As a full service calibration laboratory, we can calibrate instru-  
ments from other manufacturers as well.

## 16 Product Support

If required please contact:

GMC-I Messtechnik GmbH  
**Product Support Hotline**  
Phone: +49-911-8602-0  
Fax: +49 911 8602-709  
e-mail [support@gossenmetrawatt.com](mailto:support@gossenmetrawatt.com)

---

Edited in Germany • Subject to change without notice • PDF version available on the Internet

 **GOSSEN METRAWATT**

GMC-I Messtechnik GmbH  
Südwestpark 15  
90449 Nürnberg • Germany

Phone: +49-911-8602-111  
Fax: +49 911 8602-777  
e-mail: [info@gossenmetrawatt.com](mailto:info@gossenmetrawatt.com)  
[www.gossenmetrawatt.com](http://www.gossenmetrawatt.com)